

(REVISED COURSE) QP Code : NP-17768

(2 Hours)

[Total Marks : 60

- N. B. : (1) Question no. I is compulsory.
 (2) Figures to right indicates marks.
 (3) Attempt any three questions from Q. no. 2 to Q. no. 6.
 (4) Use necessary data wherever required.

1. Attempts any five :- 15
- (a) Why the Newton's rings are circular and centre of interference pattern (reflected) is dark?
- (b) What is Rayleigh criteria of resolution? What is resolving power of diffraction grating?
- (c) An optical glass fibre of refractive index 1.50 is to be clad with another glass to ensure internal reflection that will contain light travelling within 5° of the fibre axis. What maximum index of refraction is allowed for the cladding?
- (d) What is acronym of 'LASER'? How are they different than X-rays?
- (e) An electron is bound in one dimensional potential well of width $2A^\circ$ that of infinite height. Find its energy value in the ground state.
- (f) Explain measurement of frequency of AC signal using CRO
- (g) What is the vortex state of a superconductor?
2. (a) With Newton's ring experiment explain how to determine the refractive index of Liquid. 8
 In Newton's ring experiment, the diameter of 15th dark ring was found to be 0.590 cm and that of 5th dark ring was 0.336 cm. If the radius of curvature of planoconvex lens is 100 cm, calculate the wavelength of light.
- (b) Differentiate between S.I. fibre and GRIN fibre. Derive the expression for N.A. for step Index fibre. 7
3. (a) What is holography? Explain its construction and reconstruction with neat diagram. 8
 (b) Obtain the conditions for maxima and minima due to interference in a wedge shaped film observed in reflected light. Two optically plane glass strips of length 10 cm are placed one over the other. A thin foil of thickness 0.01 mm in introduced between them at one end to form an air film. If the light used has wavelength 5900 \AA , find the separation between consecutive bright fringes. 7
4. (a) What is grating element? Derive condition for maximum diffraction at diffraction grating. 5
 (b) What is Heisenberg's uncertainty principle? Show that electron can not exist in nucleus. 5
 (c) What is superconductivity? Differentiate between Type-I and Type II superconductors. 5

Con. 9441-14.



[TURN OVER

5. (a) In plane transmission grating, the angle of diffraction for the second order principal maxima for the wavelength 5×10^{-5} cm is 30° . Calculate the no. of lines/cm. on diffraction grating. 5
- (b) Derive one dimensional time dependent schrodinger wave equation for matter wave. 5
- (c) With neat diagram explain construction and working of Scanning Electron Microscope. 5
6. (a) Calculate the velocity and De Broglie wavelength of an α -particle of energy 1 KeV. Given Mass of α -particle = 6.68×10^{-27} kg. 5
- (b) With neat diagram explain construction and working of CRT. 5
- (c) Explain the Physical Methods for synthesis of Nanoparticles. 5



Con. 9441-14.

(REVISED COURSE) QP Code : NP-17782

(3 Hours)

[Total Marks : 80

- N. B. :** (1) Question No. 1 is compulsory.
 (2) Attempt any **three** questions from remaining five questions.
 (3) **Figures to right** indicate full marks.
 (4) Assume suitable data if necessary, but justify the same

1. (A) What do you mean by algorithm? Which points you should consider while developing the algorithm. 4
1. (B) Determine the type of triangle, given its sides. (i.e. isosceles, scalene, equilateral). Is the above problem definition is complete? if not, make this problem definition complete. 4
1. (C) State any 2 library function in string.h along with its uses. 4
1. (D) What do you mean by auto and extern storage class. Explain with example. 4
1. (E) Explain switch control statement with the help of example. 4
2. (A) Write a program in C to delete all the occurrences of given number from an ARRAY. For example, suppose ARRAY A = { 2, 5, 3, 9, 2, 2, 3 } and given no is 2 then after deletion ARRAY should have A = { 5, 3, 9, 3 } 10
2. (B) Write a program to check whether the given number is palindrome or not. i.e if no is 12421 it is palindrome 10
3. (A) What do you mean by Recursion? write a program which will accept two numbers, n and r and calculate value of $nC_r = \frac{n!}{r!(n-r)!}$. Program should make use of recursion. 10
3. (B) Write a program to sort given nos in Ascending order. 10
4. (A) A Hospital needs to maintain details of patients. Details to be maintained are, First name, Middle name, Surname, Date of Birth, Disease. Write a C program which will print the list of all patients with given disease. 10
4. (B) write a program which will accept a 2 dimensional square matrix and find out transpose of it. Program should not make use of another matrix. 10
5. (A) Write a program to generate following patterns. 10

(i)

```

1
2 3
4 5 6
7 8 9 10

```

(ii)

```

      *
     * *
    * * *
   * * *
  * * *
 * * *

```



- 2
5. (B) Write a C program to multiply 2 matrices after checking compatibility. Your program should make use of function to accept element of matrix, display matrix, and multiply matrix
6. (A) Write a program to calculate summation of series.
 $1/2 - 3/4 + 5/6 - 7/8 + \dots$ upto n terms. 10
6. (B) What do you mean by FILE ? What are the different functions available to read data from file ? Specify the different modes in which file can be opened along with syntax. 10
-

FE-II

A.M.II

15.5.14

(REVISED COURSE) QP Code : NP-17762

(3 Hours)

[Total Marks : 80

- B. : (1) Question No.1 is compulsory.
 (2) Attempt any three question from remaining five questions.

(a) Evaluate $\int_0^1 \sqrt{\sqrt{x}-x} dx$ 3

(b) Solve $[D^4 - 4D^3 + 8D^2 - 8D + 4]y = 0$ 3

(c) Prove that $(1 + \Delta)(1 - \nabla) = 1$ 3

(d) Change to polar co-ordinate and evaluate $\int_0^a \int_0^{\sqrt{a^2-x^2}} (x^2+y^2) dy dx$ 3

(e) Solve $(x^2 - 4xy - 2y^2) dx + (y^2 - 4xy - 2x^2) dy = 0$ 4

(f) Evaluate $\int_0^a \int_0^{\sqrt{1+x^2}} \frac{1}{1+x^2+y^2} dy dx$ 4



2. (a) Solve $xy(1+xy^2) \frac{dy}{dx} = 1$ 6

(b) Change the order of integration and evaluate $\int_0^\infty \int_0^x x e^{-x^2/y} dy dx$ 6

(c) Evaluate $\int_0^{\pi/2} \frac{dx}{a^2 \sin^2 x + b^2 \cos^2 x}$ and show that 8

$$\int_0^{\pi/2} \frac{dx}{(a^2 \sin^2 x + b^2 \cos^2 x)^2} = \frac{\pi}{4ab} \left(\frac{1}{a^2} + \frac{1}{b^2} \right)$$

3. (a) Evaluate $\iiint x^2 yz dx dy dz$ throughout the volume bounded by $x=0, y=0, z=0, x+y+z=1$. 6

(b) Find the area bounded by parabola $y^2 = 4x$ and the line $y = 2x - 4$. 6

(c) Use the method of variation of parameter to solve 8

$$\frac{d^2y}{dx^2} + 5 \frac{dy}{dx} + 6y = e^{-2x} \sec^2 x (1 + 2 \tan x)$$

4. (a) Find the total length of the loop of the curve $9y^2 = (x + 7)(x + 4)^2$. 6
- (b) Solve $\frac{d^2y}{dx^2} + 2y = x^2e^{3x} + e^x - \cos 2x$ 6
- (c) Apply Runge-kutta method of fourth order to find an approximate value of y at $x = 0.2$ 8
if $\frac{dy}{dx} = x + y^2$ give that $y = 1$, when $x = 0$ in step of $h = 0.1$.
5. (a) Solve $y(x^2y + e^x) dx - e^x dy = 0$. 6
- (b) Using Taylor's series method solve $\frac{dy}{dx} = 1 - 2xy$ given that $y(0) = 0$ and hence find 6
 $y(0.2)$ and $y(0.4)$.
- (c) Compute the value of the definite integral $\int_{0.2}^{1.4} (\sin x - \log_e x + e^x) dx$, by 8
(i) Trapezoidal Rule
(ii) Simpson's one third Rule
(iii) Simpson's three-eighth Rule.
6. (a) The motion of a particle is given by $\frac{d^2x}{dt^2} = -k^2x - 2h\frac{dx}{dt}$, solve the equation when 6
 $h = 5, k = 4$ taking $x = 0, v = v_0$ at $t = 0$. Show that the time of maximum displacement is independent of the initial velocity.
- (b) Evaluate $\iint (x^2 + y^2) dx dy$ over the area of triangle whose vertices are $(0, 0), (1, 0),$ 6
 $(1, 2)$.
- (c) Find the volume bounded by $y^2 = x, x^2 = y$ and the planes $z = 0$ and $x + y + z = 1$. 8

QP Code : NP-17786

(Revised Course)
(2 Hours)

[Total Marks : 40

- N.B. :** (1) Question no.1 is compulsory.
(2) Attempt any **three** questions of the remaining **five** questions.
(3) Answers to all the sub questions should be attempted and grouped together.
(4) **Figures** to the right indicate **full marks**.

1. (a) Explain any 2 psychological barriers. 3
(b) Fill in the blanks (with the words given below the sentences) 3
(i) Every programming language and software has _____ limitations.
(ii) ABC of Communication refers to _____, _____ and _____.
(iii) Many ecologists are concerned that the "green house effect" is changing many of the earth's _____ weather patterns into _____ systems unable to be accurately forecast by those who study them.
- (Clarity, jargon, passive voice, predictable, uncanny, chaotic, growing, erratic, attitude, break, accuracy, brevity, its, their, implies, induces.)
- (c) What is 'You attitude'? 2
(d) Explain the difference between caution and warning, giving an example for each. 2
2. (a) Give an outline of the Communication cycle and explain the components giving an example. 4
(b) Give a diagrammatic representation of the parts of a letter in Complete Block Form. 3
(c) Change the following instructions to use the Udell overhead projector into a process description. 3

The projector bulb heats up during operation. Do not touch. Keep air vents uncovered to allow for proper cooling.

To operate the Udell, follow these eight simple steps :—

- (i) Place the projector on a level surface, approximately 6-10 feet from a projector screen or blank wall.
(ii) Plug the power supply cord into a 110V 60 Hz AC wall outlet.
(iii) Push the rocker to the "on" position.

Con. 9453-14.



[TURN OVER

- (iv) Place the material to be viewed squarely on the projector's stage.
- (v) Adjust the height of the projected image by lowering or raising the projector's lens head.
- (vi) Rotate the focus knob for clear viewing of the projected image.
- (vii) Push the rocker switch to the 'off' position when you are through viewing your material.
- (viii) Unplug the unit's power cord.

Following these eight simple steps will help you use the Udell overhead projector.

3. (a) How do you interpret the following non-verbal cues sent by others? Do they always mean the same to you? 4
- (i) Yawning
 - (ii) Drooping Shoulders
 - (iii) Raised eye- brows
 - (iv) Silent after a question
- (b) As the Head of the Production Unit of New Age Vision, Jaipur, you have received a complaint from the Graam Sevak of Ladanpur village-a remote hamlet in Rajasthan-who has complained about the unruly, rude, and offensive manner in which some of the crew members of your company conducted themselves during their stay in the village while shooting for a documentary entitled 'Vision Village: Vision India'. Draft an apology letter expressing your regret and assuring action from your side. 6
4. (a) How can one be an effective speaker? 4
- (b) Your college is organizing the National Sports meet in June 2014. You require a lot of sports gear for various sports & games. As the Sports Secretary of your college write a letter of enquiry to a sports dealer regarding your requirements. 6
5. (a) "Hearing is natural, listening needs effort." Explain the statement with reference to techniques to be an effective listener. 4
- (b) Give one word substitutes for the following :— (any two) 2
- (i) One who analyses elections, voting, votes etc.
 - (ii) Study of birds.
 - (iii) Something which happens once every two years.
- (c) Correct the errors in the following letter and rewrite in Semi block format. 4



BRONCO AIRLINES
711 Gamblers Boulevard
Denver, Colorado 41215
Tel. 1-800-cockpit

February 10, 20

Mrs. Vonnie Bishop
3315 Keats Road
Spokane, WA 98406-3452

Dear Mrs. Bishop

Sign up today for
Bronco's

Good news! Bronco Airlines will begin service to and from Spokane on March 1 Frequent
flyer program, your passport to a world of free or Discounted travel.

You'll like Bronco Airlines because at our low Fares, convenient air schedules and excellent
personnel service. When you're seated in our Business section. Your copy of "The Wall
Street Journal" will be waiting for you.

Take our Early Bird flight to Seattle for only \$49 or to Portland for only \$69. Save money
save the day-that's the Bronco Spirit!

See the enclosed Bronco world route map and the brochure describing our fully
automated Frequent Flyer program. Then call your Bronco agent to make your first
reservation and accumulate your first Bonus points!

Sincerely,

Will McGoof
Will McGoof



Con. 9453-14.

[TURN OVER



6. (a) Define the following :— (any two)
Proxemics, Computer, Radar, Welding

2

(b) State whether the following statements are true or false :—

2

- (i) Silence speaks louder than words.
- (ii) One should write to impress.
- (iii) Engineers do not require Communication Skills.
- (iv) Acting is a form of Communication.

(c) Read the following passage and answer the questions given below :—

If popularity is the benchmark of capability, the 'dirty' fuel is now measuring up to it. Diesel had been a loser for long, trying to catch up with gasoline in terms of efficiency and performance. It was much- maligned by rattling technology and noisy operations. Now after decades, diesel cars have taken over the Indian market leaving petrol- fired cars behind.

For the first half of 2010, the Indian auto market witnessed a spurt in the sales of diesel propelled cars. So much so in India's premium segment- from Maruti Swift to the BMW 7 Series category- 59% of the 6.88 lakh units sold in the first half of 2010 were diesel powered. The percentage is even higher than Europe, where the market is evenly divided between both the fuels.

Auto companies in India attribute this change to technology advancements that have given diesel higher fuel efficiency and better pick up. Historically the sales of diesel - driven cars had plummeted due to high maintenance costs and premium pricing.

The gradual change has now become a major determining factor for the success and failure of new cars. The verdict is clearly in favour of diesel- driven cars, Customers are pleasantly surprised by the clear advantage of instant acceleration and higher torques offered by modern diesel engines, even as petrol is trying to catch up on the technological changes.

For Indians with deep pockets, it is the luxury car segment running on diesel that is most popular. Consider this: Of the 446 cars in the BMW 7 series, Audi B and Mere 5 Class models, sold in the first six months of 2010, 79% had diesel engines. Indian customers prefer cheaper diesel models which provide better acceleration and return on investment. The times are not far away when diesel will be the strongest portfolio across all segments. The diesel strategy has paid Toyota rich dividends. In the premium sports utility vehicle(SUV) segment, its diesel Fortuner, launched last year, has ended the domination of competitive models like the erstwhile segment leaders, Honda's CRY and Mitsubishi Outlander that are only available in petrol versions.

The preference for diesel is particularly noticeable in premium cars, priced above Rs 4 lakh and luxury sedans and SUVs in the Rs 1 Crore bracket. The affinity for diesel also follows the introduction of the much acclaimed common rail injection (CRDi) technology that was first launched in 2002 by Hyundai in its Ascent sedan. Sharp-injector based fuel technology allowed diesel to burn much faster with learner operations, leading to higher fuel efficiency and faster accelerations.

Over the years, several modifications in diesel technology have been taken up by auto companies. Even entry-level cars made by Indian companies like Mahindra's Scorpio and Tata Motors' Indica now come loaded with modern diesel engines based on the CRDi technology, that was once the domain of high-priced cars.

Answer the following questions by choosing the right options.

- (1) The author in this passage attempts to establish which of the following? 1
- The diesel cars these days are not only attractive but also costly.
 - Modern day diesel cars are economic as well as attractive.
 - In future, diesel cars are likely to become a dominant force in the Indian market.
 - Indians are pleasantly surprised by the clear advantage of having a diesel car.
- (2) With which of the following is the author most likely to disagree? 1
- Though diesel cars are becoming attractive, they are not as efficient as petrol cars.
 - Indian customers prefer diesel models which provide better acceleration.
 - Now diesel cars are more popular than petrol cars in India.
 - The companies that produce only petrol versions are losing their domination in the market.
- (3) In the author's view, the preference for diesel cars in the Indian auto market is due to which of the following? 1
- Recession has made Indian customers wary of expensive petrol-driven car.
 - Technological advancements have helped diesel cars become more efficient and economical.
 - Diesel cars have rich dividends to offer to the customers.
 - Today, the number of diesel cars produced far exceeds the number of petrol cars produced.



- (4) The phrase 'Indians with deep pockets ...' suggest which of the following
- Indians who are rich
 - Indians who are more inclined towards buying petrol cars.
 - Indians who are more inclined towards buying diesel cars.
 - Indians who prefer utility to luxury while purchasing a car.
- (5) Give synonyms for
Spurt, acclaimed.
- (6) Give antonyms for
Acceleration, domination.



Con. 9453-14.

- N. B. :** (1) Question no. I is compulsory.
 (2) Figures to right indicates marks.
 (3) Attempt any three questions from Q. no. 2 to Q. no. 6.
 (4) Use necessary data wherever required.

1. Attempts any five :- 15
- Why the Newton's rings are circular and centre of interference pattern (reflected) is dark?
 - What is Rayleigh's criteria of resolution? What is resolving power of diffraction grating?
 - An optical glass fibre of refractive index 1.50 is to be clad with another glass to ensure internal reflection that will contain light travelling within 5° of the fibre axis. What maximum index of refraction is allowed for the cladding?
 - What is acronym of 'LASER'? How are they different than X-rays?
 - An electron is bound in one dimensional potential well of width $2A^\circ$ that of infinite height. Find its energy value in the ground state.
 - Explain measurement of frequency of AC signal using CRO
 - What is the vortex state of a superconductor?
2. (a) With Newton's ring experiment explain how to determine the refractive index of Liquid. 8
 In Newton's ring experiment, the diameter of 15th dark ring was found to be 0.590 cm and that of 5th dark ring was 0.336 cm. If the radius of curvature of planoconvex lens is 100 cm, calculate the wavelength of light.
- (b) Differentiate between S.I. fibre and GRIN fibre. Derive the expression for N.A. for step Index fibre. 7
3. (a) What is holography? Explain its construction and reconstruction with neat diagram. 8
 (b) Obtain the conditions for maxima and minima due to interference in a wedge shaped film observed in reflected light. Two optically plane glass strips of length 10 cm are placed one over the other. A thin foil of thickness 0.01 mm is introduced between them at one end to form an air film. If the light used has wavelength 5900 \AA , find the separation between consecutive bright fringes. 7
4. (a) What is grating element? Derive condition for maximum diffraction at diffraction grating. 5
 (b) What is Heisenberg's uncertainty principle? Show that electron can not exist in nucleus. 5
 (c) What is superconductivity? Differentiate between Type-I and Type II superconductors. 5



5. (a) In plane transmission grating, the angle of diffraction for the second order principal maxima for the wavelength 5×10^{-5} cm is 30° . Calculate the no. of lines/cm. on diffraction grating. 5
- (b) Derive one dimensional time dependent schrodinger wave equation for matter wave. 5
- (c) With neat diagram explain construction and working of Scanning Electron Microscope. 5
6. (a) Calculate the velocity and De Broglie wavelength of an α -particle of energy 1 KeV. Given Mass of α -particle $=6.68 \times 10^{-27}$ kg. 5
- (b) With neat diagram explain construction and working of CRT. 5
- (c) Explain the Physical Methods for synthesis of Nanoparticles. 5



Con. 9441-14.

Q2 Figure given below shows the pictorial view of an object. Draw to full scale the following views

- i) Sectional front view(section AB)
 - ii) Top view
 - iii) Right hand side view
- Insert 10 major dimensions

[5]
[4]
[4]
[2]

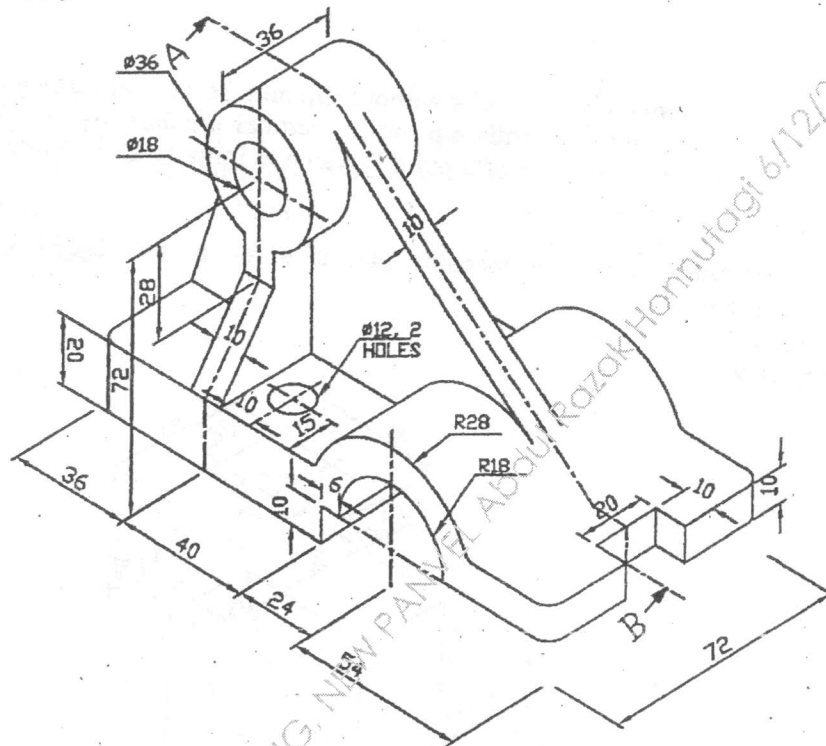

Q3 A cone, diameter of base 60mm and height 70mm has one of the generators in the HP and the plane containing the axis and that generator makes an angle 45° with VP. Draw the projections of the cone when the apex is away from the observer. [15]

Q4 A hexagonal pyramid of side of base 40mm and axis length of 70mm is resting on its base on HP with two base edges perpendicular to VP. It is cut by an auxiliary inclined plane 60° to HP and passing through a point on the axis 40mm above the base. Draw the front view, sectional top view and the true shape of the section. Also draw the development of the lateral surface of the cut pyramid after removing the portion containing the apex. [15]

Q5 a) A pentagonal prism of 40mm edge of base and 70 mm length of axis is having an edge of base in the HP and the rectangular face containing that edge is inclined 30° to HP and perpendicular to VP. Draw the projections. [6]

Con. 9435-14.

[TURN OVER

b) The orthographic projections of an object is given in the figure below. Draw [9]
the isometric view.

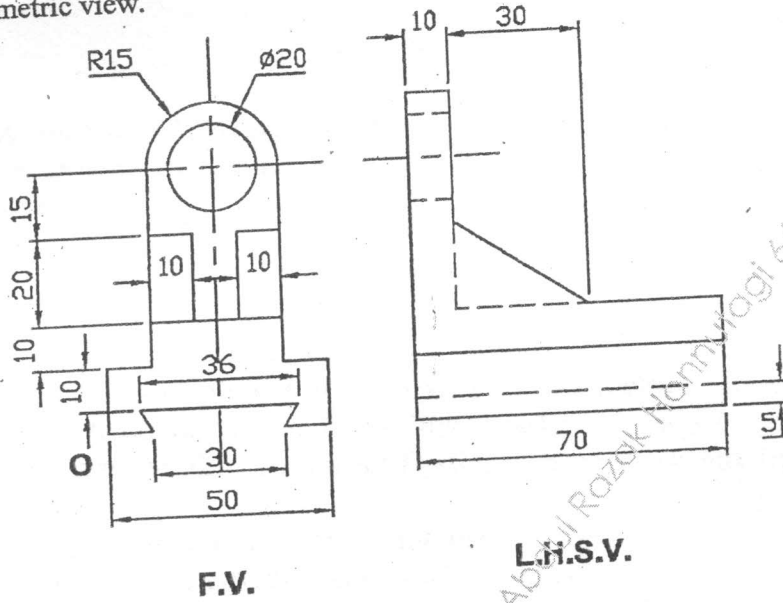

Q6 a) The top view and the front view of a line AB are 70mm and 80 mm [8]
respectively. Its end A is 15mm above HP and 20mm in front of VP. The end
B is in third quadrant. Draw the projections if the line is 100mm long. Also
find its inclination with the principal planes.

b) Draw the isometric view of the given views [7]

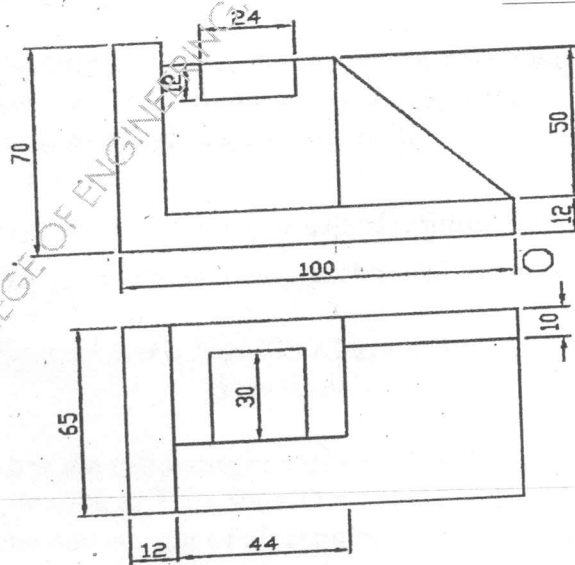

Con. 9435-14.

- (b) Explain conventional and green chemistry route of production of adipic acid. Highlight the green chemistry principle involved. 5
- (c) What is the principle of cathodic protection method of corrosion control? Explain the method of Impressed current cathodic protection. 4
4. (a) What are the drawbacks of plain carbon steels? Explain special effects of the following metals on properties of alloy steels: 6
(i) Nickel (ii) Chromium (iii) Cobalt (iv) Tungsten
- (b) With a suitable diagram and electrode reactions, explain electrochemical mechanism of rusting of iron in neutral, aqueous medium. 5
- (c) Discuss the influence of any two chemical factors on adhesive action. 4
5. (a) With a schematic diagram, explain Fixed Bed Catalytic Cracking. Mention any two advantages of catalytic cracking over thermal cracking. 6
- (b) List various steps involved in powder metallurgy. Mention the aim of each step. Give any two advantages of powder metallurgy. 5
- (c) Explain 'sandwich panel' type layered composites with a suitable diagram. Mention their application. 4
6. (a) Define 'Paint'. Mention any four constituents of paint and state functions of each constituent. 5
- (b) A sample of coal has the following composition by mass : C = 80%, H = 4%, O = 6%, S = 3%, N = 2% and Ash = 5%. Calculate Gross and Net Calorific value using Dulong's's formula. 5
- (c) What is an alloy? Explain any four purposes of alloying with suitable examples. 5

