

Sem-V/T.E/CIVIL

1/5

SA-II
18/11/2014

76

SA-II

QP Code : 14806

(3 Hours)

Total Marks : 80

- N. B. : (1) Question No. 1 is compulsory.
(2) Attempt any three questions out of remaining questions.
(3) Figures to the right indicate full marks.
(4) Assume suitable data if needed but justify the same.

- i. (a) Determine the degree of static and kinematic indeterminacy of the following structures. 6

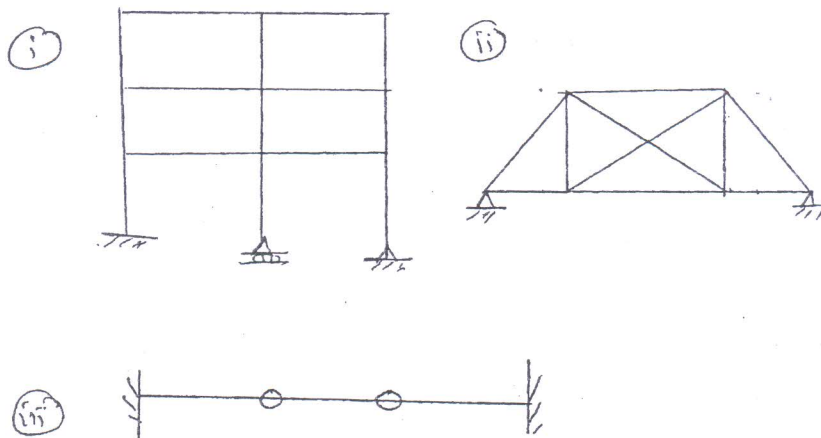

- (b) Develop the flexibility and stiffness matrix for prismatic member AB with reference to the co-ordinates shown in fig. 10

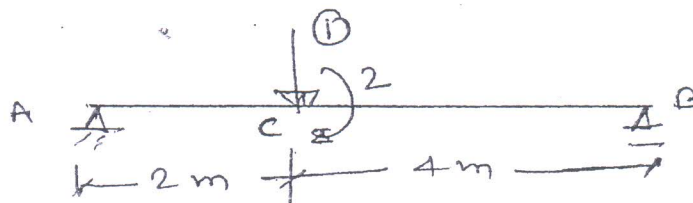

- (c) Define the following terms 4
- (i) Carry over factor
 - (ii) Distribution factor
 - (iii) Relative stiffness and modified stiffness

SA-II

QP Code : 14806

2. (a) Analyse the beam by flexibility method and draw BMD 10

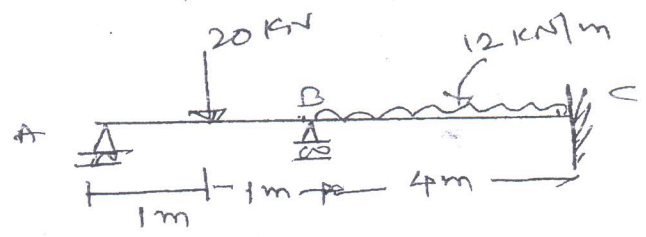

- (b) Analyse the pin jointed plane frame shown in fig. by flexibility method 10

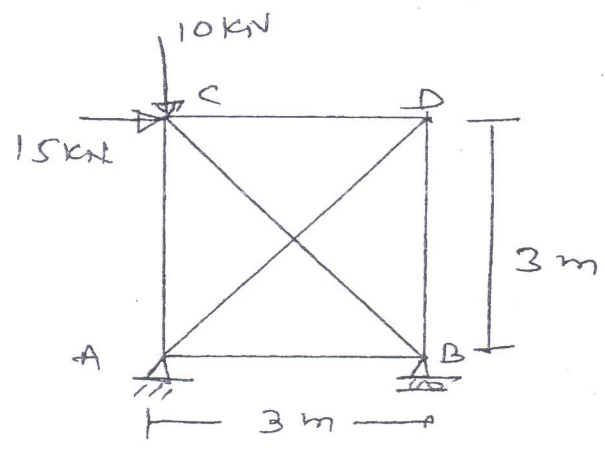

3. (a) Analyse the frame and draw BMD by using flexibility method 20

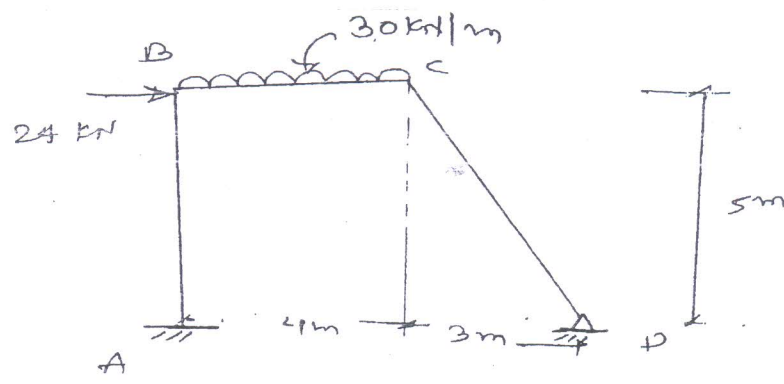

4. (a) Analyse frame by slope deflection method and draw B.M.D

12

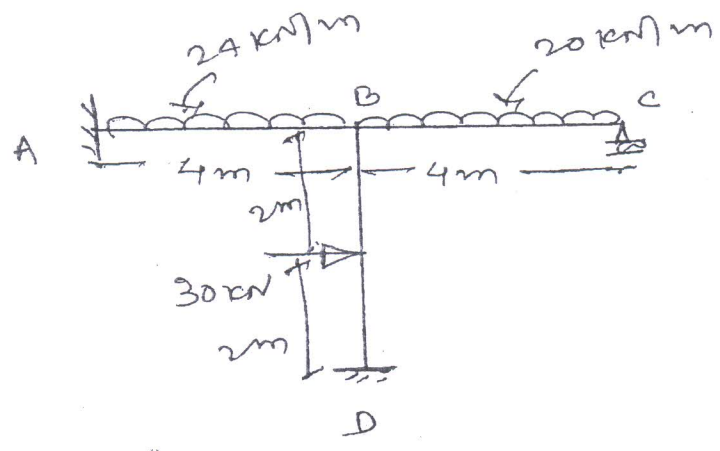

(b) Analyse the beam by three moment theorem and Draw B.M.D

8

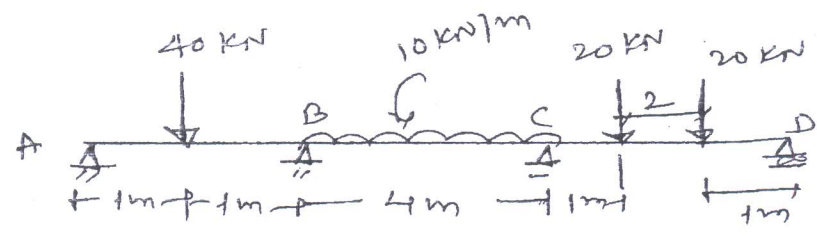

A/S

SA-II

-4-

QP Code : 14806

5. (a) Analyse the frame by moment distribution method.

12

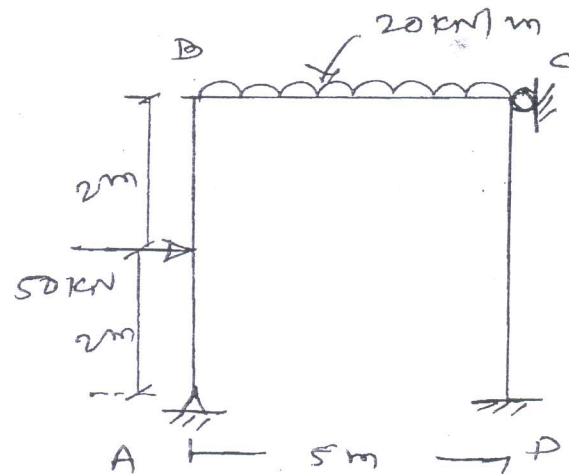

(b) Determine the plastic moment capacity for the beam as shown in fig. Take 8
Load factor 1.5

Take

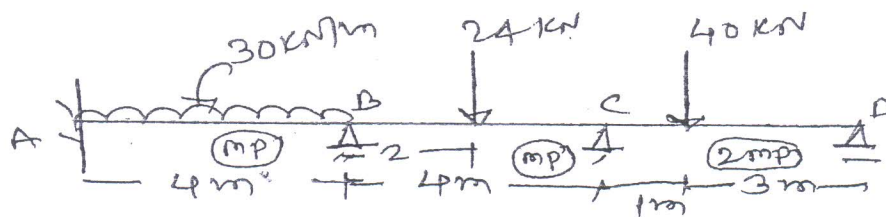

GN-Con. 5621-14.

[TURN OVER

6. (a) Analyse the frame by stiffness method and draw B.M.D

12

12

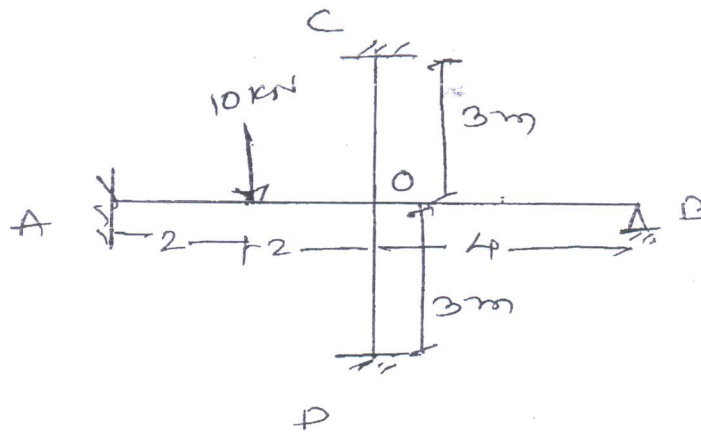

8
load (b) A two hinged parabolic arch of span 40m and rise 10 m carries uniformly distributed 10 ad of 30 k/m on right half span find the reaction at the supports and draw B.M.D. 8
