

QP Code : 1474

(3 Hours)

[Total Marks : 30

- N.E. 1) Question No. 1 is compulsory.
(2) Attempt any three questions out of the remaining five questions.
(3) Figures to the right indicate full marks.
(4) Assume suitable data wherever required with justification.

Q1. Attempt any 4

(20)

- Differentiate between Davis and Ackerman steering gears.
- Define pressure angle with respect to cams. Explain the methods to control the pressure angle.
- State and explain Law of gearing.
- What is chordal action in chain? Explain
- Explain Grubler's criteria for mobility of mechanism with example.

Q2.

- Differentiate between involute and cycloidal gear tooth profile. (06)
- A cam rotating at 200 rpm operates a reciprocating roller follower of radius 2.5 cm. The least radius of the cam is 30mm and the stroke of the follower is 5 cm. Ascent takes place by UARM and descent by SHM. Ascent takes place during 70° and descent during 50° of cam rotation. Dwell between ascent and descent is 60° . Sketch displacement, velocity, acceleration and Jerk diagrams. (14)

Q3.

- As shown in the following Fig.1, the crank OA makes 150 rpm. Find for the given configuration, the velocity of piston P by a) ICR method and b) Relative velocity method. OA=150mm, AB=375mm, AC = 400 mm, BC = 62.5 mm, BQ=200mm, CP = 450 mm. (14)

Fig.1

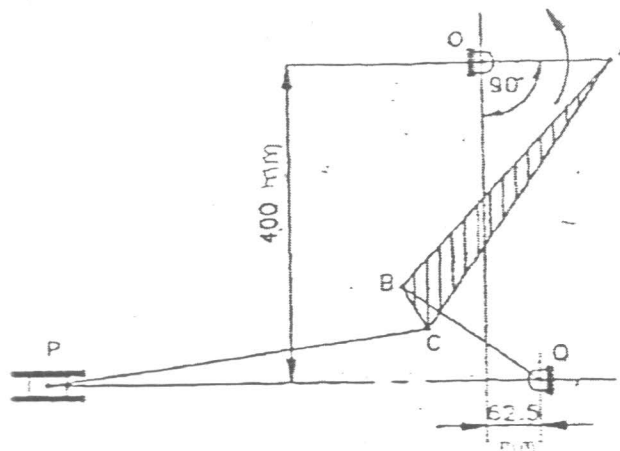

b) Explain Tchebicheff's straight line generating mechanism. (06)

Q4.

a) A right circular cylinder of radius r & mass m is suspended by a cord that is wound round its surface and the other end of the cord is held at support B, as shown in the fig.2. If the cylinder allowed to fall so that it unwinds itself under own weight, determine the acceleration of the centroid G of the cylinder and the tension T in the cord portion AB. (07)

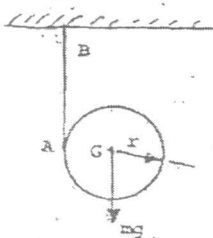

Fig.2

b) A chain drive is used for reduction of speed from 240 RPM to 120 RPM. The number of teeth on the driving sprocket is 20. Find the number of teeth on the driven sprocket. If the pitch circle diameter of the driven sprocket is 600mm and centre to centre distance between the two sprockets is 800 mm, determine the pitch and length of the chain. (07)

c) Derive the condition for the maximum power transmission by belt drive. (06)

Q5.

a) Derive the expression for minimum number of teeth on pinion to avoid interference with gear. (06)

b) Two gear wheels of diameters 75 mm and 250 mm have involute teeth of 5 mm module and 20° angle of obliquity. The addenda are equal and are as large as possible while avoiding interference. Find:

(i) The addendum (ii) The length of path of contact (07)

c) A Hooke's joint is used to couple two shafts together. The driving shaft rotates at a uniform speed of 1000 RPM. Find the greatest permissible angle between the shaft axes so that the total fluctuations of speed may not exceed 150 RPM. What will then be the maximum speed of the driven shaft? (07)

Q6

Explain the following.

(20)

- a) Coriolis's acceleration component.
- b) Peaucellier Straight line generating mechanism
- c) Inversions of slider crank chain.
- d) Methods to control interference in gears.