

**PROJECT REPORT SUBMITTED TO DEPARTMENT
OF
ELECTRICAL ENGINEERING**



**ANJUMAN-I-ISLAM'S
KALSEKAR TECHNICAL CAMPUS
SCHOOL OF ENGINEERING AND TECHNOLOGY
Affiliated to University of Mumbai**

ON

“FAUX TREE”

**SUBMITTED IN PARTIAL FULFILLMENT OF THE DEGREE OF
BACHELOR OF ELECTRICAL ENGINEERING**

**Submitted by:
SALMANI SOHRAB
SHAIKH TAUQUIR
NAVED ALI
RUPESH DAS**

**Under Guidance of:
PROF.ANKUR UPADHYAY**

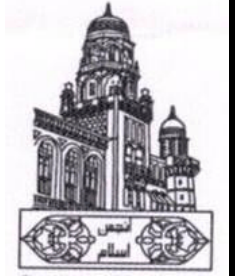

**ANJUMAN-I-ISLAM'S
KALSEKAR TECHNICAL CAMPUS**

School of Engineering & Technology

Plot No-2&3, Near Thana Naka, Sector-16, Khandagaon, New Pnavel-410206

Affiliated to University of Mumbai

CERTIFICATE

This is to certify that project entitled “**Faux Tree**” undertaken at the Department of Electrical Engineering by **Mr. Salmani Sohrab(12EE97), Mr. Tauquir Shaikh(12EE102), Mr.Naved Ali(12EE103), Mr. Rupesh R Das(12EE114)** in partial fulfillment of B.E. (Electrical Engineering) degree Semester VIII Examination as syllabus of University of Mumbai for academic year 2014-2015.It is further certified that he has completed all required phases of the project.

Signature of Internal guide

Signature of HOD

Signature of External Examiner

ACKNOWLEDGEMENT

We take this opportunity to express our deep sense of gratitude to our guide **Prof. Ankur Upadhyay** for his valuable guidance and inspiration in spite of his busy schedule. He devoted himself in completing our task with the admirable excellence. He has taken keep and personal interest in giving us constant encouragement and timely suggestions also to our HOD **Prof. Sayed Kaleem** for cheerful encouragement and notable guidance.

Our special thanks to our electrical staff, who gave precious guidelines for our project “**FAUX TREE**” and supporting staff members of electrical department for their valuable help in our paper.

We also express our heart full thanks to our beloved Principal **Mr. Abdul Razzak Honnutagi** has provided the facilities for paper, we are also thankful to our friends.

Really it is highly impossible to repay the debt of all the people who have directly or indirectly helped us for performing the project.

Date-

Place-

TABLE OF CONTENTS

FAUX TREE

1. INTRODUCTION

- 1.1 How this Artificial Tree or Machine will work?

2. SYSTEM BLOCK DIAGRAM

2.1 Components of Block Diagram

- 2.1.1 Vertical Axis Windmill and its Working

- 2.1.2 Leaf type PV module

- a) How PV panel work

- b) Details on How PV panel work

- 2.1.3 LDR or Light Dependent Resistor

- a) How an LDR works

- 2.1.4 LED Eco-Lighting

- 2.1.5 Water Electrolysis

- a) Principle of Electrolysis

- 2.1.6 LCD Display

- a) General Specification

- 2.1.7 Thermistor

3. CIRCUIT DIAGRAM

3.1 Working of Circuit Diagram

- 3.1.1 Power Supply

- a) Transformer only

- b) Transformer + Rectifier

c) Transformer + Rectifier + Smoothing

3.1.2 Voltage Regulator

3.1.3 Typical Application Circuit

4. DEVELOPEMENT STAGES AND PROCESS

4.1 Problem Defination Stage

4.2 Designing Block Digram

4.3 Implementing Circuits and Components

4.4 Developing algorithm for software

4.5 Writing actual code for microcontroller

4.6 Compiling the code

4.7 Burning the hex file into microcontroller with programmer

4.8 Testing and running

5. FABRICATION OF PCB

5.1 PCB making

5.2 Designing the layout

5.3 Soldering

6. TESTING AND TROUBLESHOOTING

A) APPLICATION

B) BENEFITS

C) ADVANTAGES

D) DISADVANTAGES

CONCLUSION

BIBLIOGRAPHY AND REFERENCE

CHAPTER - 1

1. INTRODUCTION



Trees naturally convert the carbon dioxide into oxygen. But today because of Greed Selfish Humans are cutting trees and forests and on that place we humans are building white cement forest. Thus we humans are not getting pure air. Population is increasing and number of tress are decreasing , just like mad society people are cutting tress after tress , even they are cutting hills to build a building to earn money.Co2 is not good for humans but Trees convert water into oxygen which we humans need to survive. This will lead to Global warming problems, Acid

FAUX TREE

Rain, respiratory disease many more. But do not worry now Artificial Trees will do this Job in future. Research and experimentation on the concept of lighting; innovation and technology in the utilization and control of light; extreme attention to eco-compatible materials and to environmental needs in general; a deeply rooted vocation for fine design: these are the values that distinguish Arsenide and the principles that underlie this new concept of public lighting. Solar oxygen Tree is the successful marriage of the most advanced technology and the aesthetic requirements of the urban environment by way of renewable energy. Arsenide has dedicated its formidable skill and commitment to realizing these objectives, driven by a passion for research and sustainability and by an innate love of excellent design.

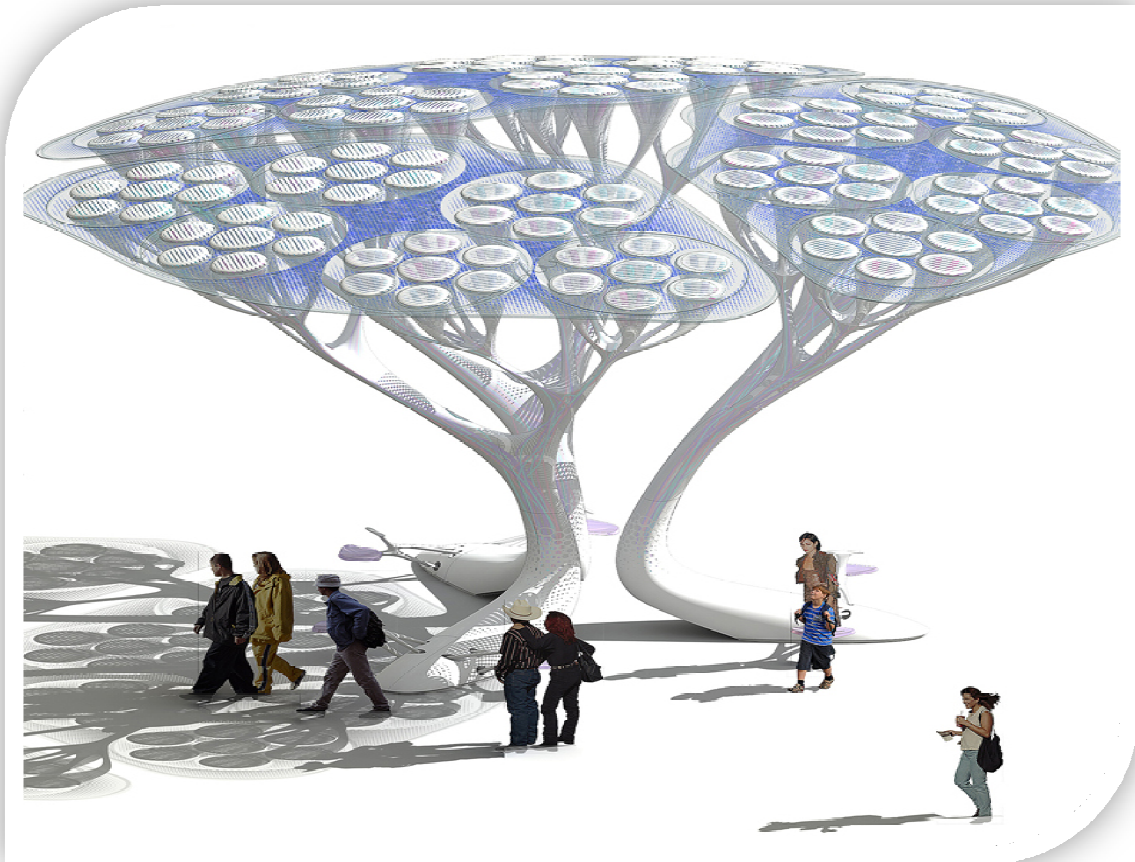

1.1 How this Artificial Tree or Machine will work?

It's not nice to fool Mother Nature. Or is it? If you're not getting enough air, you might want to spend time sitting under a newly designed artificial tree that converts day light into electricity using solar modules connected as leaf on tree for electrolysis process of waste water into oxygen & hydrogen. Oxygen will be released to air and hydrogen can be used to fuel vehicles of future. As well as LED lights connected on tree leaf will radiate light in night time acting as a street light. In the modern world of urban pollution, we can't seem to grow enough trees to naturally convert carbon dioxide into life-sustaining air — the process of photosynthesis — until now.



Oxygen tree is a revolutionary urban lighting concept that represents a perfect symbiosis between pioneering design and cutting-edge eco-compatible technology. Solar Tree opens up new prospects for urban lighting in that it satisfies today's most pressing environmental, social, cultural and aesthetic demands. The ability to combine innovative design with advanced technology, along with an acute sensitivity to environmental concerns make Artemide the ideal vehicle for the development of this project conceived by Ross Lovegrove, with the collaboration of Sharp Solar, the world's leading manufacturer of solar cells.

After trial and error they realize that Solar Panel will not be enough to power the Tree, thus they have added 2nd option to the artificial tree. The groves of tree pods will be paired with hammocks

and see-saws that will help to power the devices If we Humans start to save the trees we won't need these artificial trees to produce oxygen.



But still we will need these artificial trees to produce the Oxygen as humans have started to build very tall buildings and as we go higher and higher Oxygen level gets reduced and one will need these artificial trees to produce Oxygen in 100th floor Apartment or 50th floor apartment. With the earth's population ever growing, air pollution and air quality is a major issue for many countries around the world. Air pollutants can lead to respiratory related illnesses in humans and animals, create acid rain, and deplete the ozone layer. Actions such as carpooling, reducing the use of fossil fuels, and simply turning off a light when leaving a room are all ways that reduce harmful CO₂ levels in our atmosphere. There is also a natural source that eats away at harmful CO₂ gases and that source is trees.

Trees act like nature's lungs. They take in CO₂ gases from the air and then use those gases for energy during the photosynthesis process. A byproduct of photosynthesis is oxygen. Over the course of a year, one tree can absorb up to 13 pounds of CO₂ gases. The loss of trees in cities has had devastating results. Heavy levels of CO₂ gases in cities create thick smog and affect the natural ecosystem of the land. These concentrated levels of CO₂ gases create a hostile environment for trees and plants, making it difficult for them to grow properly.

CHAPTER - 2

2. SYSTEM BLOCK DIAGRAM

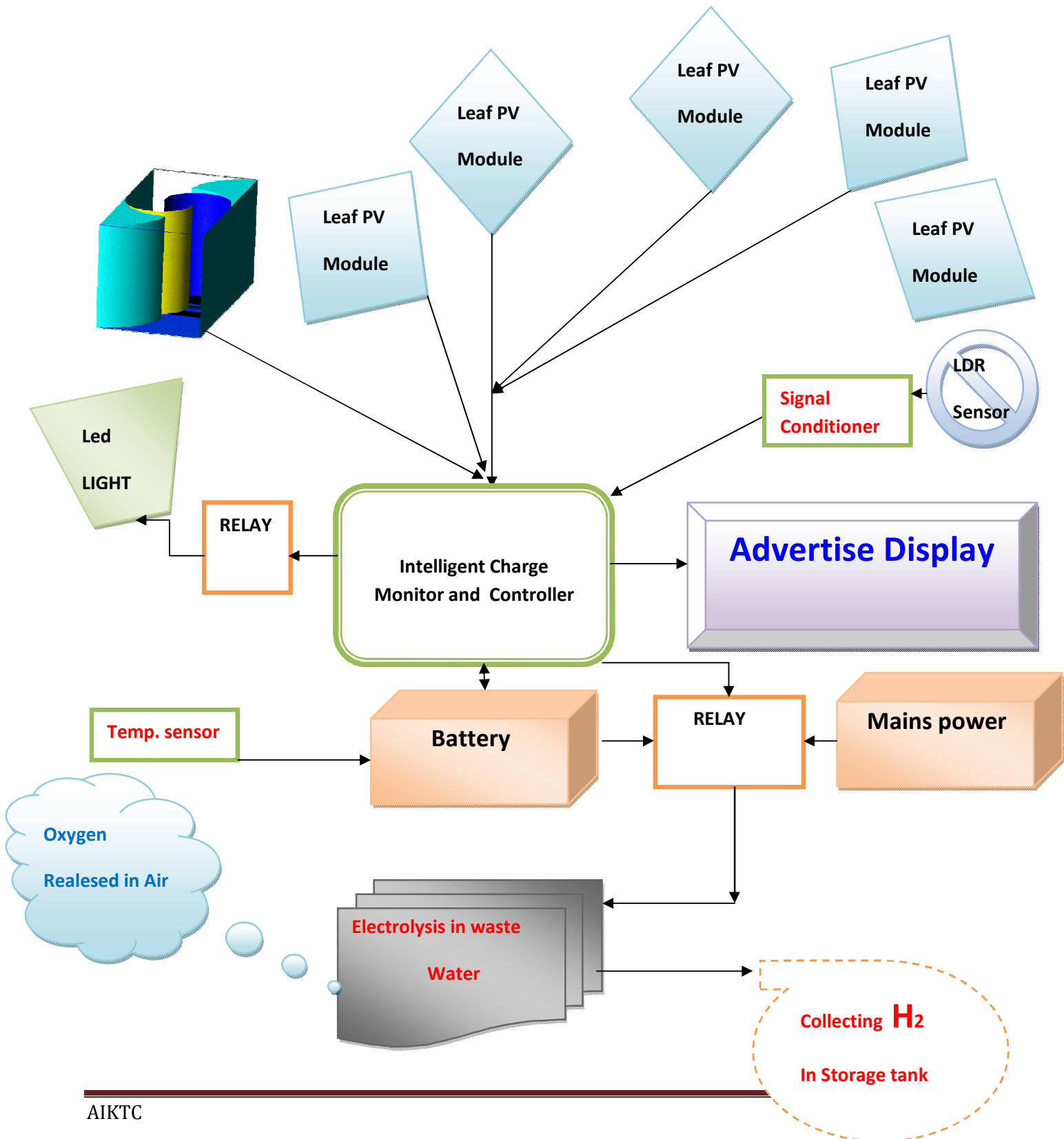

2.1 Components of Block Diagram

2.1.1 Vertical Axis Windmill

Vertical axis windmill is a complicated but innovative design, probably the most complex for a wind power harnessing structure. Though the mechanism is not like that of any other conventional windmill, it works on the same principle of wind power generation.

The design of vertical windmill is based around a continuously rotating carousel, which comprises of symmetrical airfoils. The main feature of the windmill is that the whole system is mounted on a fixed vertical shaft. The vertical shaft remains stationary but airfoils can move 360 degrees, independent of the main shaft.

Working

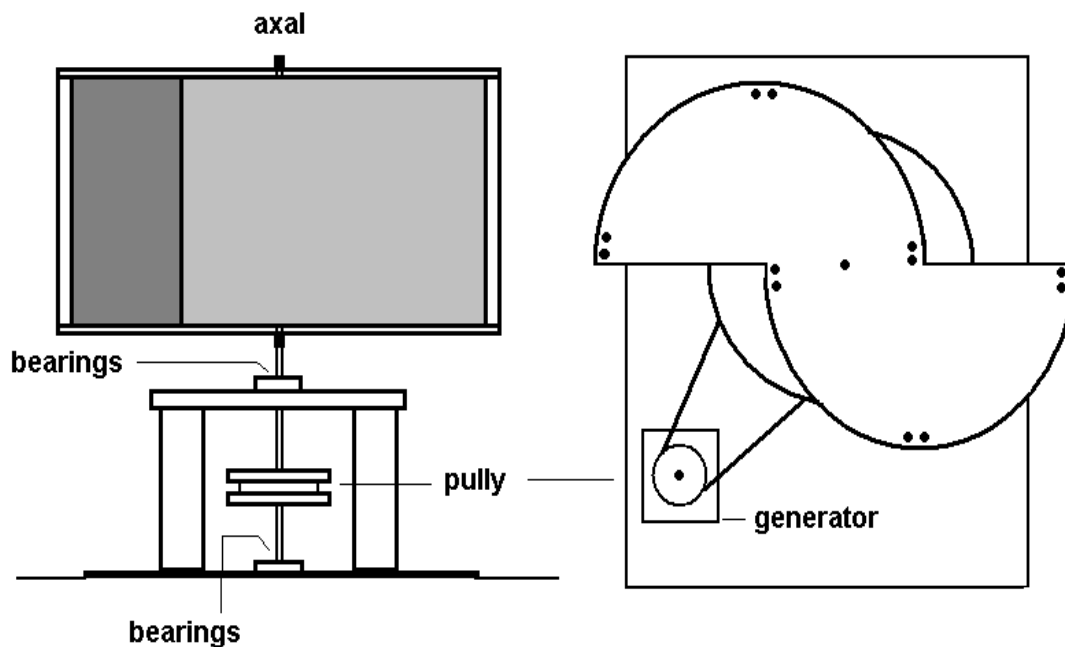

Each airfoil can be rotated around its own axis with the help of a top mounted central weather vane. The central vane keeps the cam shaft pointed at the winds. In high intensity winds, the airfoils can be rotated to a zero angle of attack in order to prevent any kind of damage.

The main central fixed shaft is heavy and can withstand any possible wind load.

In order to make the structure lighter and less complex, the airfoils are attached to the carousel at the top and bottom. This gives the main spar of the airfoils extra freeness to rotate and also makes the overall structure lighter. The central weather vane and the cam moves extremely slowly and only with shifting wind direction.

All the forces experienced by the airfoil are transferred to the carousel through the airfoil's mounting bearings. The push rod and bell cranks don't perform much work. They just control the attitude of airfoils, close to their center of lift. The airfoils are so mounted that their point of rotation is forward of their center of lift. This will allow them to have a natural tendency to weather vane.

One disadvantage of the horizontal axis mill is that, for all but the short mills, the axis needs to be supported at each end. This means they sometimes need a clumsy supporting structure around them limiting the height above ground they can reasonably be positioned. As wind speed is usually greater and more stable high above the ground its a major limitation for these otherwise excellent devices.

This particular design uses 10 mm studding (thread) as an axle to support the wind turbine and transmission gearing (a 15cm diameter wooden pulley). Everything is made from 1/2" plywood coated with several varnish layers to weather proof. As its fairly small we support the whole turbine from the base.

2.1.2 Leaf type PV module

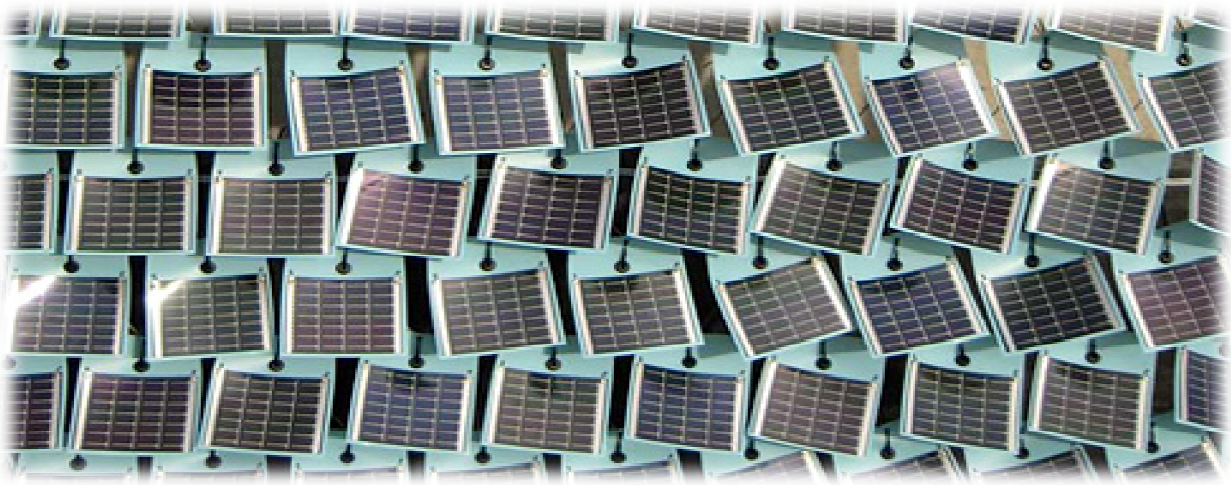

There are two main types of solar panels 1) solar electric panels and 2) solar water heating panels. We'll discuss water heating later. Right now, let's talk about solar photovoltaic (PV) panels, which provide electricity.

a) How PV Panels Work

PV panels collect energy from the sun and convert it into electricity. PV systems convert sunlight directly into electricity. “Photo” refers to light and “voltaic” to electricity. A PV cell is made of a semiconductor material, usually crystalline silicon, which absorbs sunlight. You’ve seen PV cells at work in simple mechanisms like watches and calculators. You’ve probably even seen them for signs on the road. More complex PV systems produce solar electricity for houses and the utility grid. The utility grid is the power source available to your local electricity provider. PV cells are typically combined into modules, or panels, containing about 40 cells. Roughly ten modules constitute a PV array, or grouping of panels.

b) Details on How PV Panels Work

Most PV panels contain a top protective layer, two specially treated layers of silicon with collecting circuitry attached to the top layer, and a polymer backing layer. The top layer of silicon is treated to make it electrically negative; the back layer is treated to make it electrically positive. When sunlight knocks electrons loose from the silicon, electrons move up from the bottom layer of silicon and crowd the electrons in the top layer. The electrons freed from the top layer are

collected by electrical contacts on the surface of the top layer and routed through an external circuit, thus providing power to the electrical system attached to the panels.

New technology, which we'll get to in a later section, uses different, less expensive materials than silicon in PV panels to capture sunlight more affordably.

2.1.3 LDR or Light Dependent Resistor

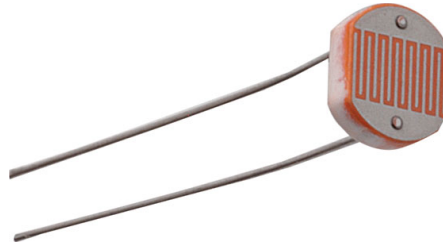

A photoresistor or light dependent resistor is a component that is sensitive to light. When light falls upon it then the resistance changes. Values of the resistance of the LDR may change over many orders of magnitude the value of the resistance falling as the level of light increases. It is not uncommon for the values of resistance of an LDR or photoresistor to be several megohms in darkness and then to fall to a few hundred ohms in bright light. With such a wide variation in resistance, LDRs are easy to use and there are many LDR circuits available. LDRs are made from semiconductor materials to enable them to have their light sensitive properties. Many materials can be used, but one popular material for these photoresistors is cadmium sulphide (CdS).

a) How an LDR works

It is relatively easy to understand the basics of how an LDR works without delving into complicated explanations. It is first necessary to understand that an electrical current consists of the movement of electrons within a material. Good conductors have a large number of free electrons that can drift in a given direction under the action of a potential difference. Insulators with a high resistance have very few free electrons, and therefore it is hard to make them move and hence a current to flow. An LDR or photoresistor is made any semiconductor material with a high resistance. It has a high resistance because there are very few electrons that are free and able to move - the vast majority of the electrons are locked into the crystal lattice and unable to move. Therefore in this state there is a high LDR resistance. As light falls on the semiconductor, the light photons are absorbed by the semiconductor lattice and some of their energy is transferred to the electrons. This gives some of them sufficient energy to break free from the crystal lattice so that they can then conduct electricity. This results in a lowering of the resistance of the semiconductor and hence the overall LDR resistance.

2.1.4 LED Eco Lightning



Nowadays every person tries to save energy and be part of making our world greener and a better place to live. The largest users of electricity are governments and metropolitans that want to illuminate their streets to make them safer to walk through. For that the traditional streetlights are massive consumers of electricity that are a big part of our contamination of our world. Large electricity plants consume a huge amount of coal and carbon to let those lights of all metropolitans and cities burn at least 8 hours a day. But what if we can reduce the use of electricity for those metropolitans and cities upto 80% less and still be illuminated? How can that be done?? With high power LED streetlights it is possible to achieve to save upto 80% of energy, and besides they cost less to maintain.

2.1.5 Water Electrolysis

a) Principal of Electrolysis

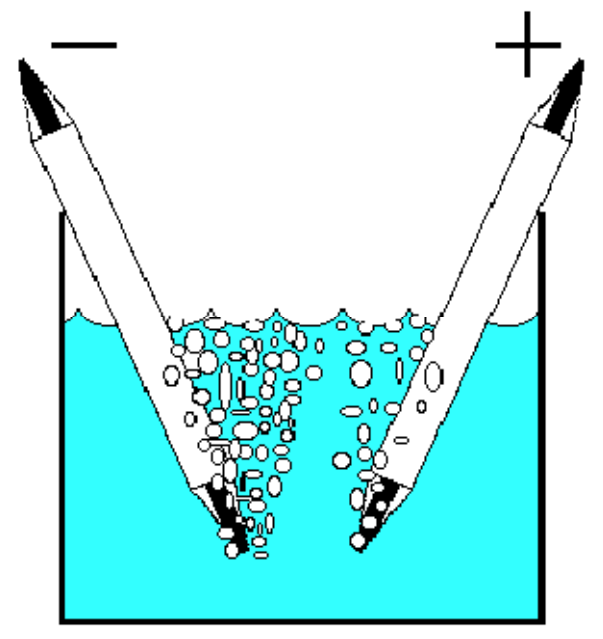

Water electrolysis to produce hydrogen and oxygen is an old technology originating in the early 19th century shortly after Volta introduced the first battery in 1800. The principle chemical equations are shown in **figure**, where the electrochemical flow is shown for acidic and alkaline environments. This work involves the alkaline reaction pathway. To understand the principles of electrolysis, perhaps the most basic experiments is the use of two pencils sharpened at both ends with the top being connected to a battery and the 3 of 11 bottoms inserted into alkaline water. **Figure** illustrates the concept showing many bubbles appearing at the negative pencil and half that many appearing at the positive. The reactions are:

Positive: $2\text{OH}^- \rightarrow \frac{1}{2}\text{O}_2 +$

$\text{H}_2\text{O} + 2\text{e}^-$

Negative: $2\text{H}_2\text{O} + 2\text{e}^- \rightarrow \text{H}_2 + 2\text{OH}^-$

is the same principle of even the most sophisticated water electrolysis machines with the difference being in efficiency and production rate as discussed above.

2.1.6 LCD Display



Various display device such as seven segment display, LCD display, etc can be interfaced with microcontroller to read the output directly. In our project we use a two line LCD display with 16 characters each. Liquid crystal Display (LCD) displays temperature of the measured element, which is calculated by the microcontroller. CMOS technology makes the device ideal for application in hand held, portable and other battery instruction with low power consumption.

a) General Specification

- Drive method: 1/16 duty cycle
- Display size: 16 character * 2 lines
- Character structure: 5*8 dots.
- Display data RAM: 80 characters (80*8 bits)
- Character generate ROM: 192 characters
- Character generate RAM: 8 characters (64*8 bits)
- Both display data and character generator RAMs can be read from MPU.
- Internal automatic reset circuit at power ON.
- Built in oscillator circuit.

2.1.7 Thermistor

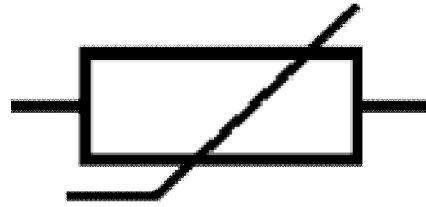
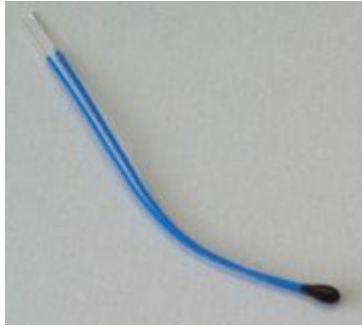

A **thermistor** is a type of resistor with resistance varying according to its temperature. The word is a portmanteau of *thermal* and *resistor*. Thermistors are widely used as inrush current limiters, temperature sensors, self-resetting overcurrent protectors, and self-regulating heating elements. Assuming, as a first-order approximation, that the relationship between resistance and temperature is linear, then:

$$\Delta R = k\Delta T$$

where

ΔR = change in resistance

ΔT = change in temperature

k = first-order temperature coefficient of resistance

Thermistors can be classified into two types depending on the sign of k . If k is positive, the resistance increases with increasing temperature, and the device is called a positive temperature coefficient (**PTC**) thermistor, or **posistor**. If k is negative, the resistance decreases with increasing temperature, and the device is called a negative temperature coefficient (**NTC**) thermistor. Resistors that are not thermistors are designed to have a k as close to zero as possible, so that their resistance remains nearly constant over a wide temperature range.

Thermistors differ from resistance temperature detectors in that the material used in a thermistor is generally a ceramic or polymer, while RTDs use pure metals. The temperature response is also different; RTDs are useful over larger temperature ranges.

CHAPTER - 3

3. CIRCUIT DIAGRAM

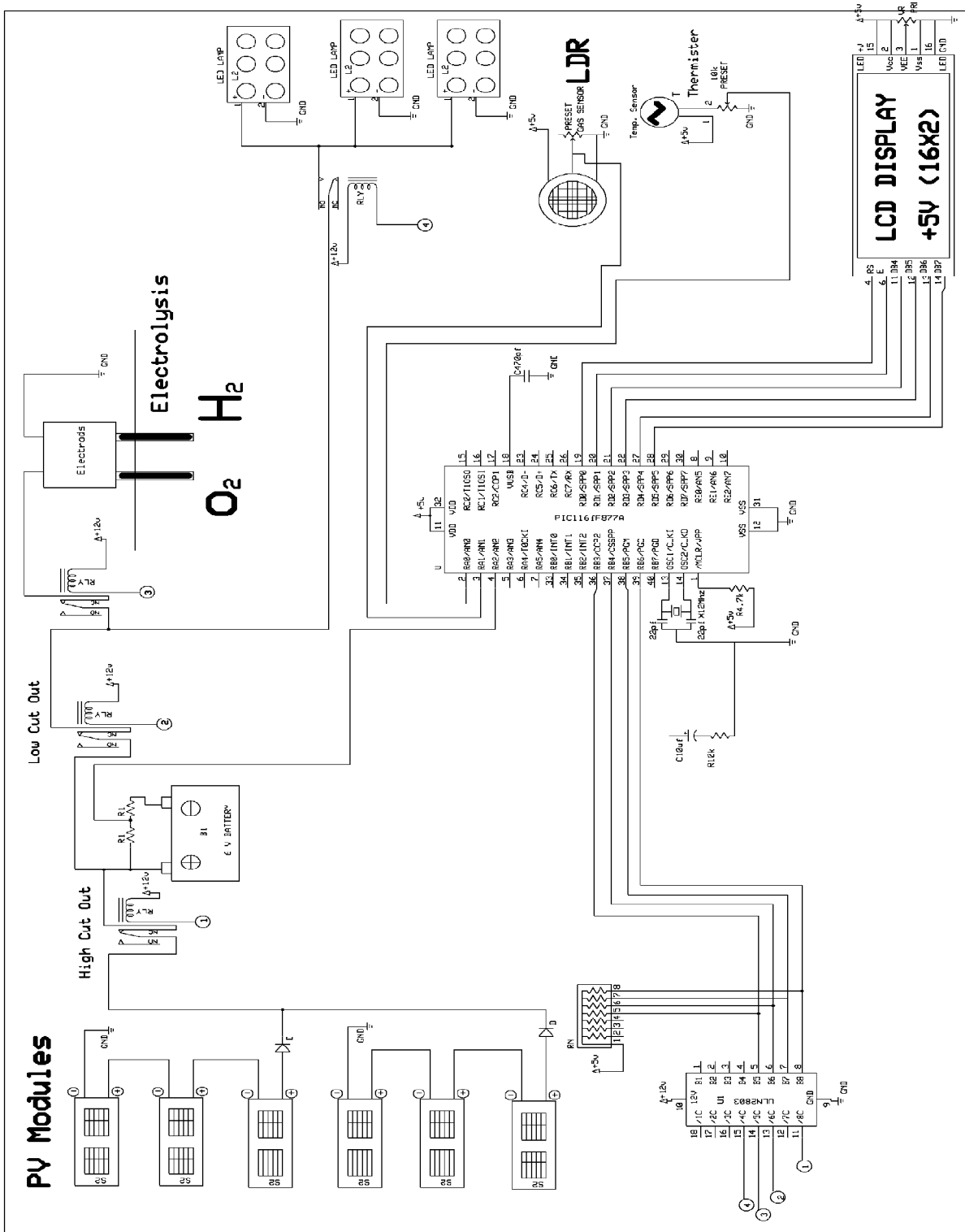

3.1 Working of Circuit Diagram

3.1.1 Power Supply

There are many types of power supply. Most are designed to convert high voltage AC mains electricity to a suitable low voltage supply for electronic circuits and other devices. A power supply can be broken down into a series of blocks, each of which performs a particular function.

For example a 5V regulated supply:

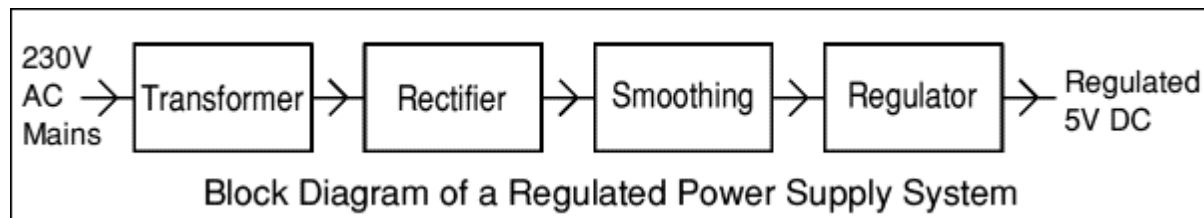

Each of the blocks is described in more detail below:

- Transformer - steps down high voltage AC mains to low voltage AC.
- Rectifier - converts AC to DC, but the DC output is varying.
- Smoothing - smoothes the DC from varying greatly to a small ripple.
- Regulator - eliminates ripple by setting DC output to a fixed voltage.

Power supplies made from these blocks are described below with a circuit diagram and a graph of their output:

- Transformer only
- Transformer + Rectifier
- Transformer + Rectifier + Smoothing
- Transformer + Rectifier + Smoothing + Regulator

a) Transformer only

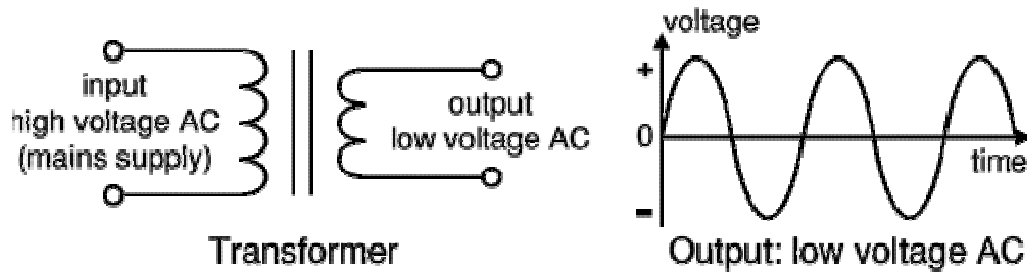

The **low voltage AC** output is suitable for lamps, heaters and special AC motors. It is **not** suitable for electronic circuits unless they include a rectifier and a smoothing capacitor.

b) Transformer + Rectifier

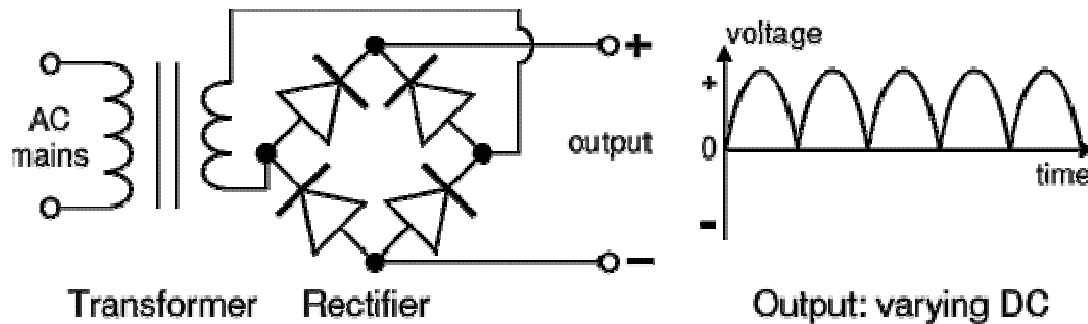

The **varying DC** output is suitable for lamps, heaters and standard motors. It is **not** suitable for electronic circuits unless they include a smoothing capacitor. Rectifier unit is a ckt. which converts A.C. into pulsating D.C. Generally semi-conducting diode is used as rectifying element due to its property of conducting current in one direction only. Generally there are two types of rectifier.

- 1) Half wave rectifier
- 2) Full wave rectifier.

c) Transformer + Rectifier + Smoothing

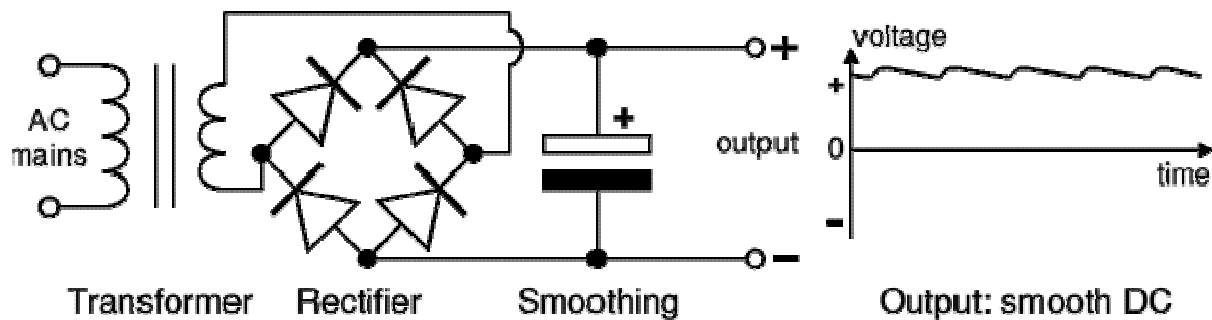

The **smooth DC** output has a small ripple. It is suitable for most electronic circuits.

d) Transformer + Rectifier + Smoothing + Regulator

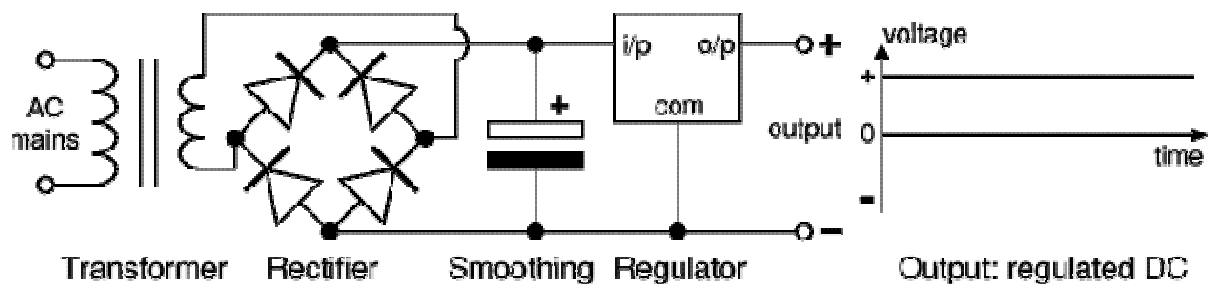

The **regulated DC** output is very smooth with no ripple. It is suitable for all electronic circuits.

The fig. above shows the circuit diagram of the power supply unit. This block mainly consists of a two regulating IC 7805 and a bridge rectified and it provides a regulated supply approximately 5V.

The transformer used in this circuit has secondary rating of 7.5V. The main function of the transformer is to step down the AC voltage available from the main. The main connections are given to its primary winding through a switch connected to a phase line. The transformer provides a 7.5V AC output at its secondary terminals and the maximum current that can be drawn from the transformer is 1 Amp which is well above the required level for the circuit.

The bridge rectified the AC voltage available from the secondary of the transformer, i.e. the bridge rectifier convert the AC power available into DC power but this DC voltage available is not constant. It is a unidirectional voltage with varying amplitude.

To regulate the voltage from the bridge rectifier, capacitors are connected. Capacitors C1 filter the output voltage of the rectifier but their output is not regulated and hence 7805 is connected which is specially designed for this purpose.

Although voltage regulators can be designed using op-amps, it is quicker and easier to use IC voltage regulator. Further more, IC voltage regulators are available with features such as programmable output current/ voltage boosting, internal short circuit current limiting, thermal shut down and floating operation for high voltage applications.

The 78 XX series consists of three terminals viz, input, output & ground. This is a group of fixed positive voltage regulator to give an output voltage ranging from 5V to 24V. These IC's are designed as fixed voltage regulators and with adequate heat sinking, can deliver output current in excess of 1 Amp although these devices do not require external components and such components can be used to obtain adjustable voltage and current limiting. In addition, the difference between the input and output voltages (V_{in} in V_o) called the dropout voltage must be typically 2V even from a power supply filter. Capacitors C2, C3, C4, and C5 are small filters which are used for extra filtering. LED1 & LED2 are used for Power ON indicator for IC1 and IC2, current-limiting resistors R2 & R4, which prevents the LED's from getting heated and thus damaged.

3.1.2 Voltage Regulator

A voltage regulator is an electrical regulator designed to automatically maintain a constant voltage level. It may use an electromechanical mechanism, or passive or active electronic components. Depending on the design, it may be used to regulate one or more AC or DC voltages. With the exception of shunt regulators, all voltage regulators operate by comparing the actual output voltage to some internal fixed reference voltage. Any difference is amplified and used to control the regulation element. This forms a negative feedback servo control loop. If the output voltage is too low, the regulation element is commanded to produce a higher voltage. If

the output voltage is too high, the regulation element is commanded to produce a lower voltage. In this way, the output voltage is held roughly constant.

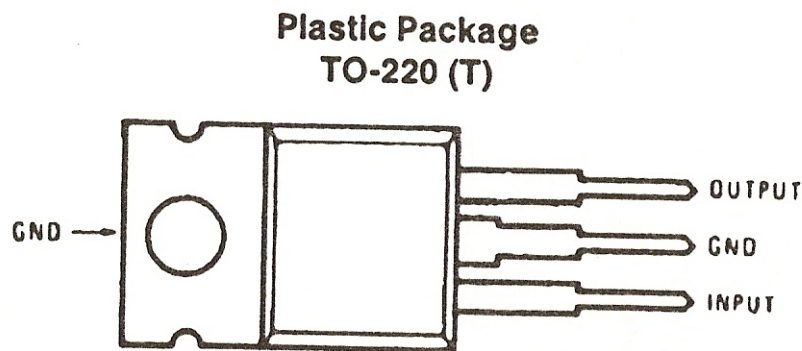

**Order Number LM7805CT,
LM7812CT or LM7815CT
See NS Package Number T03B**

Features

- Output current in excess of 1A
- Internal thermal overload protection
- No external components required
- Output transistor safe area protection
- Internal short circuit current limit
- Available in the aluminum TO-3 package

3.1.3 Typical Application Circuit

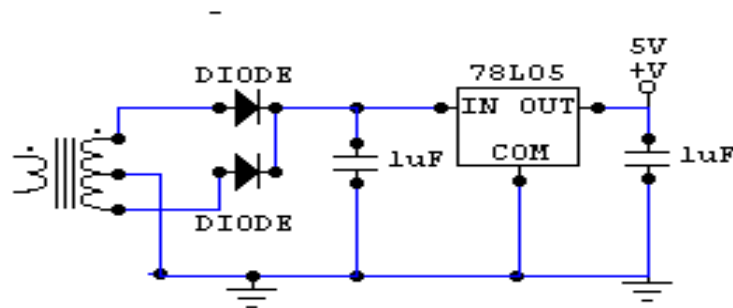

In our project we require power supply of 5V. From the mains supply we get 230V, 50 Hz. So to convert that configuration into the required configuration we need to use following circuits with signal conditioners:

- STEP DOWN TRANSFORMER
- FULL WAVE BRIDGE RECTIFIER
- FILTER CONDENSER
- D.C. REGULATED 3 PIN I.C.

Transformer here used is the **CENTER TAPPED STEP DOWN TRANSFORMER**. The primary winding turns are greater than that of the secondary. Input supply to primary is 230V, 50 Hz that produces the 0-24V at the secondary. Secondary of the transformer is connected to the **FULL WAVE BRIDGE RECTIFIER**. It gives unipolar waveform of the transformer output. It converts the a.c. supply into d.c. voltage.

Output at the bridge rectifier is:

$$V_{dc} = 2 * (V_{in}) / \pi$$

$$V_{rms} = V_m / \sqrt{2}$$

But output obtained from the rectifier is not complete ripple free and contains the ac nature. Thus it needs to be smoothed using **FILTER CONDENSER**. Here the capacitor assembly allows only its rated voltage through it for one cycle. Property of capacitor to be insensitive to the high frequency at the input side helps to have smooth output.

Sometimes, due to mains power supply fluctuation and the ageing of the circuit components the output fails to remain at constant level. Thus we need to add the **VOLTAGE REGULATORS**.

Due to the high voltage operating temperatures there may be heat generation, which leads to the sparks or may even catch fire and damage the whole circuitry. Thus we use heat sink. All the output is then connected to the connector to provide the supply for remaining circuit.

CHAPTER - 4

4.DEVELOPMENT STAGES & PROCESS

The complete development of this system can be divided into the following stages:

- Problem definition stage;
- Designing block diagram;
- Implementing circuits and components;
- Developing algorithm for software;
- Writing actual code for Microcontroller;
- Compiling the code;
- Burning the hex file into microcontroller with programmer;
- Testing and Running.

4.1 Problem definition stage

This is the very first stage to develop any project. It actually defines the aim and the concept of the project. The aim of “**Microcontroller Based Data Acquisition and Controlling System with PC interface**” is to design a DAS which can be connected to any type of computer serial port giving the user flexibility of selection of desired number of channels for data acquisition with least complexity and cost.

4.2 Designing block diagram

At this stage we have categorized the whole system into different individual modules. These modules (block diagrams) will be helpful in understanding the concept and working of the integrated system. It also simplifies the entire debugging and testing process.

4.3 Implementing circuits and components

This is the actual implementation of circuit of each block. At this stage we have actually designed each block separately and finally integrated them into the complete working system.

4.4 Developing algorithm for software

To get the logical flow of the software, the development of algorithm is having a prominent role. So that we have analyzed the complete system and organized the algorithm in such a manner that one can understand the complete working of the software.

4.5 Writing actual code for Microcontroller

After the development of the algorithm and flowchart we have actually translated them in C language for Atmel 89C51 Microcontroller so that it can understand the instructions and run as per our requirement. The instructions are in ANSII C Language.

4.6 Compiling the code

The code is implemented on the computer for which we have used Keil pre-installed on PC. The Keil is a Computer Aided Program to simulate the working of Microcontroller in real time without burning the software into actual IC. We simulated and compiled our program for error checking.

4.7 Burning the hex file into microcontroller with Programmer

In this stage the compiled hex format file was downloaded or burned into Atmel AT89C51 flash Microcontroller. This was done with the help of FP-8903 Programmer for Atmel microcontrollers designed by Oriole Electronics Pvt. Ltd.

4.8 Testing and Running

This time we tested our project for actual working, after loading the software into the microcontroller. Any errors found were removed successfully. This is the last and final stage of development of our project.

CHAPTER - 5

5.FABRICATION OF PCB

5.1 P.C.B. MAKING

- + P.C.B. is printed circuit board which is of insulating base with layer of thin copper-foil.
- + The circuit diagram is then drawn on the P. C. B. with permanent marker and then it is dipped in the solution of ferric chloride so that unwanted copper is removed from the P.C.B., thus leaving components interconnection on the board.
- + The specification of the base material is not important to know in most of the application, but it is important to know something about copper foil which is drawn through a thin slip.
- + The resistance of copper foil will have an affect on the circuit operation.
- + Base material is made of lamination layer of suitable insulating material such as treated paper, fabric; or glass fibers and binding them with resin. Most commonly used base materials are formed paper bonded with epoxy resin.
- + It is possible to obtain a range of thickness between 0.5 mm to 3 mm.
- + Thickness is the important factor in determining mechanical strength particularly when the commonly used base material is “**Formea**” from paper assembly.
- + Physical properties should be self supporting these are surface resistivity, heat dissipation, dielectric, constant, dielectric strength.
- + Another important factor is the ability to wishstand high temperature.

5.2 DESIGNING THE LAYOUT

- + While designing a layout, it must be noted that size of the board should be as small as possible.
- + Before starting, all components should be placed properly so that an accurate measurement of space can be made.
- + The component should not be mounted very close to each other or far away from one another and neither one should ignore the fact that some component need ventilation,

- which considerably the dimension of the relay and transformer in view of arrangement, the bolting arrangement is also considered.
- + The layout is first drawn on paper then traced on copper plate which is finalized with the pen or permanent marker which is efficient and clean with etching.
 - + The resistivity also depends on the purity of copper, which is highest for low purity of copper. The high resistance path are always undesired for soldered connections.
 - + The most difficult part of making an original printed circuit is the conversion from, theoretical circuit diagram into wiring layout. without introducing cross over and undesirable effect.
 - + Although it is difficult operation, it provides greater amount of satisfaction because it is carried out with more care and skill.
 - + The board used for project has copper foil thickness in the range of 25 40 75 microns.
 - + The soldering quality requires 99.99% efficiency.
 - + It is necessary to design copper path extra large. There are two main reasons for this,
 - i) The copper may be required to carry an extra large overall current:-
 - ii) It acts like a kind of screen or ground plane to minimize the effect of interaction.
 - + The first function is to connect the components together in their right sequence with minimum need for interlinking i.e. the jumpers with wire connections.
 - + It must be noted, that when layout is done, on the next day it should be dipped in the solution and board is move continuously right and left after etching perfectly the board is cleaned with water and is drilled.
 - + After that holes are drilled with 1 mm or 0.8 mm drill. Now the marker on the P. C. B. is removed.
 - + The Printed Circuit Board is now ready for mounting the components on it.

5.3 SOLDERING

- + For soldering of any joints first the terminal to be soldered are cleaned to remove oxide film or dirt on it. If required flux is applied on the points to be soldered.

- + Now the joint to be soldered is heated with the help of soldering iron. Heat applied should be such that when solder wire is touched to joint, it must melt quickly.
- + The joint and the soldering iron is held such that molten solder should flow smoothly over the joint.
- + When joint is completely covered with molten solder, the soldering iron is removed.
- + The joint is allowed to cool, without any movement.
- + The bright shining solder indicates good soldering.
- + In case of dry solder joint, a air gap remains in between the solder material and the joint. It means that soldering is improper. This is removed and again soldering is done.
- + Thus is this way all the components are soldered on P. C. B.

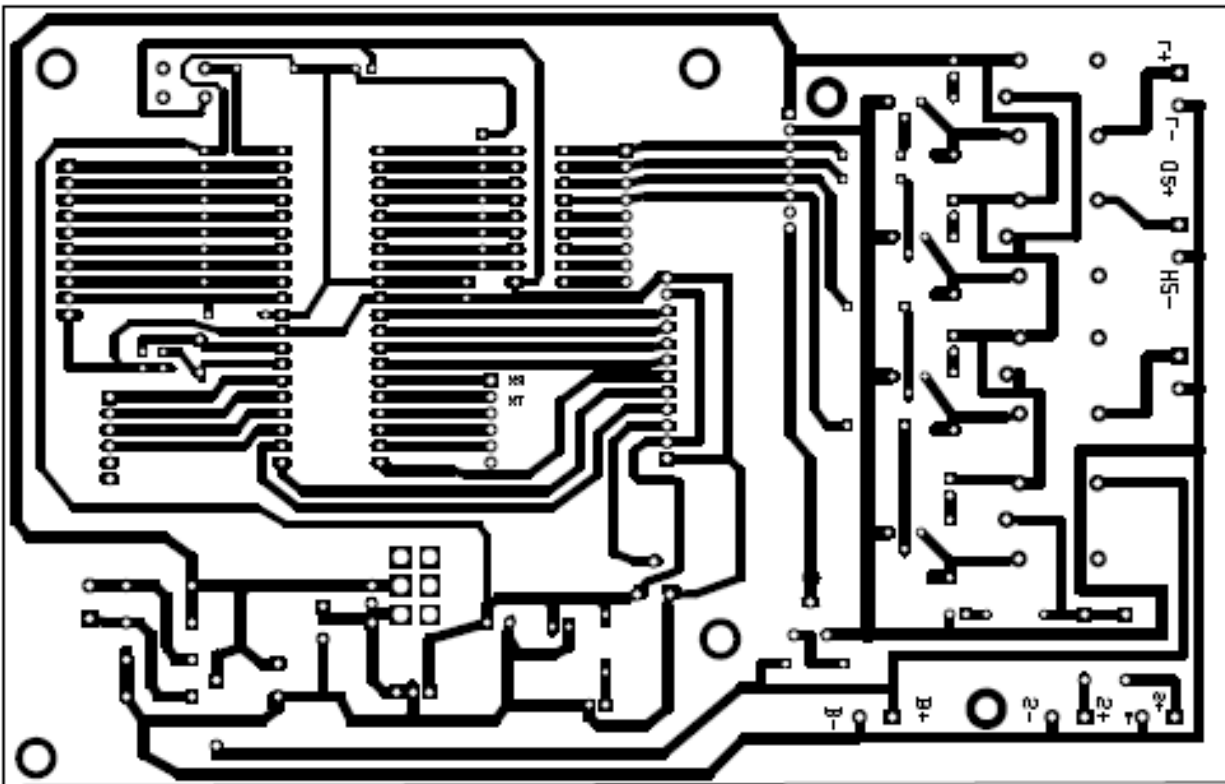

CHAPTER - 6

6. TESTING AND TROUBLESHOOTING

Before you apply power, read the instructions carefully to check you haven't missed anything, and whether there are any specific instructions for switching on and testing. Check again that you have all polarity sensitive components the right way around, and that all components are in the correct places. Check off-board components are connected correctly. Check the underside of the board carefully for short circuits between tracks - a common reason for circuits failing to work.

When you are sure everything is correct, apply power and see if the circuit behaves as expected, again following the kit manufacturers instructions.

If it works, WELL DONE! You have your first working circuit - be proud of it! Skip the rest of this page and click the right arrow at the bottom, or [here](#).

If it doesn't quite work as expected, or doesn't work at all, don't despair. The chances are the fault is quite simple. However, disconnect the power before reading on.

Check the basic's first - is the battery flat? Are you sure the 'On' switch really is on? (Don't laugh, it's easily done) If the project has other switches and controls check these are set correctly.

Next - check again all the components are in the correct place - refer to the diagram in the instructions. Look again at the underside of the board - are there any short circuits? These can be caused by almost invisible 'whiskers' of solder, so check for these with a magnifying glass in good light. Brushing the bottom of the board vigorously with a stiff brush can sometimes remove these.

Pull the components gently to see if they are all fixed into the board properly. Check the soldered joints - poor soldering is the most common cause of circuits failing to work. The joints should be shiny, and those on the circuit board should be volcano shaped with the component wire end sticking out of the top. If any look suspect then redo them. Remove the solder with a solder sucker or braid and try again.

Check for solder splashes shorting across adjacent tracks on the circuit board, especially where connections are very close such as on integrated circuits ('chips'). Solder splashes are most likely

on stripboard. You can check for shorts using a multimeter set it to it's continuity range, or low resistance range. Be aware if you do this though, that there will be a resistance between some tracks due to the components. Any resistance below 1 ohm between tracks is likely to be a solder splash. Run the soldering iron between tracks on stripboard to remove any solder bridges.

If the circuit still fails to work you will need to refer to the circuit diagram and take voltage readings from the circuit to find out what's wrong. You will need a multimeter to do this (see [tools](#)). Remember that if you find one fault such as a reversed component and correct it, it might have caused damage to other components.

(A)APPLICATIONS

1. City highway and any internal Road
2. Housing Society and Residential Buildings
3. Corporate Buildings and Office Buildings
4. School , College, Library and University Building
5. National Highway and State Highway
6. Village, Rural areas, Forest, Sea faces , Beaches and Border area
7. Hotels, Public places, Bus stop, Railway stations and Airport
8. Tourist places and Temples
9. Government Buildings etc.

(B)BENEFITS

1. Eco-Friendly.
2. Street Lighting.
3. Alternate Fuel-Hydrogen.
4. Oxygen Released in Air.
5. Electrolysis of Waste Water.
6. Conservation of Fossil Fuel.

(C)ADVANTAGES

1. It can be replace conventional tree in city arias.
2. The steady structure cannot fall like natural trees.
3. Like a natural trees it can produce the oxygen for freshening environment.
4. It create the Hydrogen Gas for fuel.
5. It can avoid water pollution by west water electrolysis.
6. It work as street light.
7. Its structure is decorative and attractive.
8. By advertisement display it will make income.
9. Its not create any type pollution.
10. Its create electricity from sun light.

(D)DISADVANTAGES

1. Implementation cost is high.
2. It required some maintenance.

CONCLUSION

By Considering latest trend in technology and society we need some alternate method to reduce the causes produce by these. Also need to create natural environment atmosphere for good and healthy life.

Research and experimentation on the concept of lighting; innovation and technology in the utilization and control of light; extreme attention to eco-compatible materials and to environmental needs in general; a deeply rooted vocation for fine design; these are the values that distinguish Arsenide and the principles that underlie this new concept of public lighting. FAUX TREE is the successful marriage of the most advanced technology and the aesthetic requirements of the urban environment by way of renewable energy.

BIBLIOGRAPHY

1. Basic Electronics – B.Ram
2. Digital Electronics – R.P.Jain
3. www.redcircuits.com
4. www.alldatasheet.com
5. www.electronicsforu.com

REFERENCE

1. <http://www.marktechopto.com>
2. <http://accept.la.asu.edu/courses/phs110/expmts/exp13a.html>
3. <http://www.kpsec.freeuk.com/components/led.html>
4. <http://www.fiber-optics.info/articles/LEDs.html>
5. <http://www.theledlight.com/technical1.html>
6. <http://hyperphysics.phy-astr.gsu.edu/hbase/electronic/leds.html>
7. www.kpsec.freeuk.com/components/led.html

