A perspective drawing of a city street. The drawing shows several multi-story buildings with windows and balconies. The street is paved and has a yellow curb on the left. The drawing is done in a sketchy style with light colors and some shading. The text "Module 2" is overlaid on the drawing.

Module 2

# PERSPECTIVE DRAWING

- Prof. Rohan Dasgupta

- **Drawing is the language Civil Engineers express their ideas in.**
- **Drawings give us detailed idea about the structure, as it will appear.**
- **According to the need or purpose, drawings can be classified as:**
  - i) Oblique Drawing**
  - ii) Isometric Drawing**
  - iii) Perspective Drawing**

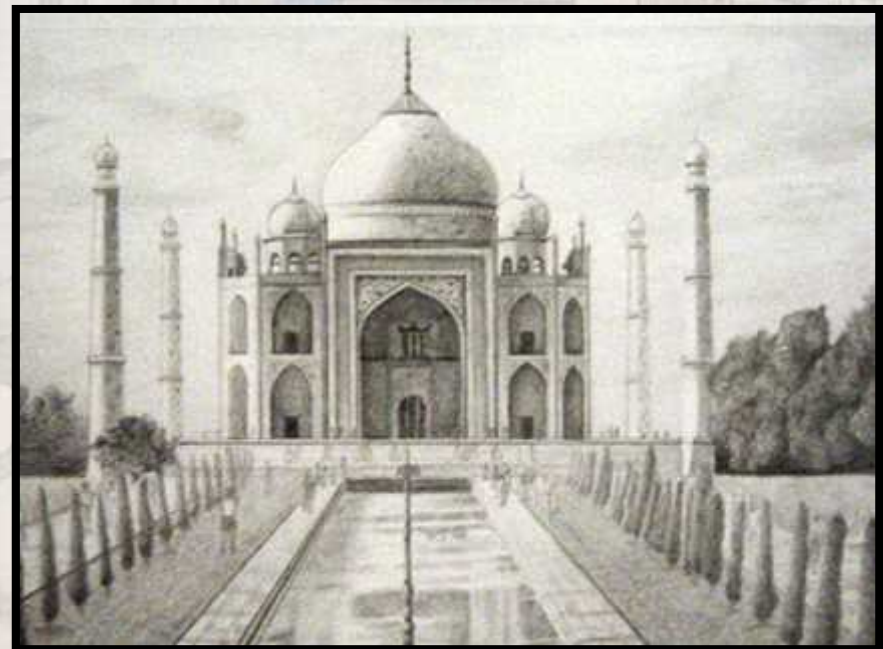

# OBLIQUE DRAWING

- The top and side view of the object is shown by projecting oblique lines from a frontal orthographic view i.e. elevation in an oblique drawing.
- Angles commonly used for oblique drawings are  $30^\circ$ ,  $45^\circ$  and  $60^\circ$ .
- If  $30^\circ$  angle is taken from horizontal axis, it gives more detailed view of one side.
- If  $45^\circ$  angle is taken from horizontal axis, it gives more clear idea about both the sides.
- If  $60^\circ$  angle is taken from horizontal axis, it gives a clear view of the top view of the structure.

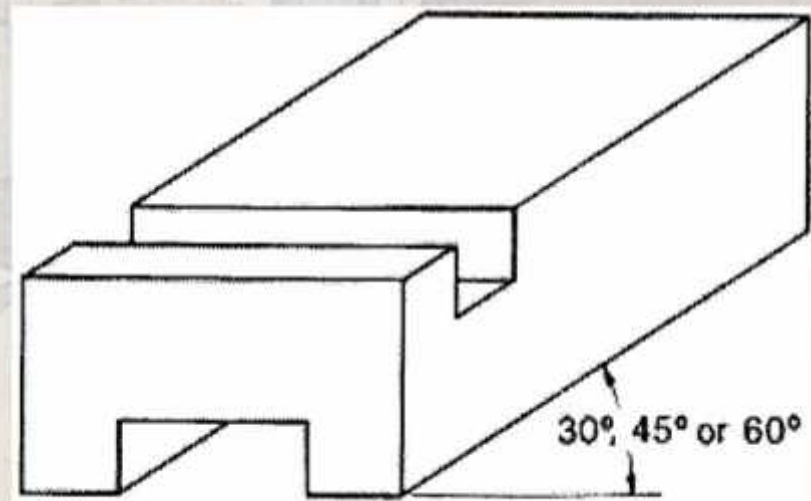

# ISOMETRIC DRAWING

- The prefix “iso” is derived from the Latin word “isos” meaning “equal”.
- To draw an isometric view, the object or structure is turned to make the 3 sides visible in such a way that they should lie on 3 equally divided axes about a centre.

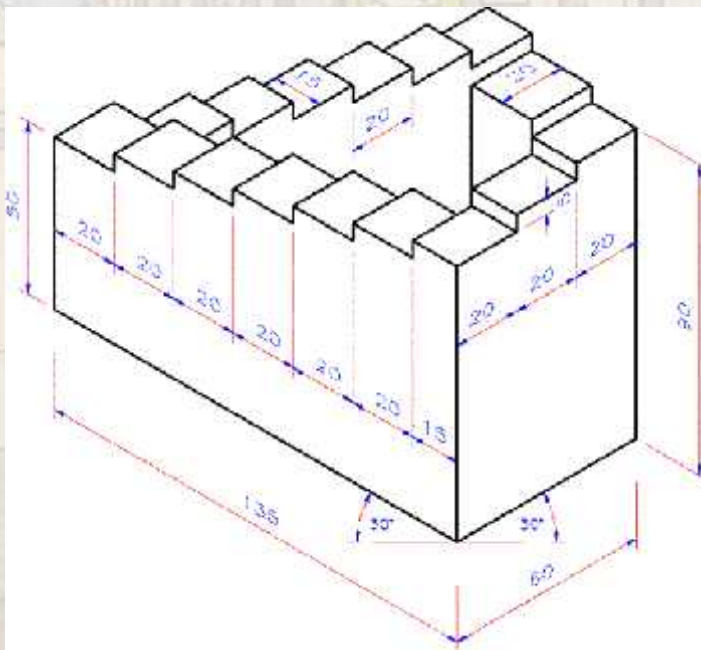

- A pleasing view is obtained by keeping one axis vertical and other two axes at 30° angle with the horizontal.

# PERSPECTIVE DRAWING

- The word “perspective” means the proper relative position of objects as seen.
- Perspective drawing is the only drawing which represents contemplated building as it would appear to a spectator.
- It is the representation of an object on a plane surface as it would appear to the eye when viewed from a fixed point.



OBLIQUE  
DRAWING

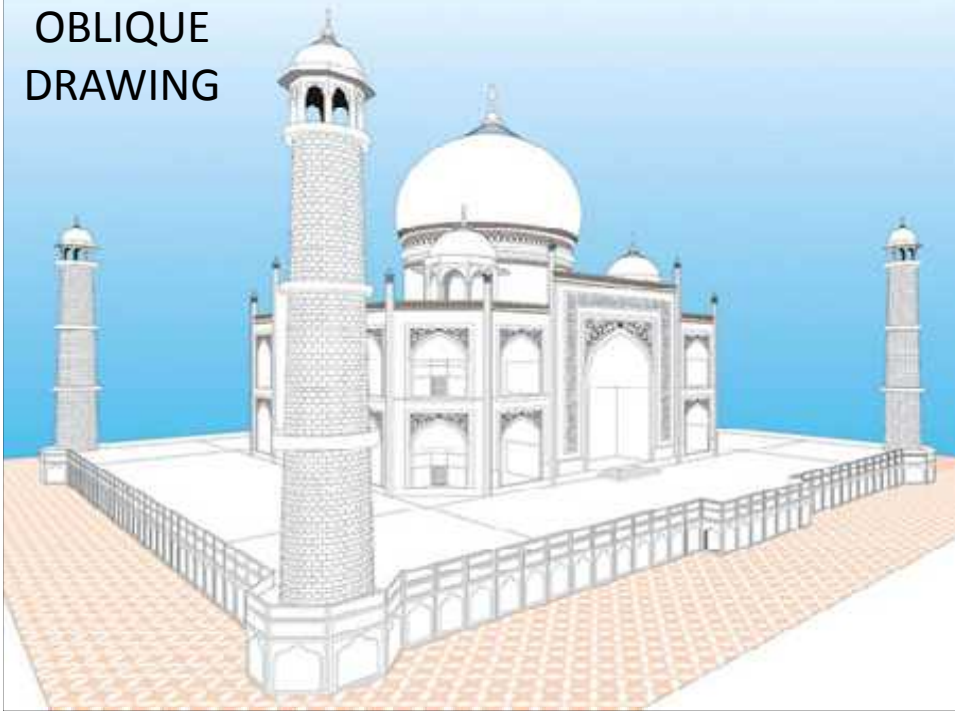

ISOMETRIC  
DRAWING

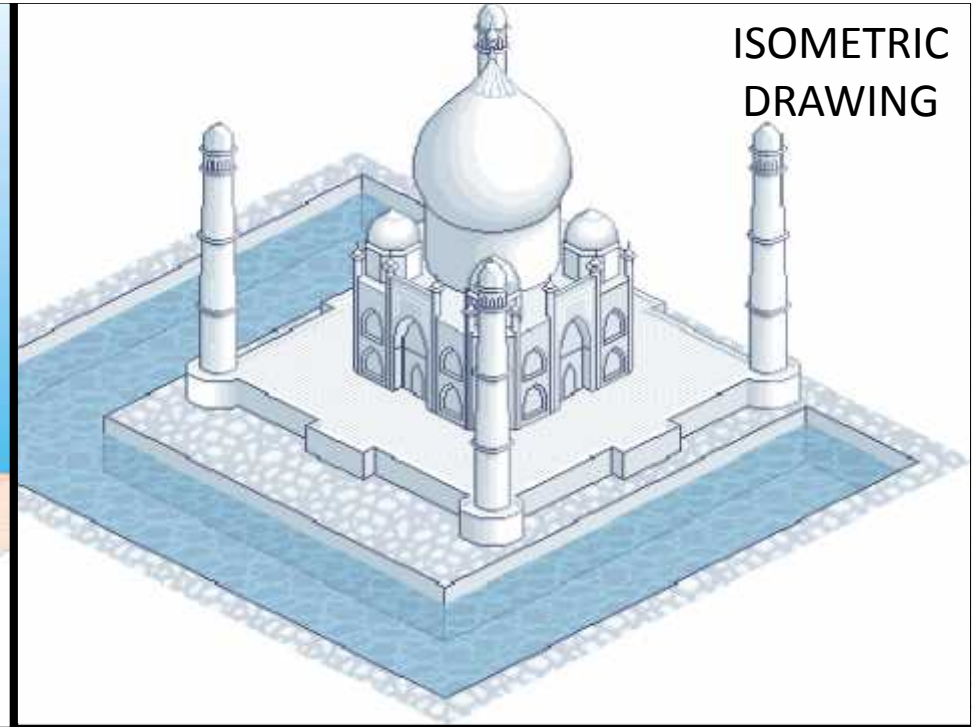

PERSPECTIVE DRAWING

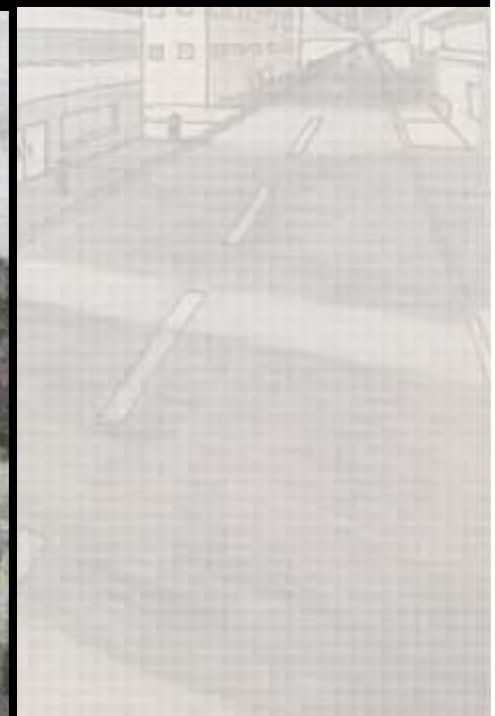
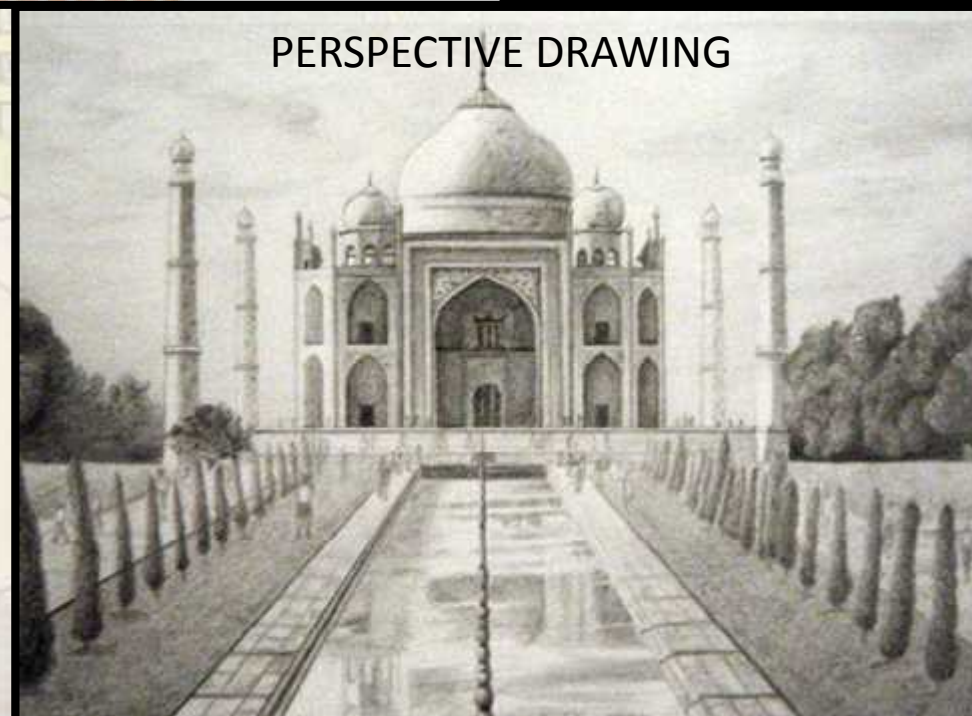
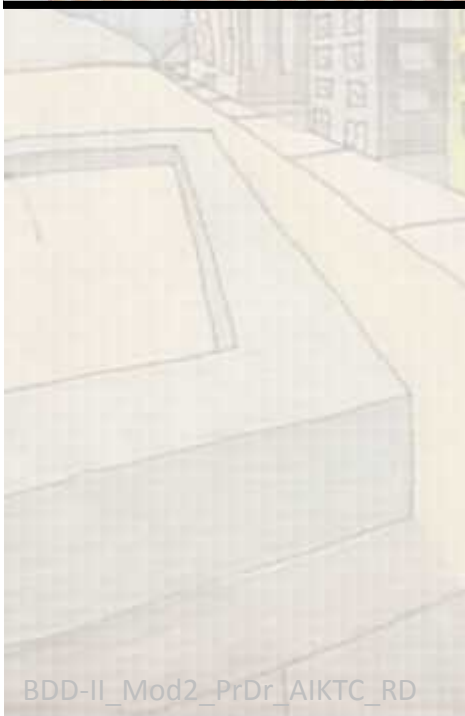

Now let's consider this box...



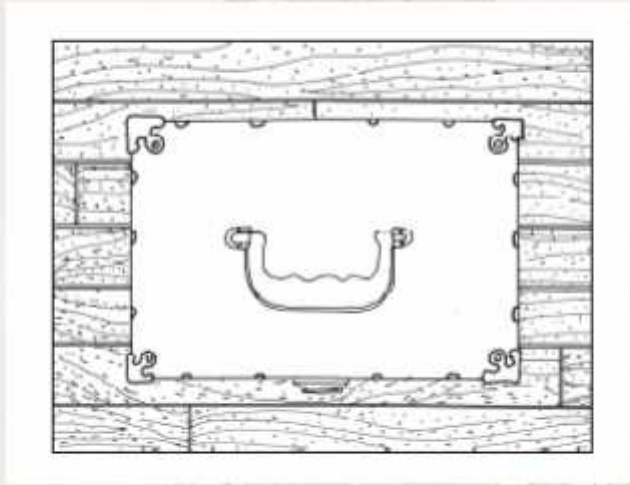

**PLAN**

- This is the **PLAN** or Top View of the box.
- You are looking directly down on the box and there is no height shown in the handle.

- This is the **ELEVATION** or Front View of the box.
- You are looking directly up on the box and there is no depth shown in the handle.

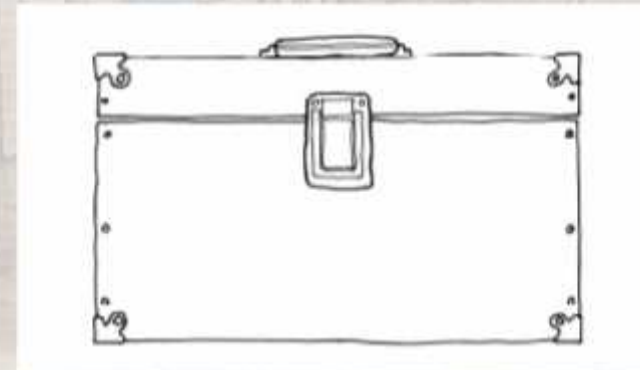

**ELEVATION**



- One point perspective provides a three-dimensional depiction of the box.
- *Notice the flat front of the box and the parallel lines forming the sides of the box recede towards a single point.*

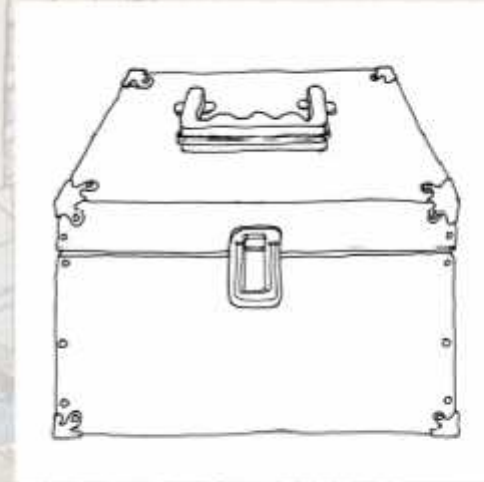

ONE-POINT PERSPECTIVE

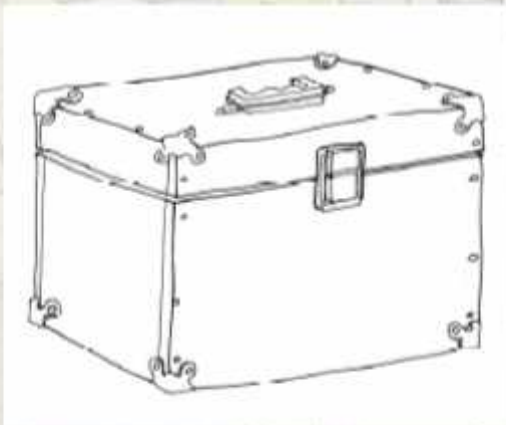

TWO-POINT PERSPECTIVE

- Two point perspective also provides a three-dimensional depiction of the box.
- *But in this view there is a leading edge and each side appears to get smaller as they move away from the leading edge.*

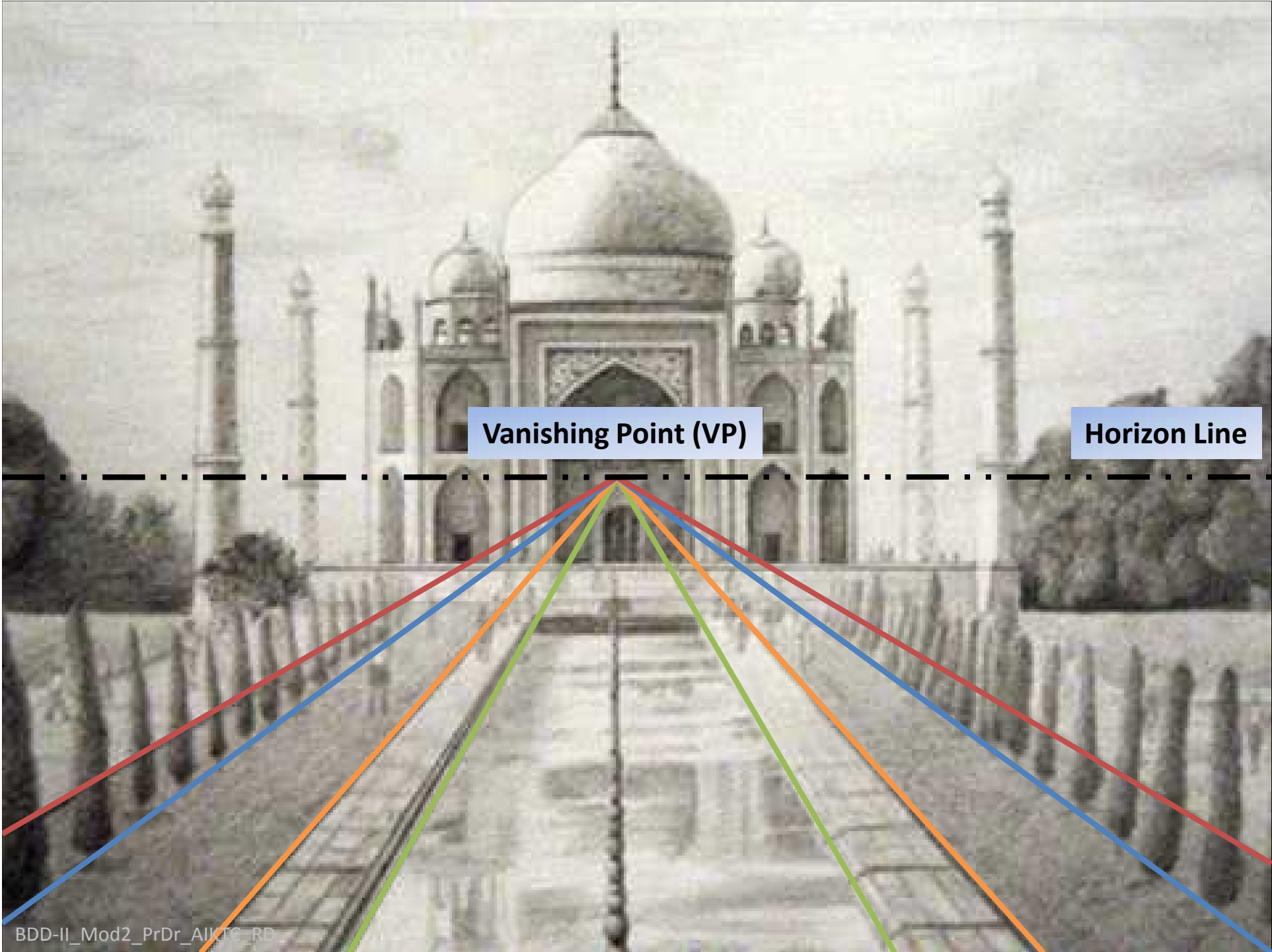

Vanishing Point (VP)

Horizon Line

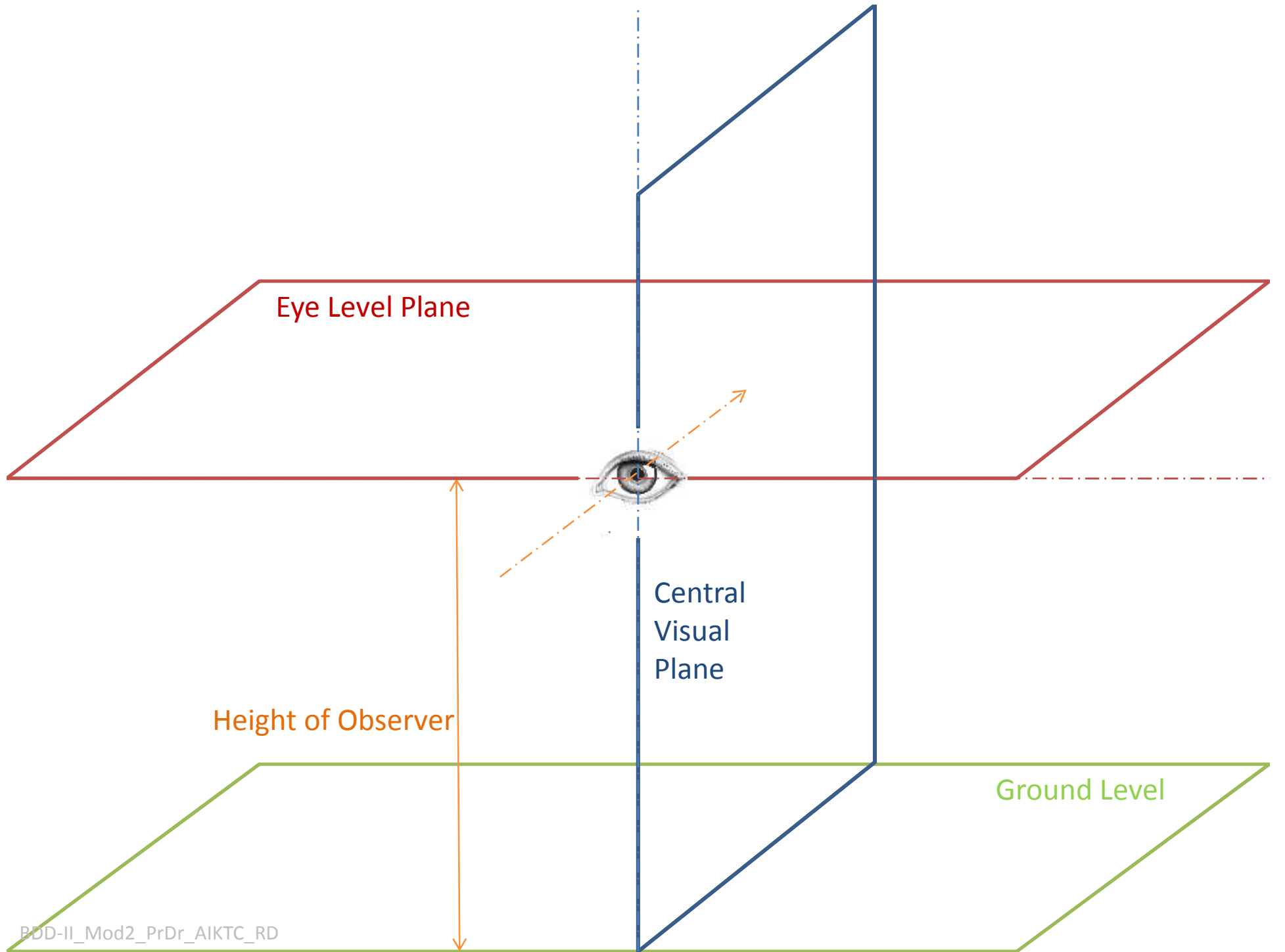

Eye Level Plane

Central  
Visual  
Plane

Height of Observer

Ground Level

Picture Plane

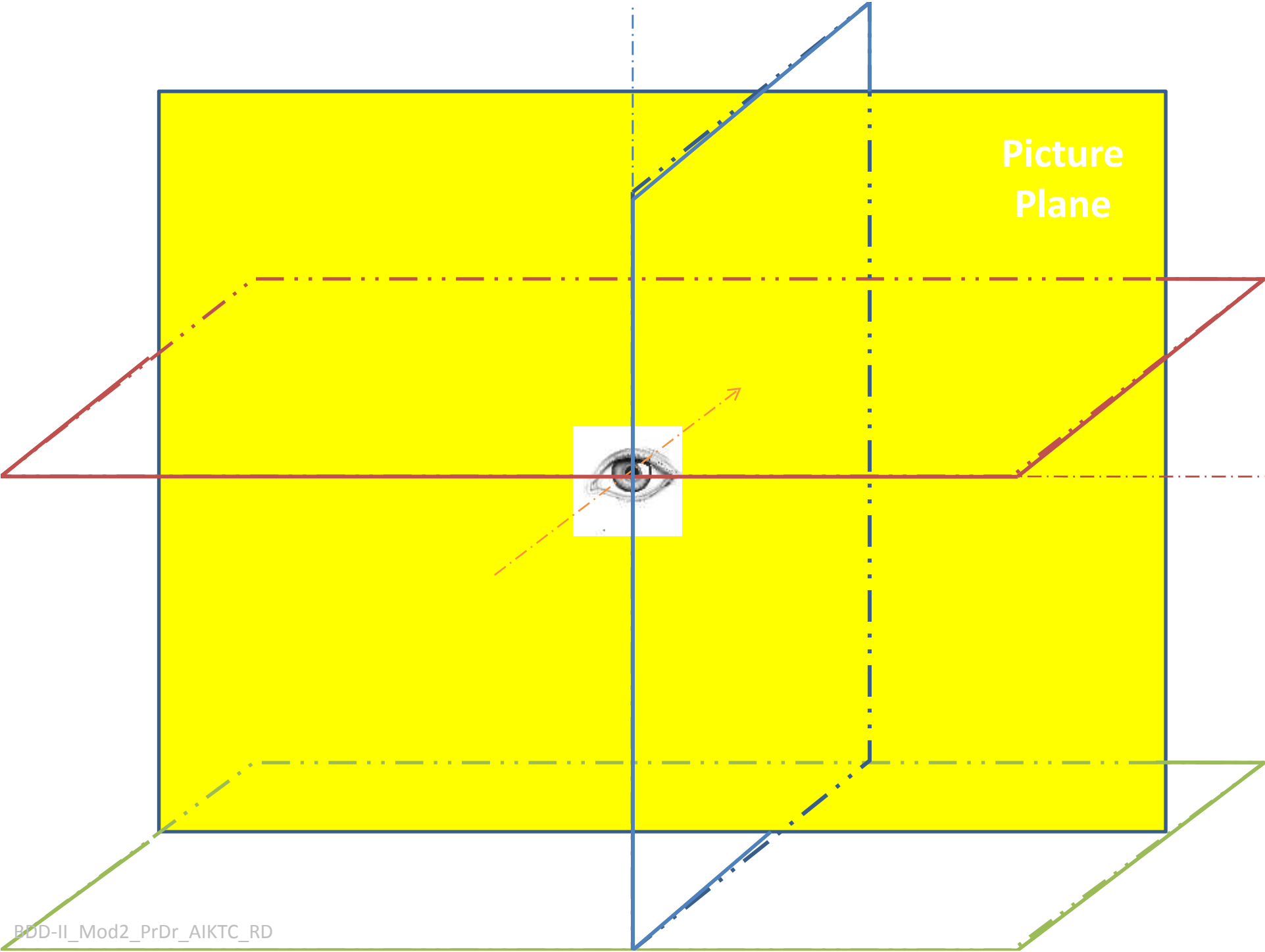
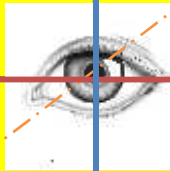

## DEFINITIONS:

- **Vanishing points (VPs):**

The imaginary point(s) in an image where parallel lines appear to converge in as they go further away from the observer, are known as vanishing points.

It coincides with the eye level of the observer.

*If an image has one vanishing point, it's known as one point perspective; if it has two it's called two point perspective.*

- **Horizon Line:**

The imaginary horizontal line passing through the VP where the sky appears to meet the ground is called as horizon line.



## DEFINITIONS:

- **Station point (SPs):**

The position of the observer in plan with respect to dimension of a structure is known as the station point (SP).

- **Eye Level Plane:**

The imaginary horizontal plane passing through the observer's eye and the horizon line and parallel to the ground level plane is known as eye level plane.

- **Central Visual Plane:**

The imaginary vertical plane passing through the observer's eye and perpendicular to the eye level plane and ground level plane is known as central visual plane.

## DEFINITIONS:

- **Picture Plane (PP):**

The imaginary plane cutting through both the eye level plane and central visual plane in a mutual perpendicular fashion, is known as the picture plane (PP).

It can be imagined as a transparent plane cutting through the path of the visual rays. It forms the focal plane onto which all the information is projected.

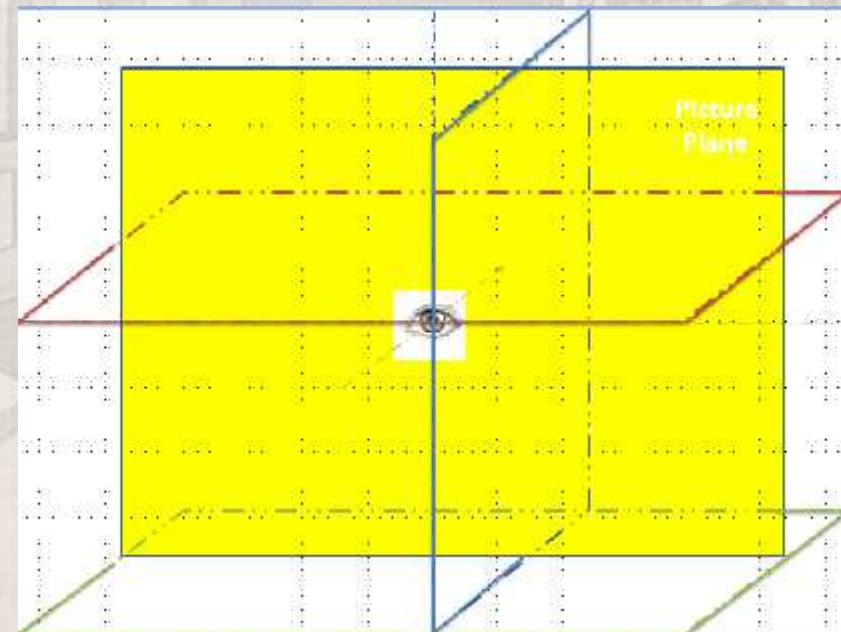



- **How to draw a one-point perspective drawing:**

- ✓ Given data:

- i) Plan of the structure
- ii) Elevation of the structure
- iii) Position of station point
- iv) Height of the observer





- **How to draw a one-point perspective drawing:**

- ✓ **Steps:**

- i) Draw the given plan on the extreme top of the drawing sheet.  
*Note: If the station point is to the left of the plan, draw the plan on the extreme top right and vice versa.*
- ii) Mark the picture plane (PP) and the station point (SP) on the plan with the help of the given data.
- iii) Draw the given elevation at the bottom of the drawing sheet.  
*Note: If the station point is to the left of the plan, draw the elevation on the bottom left and vice versa.*  
*Leave adequate distance between the station point and the elevation for a neat drawing.*



- **How to draw a one-point perspective drawing:**

- ✓ **Steps:**

iv) Draw the ground level (GL) and mark the vanishing point (VP) on the elevation with the help of the given data.

v) Draw the true shape of the face lying on the PP with the help of projections from the plan and elevation.

*Note: Straight faces only will maintain their true shapes in the perspective; inclined faces will not maintain their true shapes in the perspective.*

vi) In the plan, join points of details (wall edges, windows, doors etc) of the face NOT lying on the PP to the SP.

vii) In the elevation, join the points of details of the same face to the VP.

- **How to draw a one-point perspective drawing:**

- ✓ **Steps:**

*Note: No projections from the true shape face can be directly joined to the VP. Projections must be first transferred to the edge of the tapering face and then joined to the VP.*

*Similarly, inclined edges on the true faces are also to be first projected on to the edge of the tapering end and then joined to the VP.*

viii) To get the details of the tapering end in perspective, draw projections of the same from the lines joining the SP at the point where they're cutting the PP.

ix) Join the details on the tapering face to complete the one point perspective drawing.



- **How to draw a two-point perspective drawing:**

- ✓ **Steps:**

- i) Draw the inclined given plan at the top centre of the drawing sheet with an edge leading.

- Note: If angle of inclination is not given, take 30 degrees for longer side and 60 degrees for shorter side.*

- ii) Draw the picture plane (PP) and the station point (SP) on the plan with the help of the given data.

- iii) Mark the ground level (GL) at a suitable place at the bottom of the sheet and draw the horizon line (HL) at a length equal to the height of the observer.

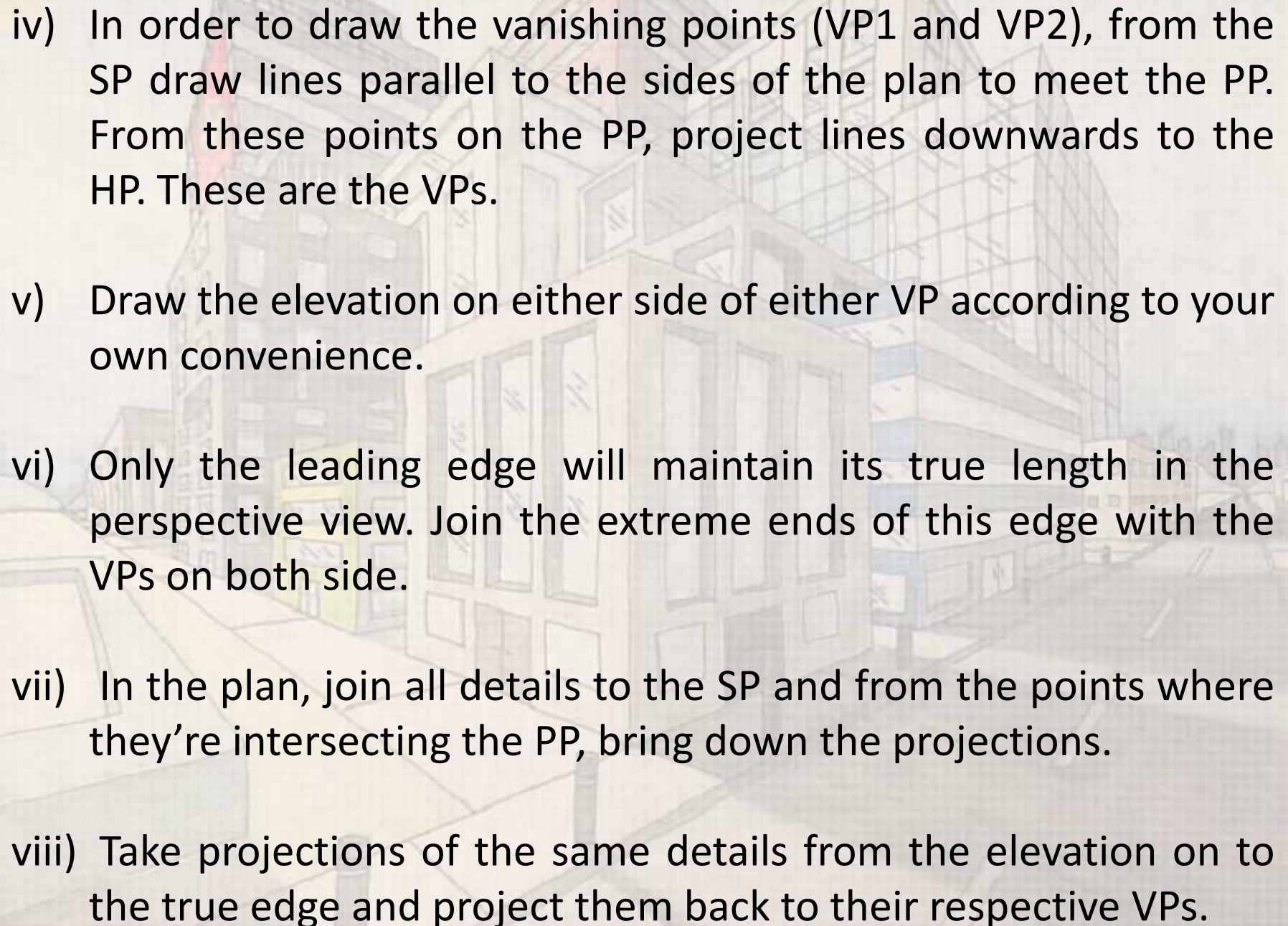
- 
- iv) In order to draw the vanishing points (VP1 and VP2), from the SP draw lines parallel to the sides of the plan to meet the PP. From these points on the PP, project lines downwards to the HP. These are the VPs.
  - v) Draw the elevation on either side of either VP according to your own convenience.
  - vi) Only the leading edge will maintain its true length in the perspective view. Join the extreme ends of this edge with the VPs on both side.
  - vii) In the plan, join all details to the SP and from the points where they're intersecting the PP, bring down the projections.
  - viii) Take projections of the same details from the elevation on to the true edge and project them back to their respective VPs.

ix) Join the details on the tapering face to complete the one point perspective drawing.

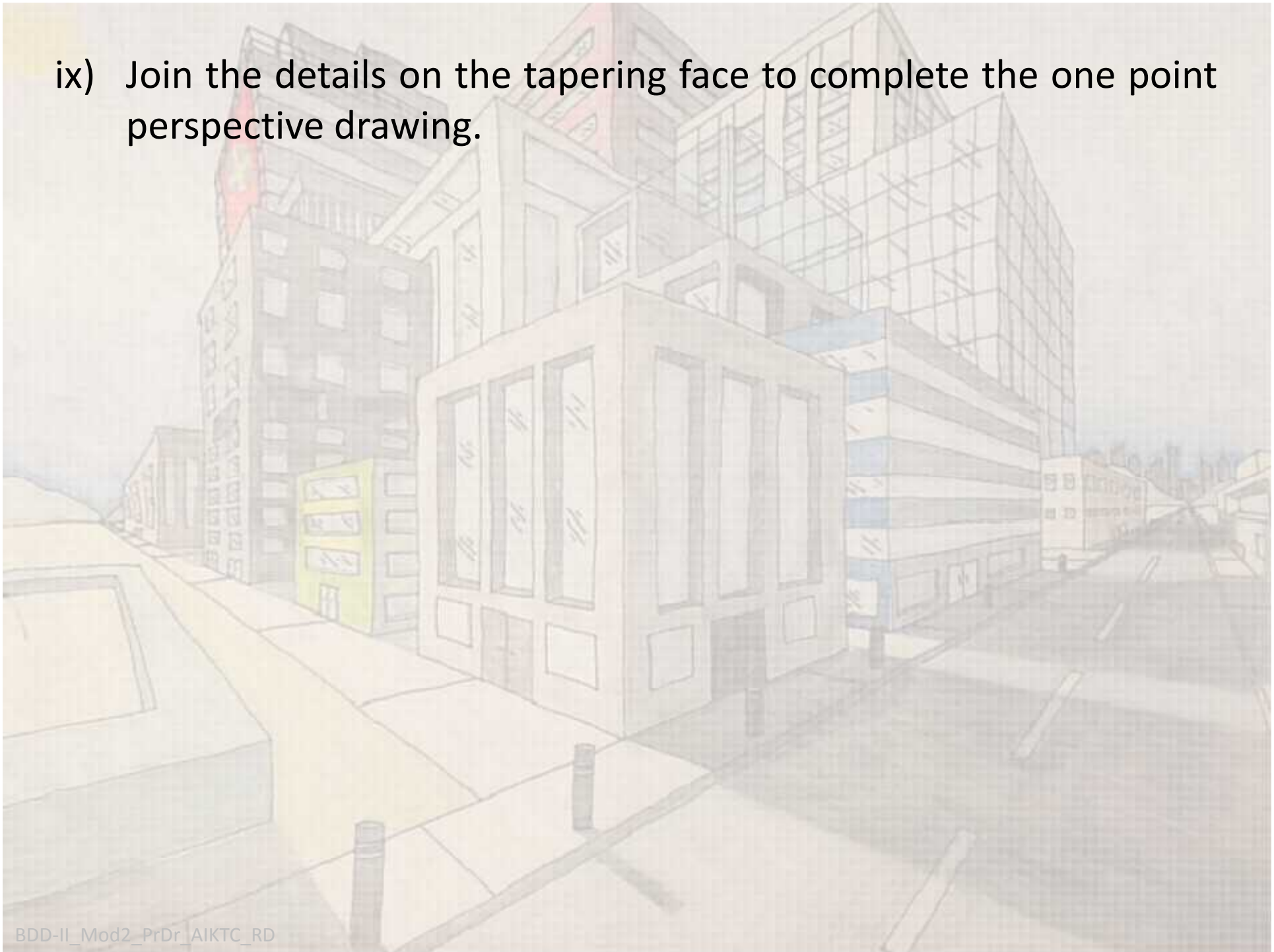

A stylized, sketchy illustration of a city street scene. The drawing uses light, muted colors and fine lines to create a sense of depth and perspective. In the foreground, a sidewalk leads towards a street with a yellow bus. Buildings of various heights and styles line the street, with some featuring balconies and windows. The overall atmosphere is soft and artistic.

*Thank you!*