

93

[Time: Three Hours]

[Marks:80]

Please check whether you have got the right question paper.

- N.B:
1. Question.No.1 is compulsory.
 2. Answer any three questions from remaining.

- Q.1 a) Prove that $\tanh^{-1}(\sin\theta) = \cosh^{-1}(\sec\theta)$ 03
- b) Prove that the matrix $\frac{1}{\sqrt{3}} \begin{bmatrix} 1 & 1+i \\ 1-i & -1 \end{bmatrix}$ is unitary 03
- c) If $x = uv$ & $y = u/v$ prove that $JJ^1 = 1$ 03
- d) If $Z = \tan^{-1}(\frac{x}{y})$ where $x = 2t, y = 1-t^2$, prove that $\frac{dz}{dt} = \frac{2}{1+t^2}$ 03
- e) Find the n^{th} derivative of $(\cos 5x \cdot \cos 3x \cdot \cos x)$ 04
- f) Evaluate $\lim_{x \rightarrow 0} (x)^{\frac{1}{1-x}}$ 04
- Q.2 a) Find all values of $(1+i)^{\frac{1}{3}}$ & show that their continued product is $(1+i)$ 06
- b) Find non-singular matrices P&Q such that PAQ is in normal form where

$$A = \begin{bmatrix} 2 & -2 & 3 \\ 3 & -1 & 2 \\ 1 & 2 & -1 \end{bmatrix}$$
 06
- c) Find the maximum & minimum values of $f(x,y) = x^3 + 3xy^2 - 15x^2 - 15y^2 + 72x$ 08
- Q.3 a) If $u = f(\frac{y-x}{xy}, \frac{z-x}{xz})$, show that 06

$$x^2 \frac{\partial u}{\partial z} + y^2 \frac{\partial u}{\partial y} + z^2 \frac{\partial u}{\partial x} = 0$$
- b) Using encoding matrix $\begin{bmatrix} 1 & 1 \\ 0 & 1 \end{bmatrix}$, encode & decode the message 'MUMBAI'. 06
- c) Prove that $\log [\tan (\frac{\pi}{4} + \frac{ix}{2})] = i \tan^{-1}(\sinh x)$ 08
- Q.4 a) Obtain $\tan 5\theta$ in terms of $\tan \theta$ & show that $1 - 10 \tan^2 \frac{\pi}{10} + 5 \tan^4 \frac{\pi}{10} = 0$ 06
- b) If $y = e^{\tan^{-1}x}$, prove that 06

$$(1+x^2)y_{n+2} + [2(n+1)x-1] y_{n+2} + n(n+1)y_n = 0$$
- c) i. Express $(2x^3 + 3x^2 - 8x + 7)$ in terms of $(x-2)$ using Taylor's theorem. 04
 ii. Prove that $\tan^{-1}x = x - \frac{x^3}{3} + \frac{x^5}{5} - \frac{x^7}{7} + \dots$ 04

TURN OVER

Q.5 a) If $z = x^2 \tan^{-1} \left(\frac{y}{x}\right) - y^2 \tan^{-1} \left(\frac{x}{y}\right)$

06

Prove that $\frac{\partial^2 z}{\partial y \partial x} = \frac{x^2 - y^2}{x^2 + y^2}$

b)

Investigate for what values of λ & μ the equations, $2x + 3y + 5z = 9$
 $7x + 3y - 2z = 8$
 $2x + 3y + \lambda z = \mu$

06

Have 1) no solution

2) a unique solution

3) an infinite no. of solutions

c) Using Newton Raphson method, find approximate root of $x^3 - 2x - 5 = 0$ (correct to three places of decimals.)

08

Q.6 a) Find $\tanh x$ if $5 \sinh x - \cosh x = 5$

06

b) If $u = \sin^{-1} \left(\frac{x+y}{\sqrt{x} + \sqrt{y}}\right)$ prove that

06

i. $xu_x + yu_y = \frac{1}{2} \tan u$

ii. $x^2 u_{xx} + 2xy u_{xy} + y^2 u_{yy} = \frac{-\sin u \cos 2u}{4 \cos^3 u}$

c) Solve the following systems of equations by Gauss-seidel method,

08

$$20x + y - 2z = 17$$

$$3x + 20y - z = -18$$

$$2x - 3y + 20z = 25$$

[Time : 2 Hours]

[Total Marks : 60

Please check whether you have got the right question paper.

- N.B:
1. Questions No.1 is compulsory.
 2. Attempt any three from Q.No.2 to Q.No.6.
 3. Assume any data wherever required.
 4. Figures to the right indicate marks.

1. Solve any five of the following : 15
 - (a) Draw the unit cell of HCP structure and work out the no. of atoms per unit cell.
 - (b) The mobility of holes is $0.025 \text{ m}^2/\text{V}\cdot\text{sec}$. What would be the resistivity of n-type Si if the Hall coefficient of the sample is $2.25 \times 10^{-5} \text{ m}^3/\text{C}$.
 - (c) What is the principle of solar cell? Write its advantages and disadvantages.
 - (d) An electron is confined in a box of dimension 1 \AA . Calculate minimum uncertainty in its velocity.
 - (e) Explain the factors on which reverberation time depends.
 - (f) Explain cavitation effect.
 - (g) What is Maglev? How it can have very high speed?

2. (a) Draw the following : $(1 \bar{1} 3)$, $(200) [0 0 \bar{1}]$. 8
 An electron is accelerated through 1200 volts and is reflected from a crystal. The second order reflection occurs when glancing angle is 60° . Calculate the inter planar spacing of the crystal.

- (b) Explain the concept of Fermi level. Prove that the Fermi level exactly at the centre of the Forbidden energy gap in intrinsic semiconductor. 7

3. (a) Find the following parameters for DC (Diamond Cubic) structure : 8
 - i) No. of atoms per unit cell
 - ii) Co-ordination No.
 - iii) Nearest atomic distance
 - iv) Atomic radius
 - v) APF

- (b) Define drift current, diffusion current and P - N junction. The electrical conductivity of a pure silicon at room temperature is $4 \times 10^{-4} \text{ mho/m}$. If the mobility of electron is $0.14 \text{ m}^2/\text{V}\cdot\text{S}$ and that of hole is $0.04 \text{ m}^2/\text{V}\cdot\text{S}$. Calculate the intrinsic carrier density. 7

TURN OVER

4. (a) Distinguish between Type I & Type II superconductors. 5
- (b) A classroom has dimensions $10 \times 8 \times 6 \text{ m}^3$. The reverberation time is 3 sec. 5
Calculate the total absorption of surface and average absorption.
- (c) Explain the principle, construction and working of a Magnetostriction Oscillator. 5
5. (a) Write Fermi Dirac distribution function. With the help of diagram, explain the 5
variation of Fermi level with temperature in n-type semiconductor.
- (b) Derive Schrodinger's time dependent wave equation for matter waves. 5
- (c) Find the depth of sea water from a ship on the sea surface if the time interval of 5
two seconds is required to receive the signal back. Given that : temperature of sea
water is 20°C , salinity of sea water is 10gm/lit.
6. (a) Define the term critical temperature. Show that in the superconducting state the 5
material is perfectly diamagnetic.
- (b) In a solid the energy level is lying 0.012eV below Fermi level. What is the 5
probability of this level not being occupied by an electron?
- (c) What is the wavelength of a beam of neutron having : 5
- i) an energy of 0.025eV?
- ii) an electron and photon each have wavelength of 2Å . What are their
momentum and energy? $m_n = 1.676 \times 10^{-27}\text{kg}$, $h = 6.625 \times 10^{-34} \text{ J-sec}$.
-

84

FE - sem - I - Choice based
Grading system

2/6/17

T0131 / T1870 APPLIED CHEMISTRY I.

Q.P. Code :09795

[Time: 2 Hours]

[Marks:60]

Please check whether you have got the right question paper.

- N.B:
1. Question No. 1 is compulsory.
 2. Attempt any three questions from the remaining questions.
 3. All questions carry equal marks
 4. Atomic weights:
[Ca= 40, C=12, O=16, H=1, Mg= 24, S=32, Cl= 35.5]

- Q.1 Attempt any five of the following:- 15
- a. What are cation and anion exchangers?
 - b. Give the preparation, properties and uses of polymethyl metha acrylate polymer
 - c. A 10ml of sample of waste water was refluxed with 20ml of potassium dichromate solution and after refluxing the excess unreacted dichromate required 36.2 ml of 0.1M FAS solution. A blank of 10ml of distilled water on refluxing with 20ml of dichromate solution required 46ml of 0.1 M FAS solution Calculate the COD Value of the waste water.
 - d. Define
 - (i) Flash point
 - (ii) Oilness
 - (iii) Pour point
 - e. What is Reduced phase rule?
 - f. What are the drawbacks of natural Rubber?
 - g. Explain CVD (chemical vapour deposition) method for production of CNT'S (carbon nano tubes)
- Q.2 a. Calculate the amount of lime (80% pure) and soda (90%) required for softening of 50,000 litres of hard water whose chemical analysis results are given below: 06
Ca (HCO₃)₂= 40.5 mg/L, Mg (HCO₃)₂ = 73.0mg/L, MgSO₄= 60.0 mg/L, CaSO₄ = 34.0 mg/L, CaCl₂ = 27.5 mg/L and NaCl= 20.0 mg/L
- b. (i) Write a brief note on conducting polymers 3
(ii) Mention the conditions under which semi-solid lubricants can be used 2
 - c. Explain with the help of chemical reactions 'setting and hardening 'process of cement. 4
- Q.3 a. Write a short note on: 6
- (i) Injection moulding method for plastics.
 - (ii) Polymer in medicine and surgery.
- b. (i) Draw and explain the important features of phase diagram of water system. 3
(ii) Mention the Raw materials of Portland cement along with their percentage composition 2
 - c. Ten thousand liters of hard water was made soft with zeolite. The exhausted zeolite required a total amount of 8 litres of NaCl solution containing 150 gm per litre for regeneration. Calculate the hardness of water. 4

Q.P. Code :09795

- Q.4 a. Explain Ion- Exchange process for softening of hard water. What are it's advantages and dis-advantages. 6
b. (i) 9ml of oil is taken from machine and it requires 1.5 ml of 0.04 N KOH. Find acid value. 3
(density of oil= 0.81g/ml)
(ii) Write a note on Deccay of concrete. 2
c. What are the additives mixed with plastics for its compounding? Explain their functions. 4
- Q.5 a. (i) Distinguish between Thermo- plastic and Thermosetting plastic. 6
(ii) Write a note on Visco- elastic state.
b. (i) Write a note on Ultra-filtration method for purification of water 3
(ii) Give the important functions of Lubricant. 2
c. What is the mathematical form of the Gibb's phase rule equation? Explain the meaning of each one of 4
the terms involved in it.
- Q.6 a. What is Lubrication? Explain the mechanism of fluid film Lubrication 6
b. (i) What is meant by Triple point? Apply phase rule and find degree of freedom for Triple point. 3
(ii) Distinguish between temporary and permanent hardness of water. 2
c. Describe the wet process for manufacture of Portland cement. 4
-

153

22/5/17

Q.P. Code : 017104

[Time: 3 Hours]

[Total Marks: 80]

Please check whether you have got the right question paper.

- N.B:
- 1) Question No. 1 is **compulsory**
 - 2) Attempt **any 3** questions from **remaining five** questions
 - 3) Assume suitable data if necessary and mention the same clearly
 - 4) Take $g = 9.81 \text{ m/s}^2$, unless otherwise specified.

Q. 1 a) In the rocket arm shown in fig the moment of 'F' about 'O' balances that 'P' = 250 N find 'F'. 04

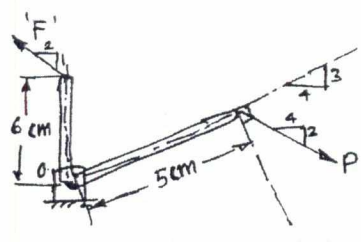

- b) State Lami's theorem. State the necessary condⁿ for application of Lami's theorem. 04
- c) A homogeneous cylinder 3m diameter and weighting 400N is resting on two rough inclined surface's shown. If the angle of friction is 15° find couple 'C' applied to the cylinder that will start it rotating clockwise. 04

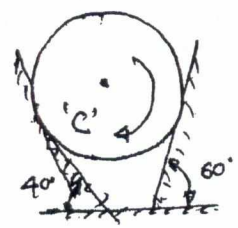

d) From (v-t) diagram find (i) distance travelled in 10 sec. (ii) total distance travelled in 50 sec. 04
(iii) Retardation.

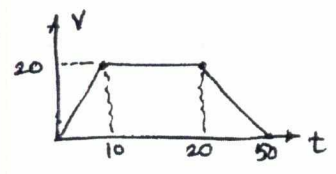

e) Blocks P₁ and P₂ are connected by inextensible string. Find velocity of block P₁, if it falls by 0.6m starting from rest. The coefficient of friction is 0.2, pulley is friction less. 04

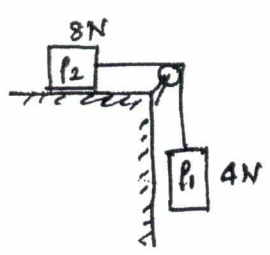

TURN OVER

Q. 2 a) Compute the resultant of the three forces acting on the plate shown in fig. Locate its intersection with AB and BC. 06

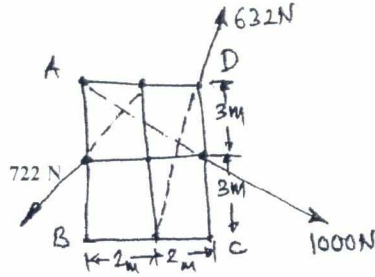

b) Two cylinders 1 and 2 are connected by a rigid bar of negligible weight hinged to each cylinder and left to rest in equilibrium in the position shown under the application of force 'P' applied at the center of cylinder 2. Determine the magnitude of force 'P'. If the weights of the cylinders 1 and 2 are 100N and 50N respectively. 08

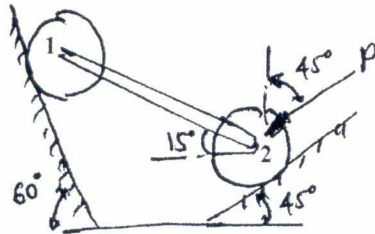

c) Just before they collide, two disk on a horizontal surface have velocities shown in fig. Knowing that 90N disk 'A' rebounds to the left with a velocity of 1.8 m/s. Determine the rebound velocity of the 135 N. disk 'B' Assume the Impact is perfectly elastic. 06

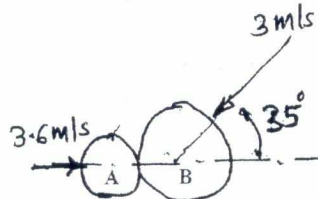

Q. 3 a) Find the centroid of the shaded portion of the plate shown in the fig. 08

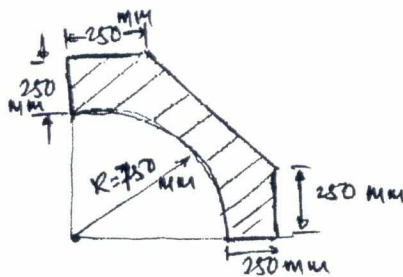

TURN OVER

3

- b) Co-ordinate distance are in 'm' units for the space frame in fig. there are 3 members. AB, AC and AD. There is a force W-10 KN acting at A in a vertically upward direction. Determine the tension in AB, AC and AD. 06

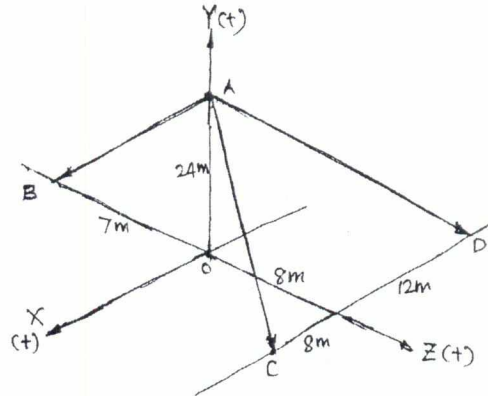

- c) A 50N collar slides without friction along a smooth rod which is kept inclined at 60° to the horizontal. The spring attached to the collar and the support 'C'. The spring is unstretched when the collar is at 'A' (AC is horizontal) Determine the value of spring constant 'K' given that the collar has a velocity of 2.5 m/s when it has moved 0.5m along the rod as shown in fig. 06

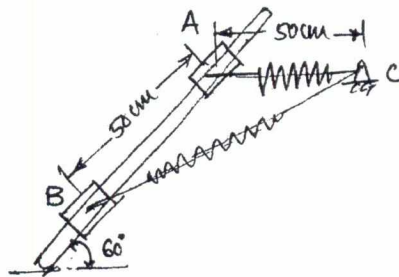

- Q. 4 a) A boom AB is supported as shown in fig by a cable runs from 'C' over a small smooth pulley at D. Compute the tension T in cable and reaction at A. Neglect the wt of the boom and size of the pulley. 08

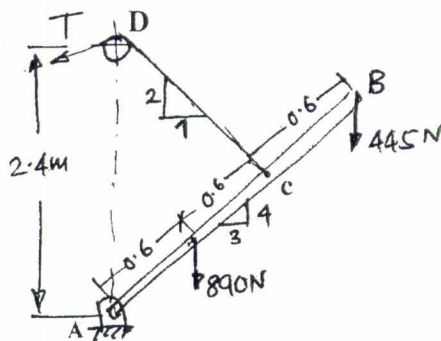

TURN OVER

- b) The accelⁿ of the train starting from rest at any instant is given by the expression $a = \frac{8}{(v^2 + 1)}$ 06
 where V is the velocity of train in m/s. Find the velocity of the train when its displacement is 20m and its displacement when velocity is 64.8 kmph.
- c) Angular velocity of connector BC is 4 r/s in clockwise direction. What are the angular velocities of cranks AB and CD. 06

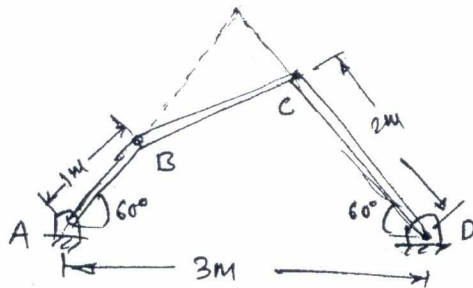

- Q.5 a) In the truss shown in fig. compute the forces in each member. 08

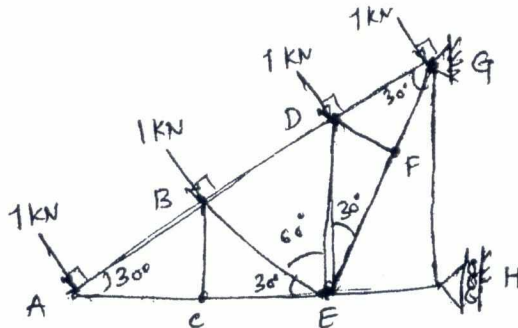

- b) Determine the speed at which the basket ball at 'A' must be thrown at an angle of 30° so that it makes it to the basket at B. Also find at what speed it passes through the hoop. 06

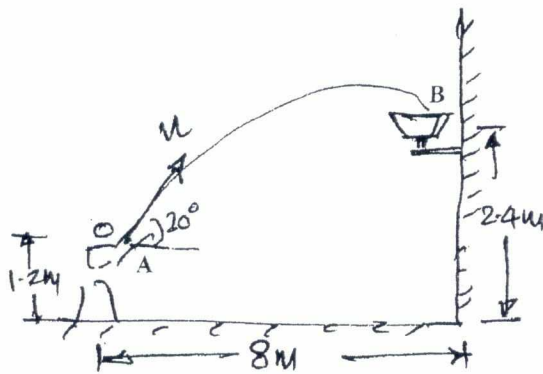

TURN OVER

- c) Fig shows a collar B which moves upwards with constant velocity of 1.5 m/s At the instant when $\theta = 50^\circ$ determine (i) The Angular velocity of rod pinned at B and freely resting at A against 25° sloping ground and (ii) The velocity of end A of the rod. 06

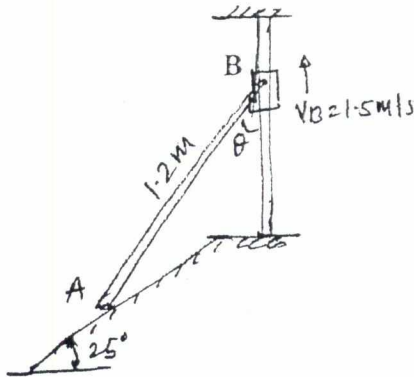

- Q. 6 a) A force of 140KN passes through point C (-6,2,2) and goes to point B (6,6,8) calculate moment of force about origin. 04
- b) Ref to fig. If the coeff. of friction is 0.60 for all contact surfaces and $\theta = 30^\circ$, what force 'P' applied to the block 'B' acting down and parallel to the incline will start motion and what will be the tension in the cord parallel to inclined plane attached to 'A'. Take $W_A = 120N$ and $W_B = 200N$. 08

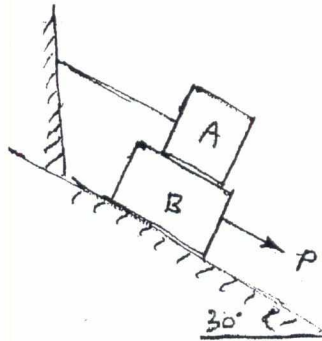

- c) Determine the required stiffness 'K' so that the uniform 7Kg bar AC is in equilibrium when $\theta = 30^\circ$ Due to the collar guide at B the spring remains vertical and is unstretched when $\theta = 0$ Use Principle of Virtual Work. 04

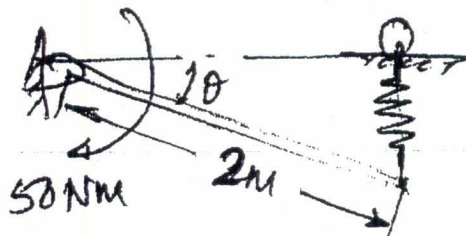

TURN OVER

- d) The system shown in fig is initially at rest. Neglecting friction determine the force 'P' required 04 if the velocity of the collar B is 5 m/s after 2 sec and corresponding tension in the cable.

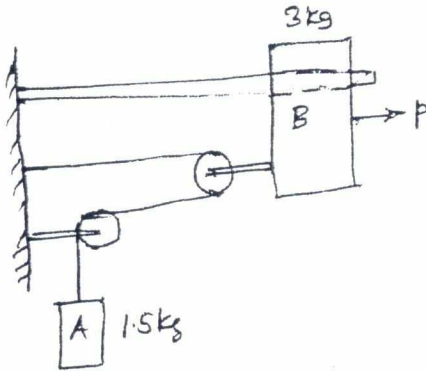

Time: 3 hours

Total Marks: 80

1. Question No. 1 is compulsory
2. Attempt any three questions from the remaining five
3. Figures to the right indicate full marks
4. Wherever not mentioned value of resistance is in ohms
5. Assume suitable data if necessary

- Q1. a) Find the ratio V_L/V_S in the circuit shown below using Kirchoff's laws. 4

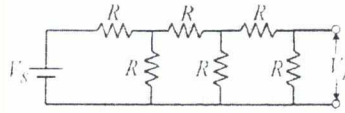

- b) Find the rms value for the following waveform. 4

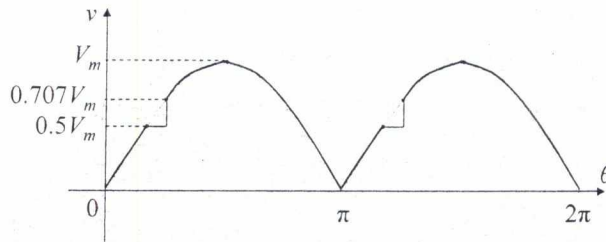

- c) Draw the phasor diagram for a three phase star connected load with leading power factor. Indicate all the line and phase voltages and currents. 4
- d) A 5 kVA, 240/2400 V, 50 Hz single phase transformer has the maximum value of flux density as 1 Tesla. If the emf per turn is 10. Calculate the number of primary & secondary turns and the full load primary and secondary currents. 4
- e) Explain the principle of operation of DC generator. 4
- Q2. a) Find the current through 3 Ω resistor by mesh analysis. 4

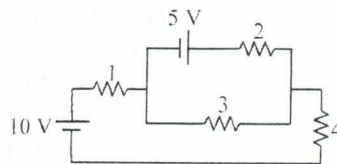

- b) Find the current delivered by the source. 8

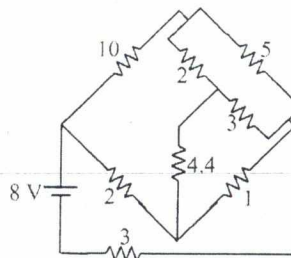

- c) The voltage and current in a circuit are given by $\bar{V} = 12 \angle 30^\circ$ V and $\bar{I} = 3 \angle 60^\circ$ A. The frequency of the supply is 50 Hz. Find 8
- Equation for voltage and current in both the rectangular and standard form.
 - Impedance, reactance and resistance,
 - phase difference, power factor and power loss.
- Draw the circuit diagram considering a simple series circuit of two elements indicating their values.

- Q3. a) Find the resultant voltage and its equation for the given voltages which are connected in series. 4

$$e_1 = 2 \sin \omega t, e_2 = -\cos \left(\omega t - \frac{\pi}{6} \right), e_3 = 2 \cos \left(\omega t - \frac{\pi}{4} \right), e_4 = -2 \sin \left(\omega t + \frac{\pi}{3} \right).$$

- b) Find the current through 20 Ω resistor by using superposition theorem. 8

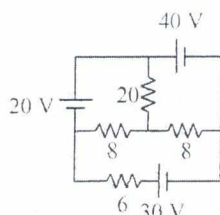

- c) Two parallel branches of a circuit comprise respectively of i) a coil having 5 Ω resistance and inductance of 0.05 H, ii) a capacitor of capacitance 100 μ F in series with a resistance of 10 Ω . The circuit is connected to a 100 V, 50 Hz supply. Find 8
- impedance and admittance of each branch,
 - equivalent admittance and impedance of the circuit,
 - the supply current and power factor of the circuit.
- Draw its equivalent series circuit using two elements indicating their values.

- Q4. a) How are DC machines classified? 4

- b) Find the current through 10 Ω resistor by using Norton's theorem. 8

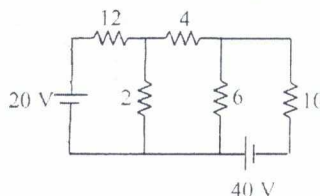

- c) An inductive coil has a resistance of 20 Ω and inductance of 0.2 H. It is connected in parallel with a capacitor of 20 μ F. This combination is connected across a 230 V supply having variable frequency. Find the frequency at which the total current drawn from the supply is in phase with the supply voltage. What is this condition called? Find the values of total current drawn and the impedance of the circuit at this frequency. Draw the phasor diagram and indicate the various currents & voltages in the circuit. 8

- Q5. a) A coil having a resistance of 20Ω and inductance of 0.2 H is connected across a 230 V 50 Hz supply. Calculate 4
- circuit current
 - phase angle
 - power factor
 - power consumed
- b) A balanced three phase delta connected load draws a power of 10 kW , with a power factor of 0.6 leading when supplied with an ac supply of 440 V , 50 Hz . Find the circuit elements of the load per phase assuming a simple series circuit of two elements. 8
- c) Draw and explain the phasor diagram of a single phase transformer on No-load. 8
- Q6. a) Explain the various losses of a single phase transformer. 4
- b) Two wattmeters connected to measure power in a three phase circuit using the two wattmeter method indicate 1250 W and 250 W respectively. Find the total power supplied and the power factor of the circuit: when 8
- both the readings are positive,
 - when the latter reading is obtained by reversing the connections of the pressure coil.
- c) A $200/400 \text{ V}$, 50 Hz single phase transformer gave the following test results: 8
- OC test: 200 V 0.7 A 70 W (on lv side)
SC test: 15 V 10 A 85 W (on hv side)
Obtain the parameters and draw the equivalent circuit of the transformer as referred to the primary.
-

Note:

- i. Question No 01 is compulsory
 - ii. Attempt any 03 from remaining
 - iii. All questions carry equal marks
-

Q1. Attempt any Five

[15 Marks]

- a) Explain Food chain.
- b) Explain Environmental aspects of sustainable development.
- c) What is mean by E pollution?
- d) Differentiate between conventional and non conventional energy.
- e) Explain concept of carbon credit.
- f) explain Environmental Impact Assessment (EIA)
- g) Explain causes and effect of Ozone layer depletion.

Q2.

[15 Marks]

- a) Explain various modes needed for public awareness to protect earth from environmental degradation.
- b) Explain need and importance of Environmental studies.
- c) Explain the classification of ecosystem.

Q3.

[15 Marks]

- a) Explain principle, construction and working of venturi scrubber.
- b) What is men by water pollution? Explain sources and effects of water pollution.
- c) List the widely used methods for solid waste treatment. Explain any one in details.

P.T.O.

Q4

[15 Marks]

- a) Outline the important features of environmental clearance and authorization mechanism?
- b) What are important powers and functions of Central pollution control board?
- c) What do mean by Noise pollution? Explain sources and effects of Noise pollution.

Q5.

[15 Marks]

- a) How electricity is generated by using wind energy?
- b) State and explain principal, construction and working of flat plate collector used for solar energy.
- c) What are the limitations of conventional sources of energy?

Q6.

[15 Marks]

- a) Explain the case study of Kedarnath.
 - b) Explain the concept and objective of green building.
 - c) What are the various techniques of Disaster management.
-