

202
17/5/17

Max. Marks: 80

Time: 3 hrs.

N.B. : 1. Q1 is compulsory

2. Attempt any three questions from Q2 to Q6.

Q1. a) Show that $\int_0^{\infty} 3^{-4x^2} dx = \frac{\sqrt{\pi}}{4\sqrt{\log 3}}$ 3

b) Solve $(2y^2 - 4x + 5) dx = (y - 2y^2 - 4xy) dy$ 3

c) Solve the ODE $(D - 1)^2 (D^2 + 1)^2 y = 0$ 3

d) Evaluate $\int_0^1 \int_0^{x^2} e^x dy dx$ 3

e) Evaluate $\int_0^1 \frac{x^a - 1}{\log x} dx$ 4

f) Find the length of the cycloid from one cusp to the next, where

~~$x = a(1 - \cos \theta), y = a \sin \theta$~~

Q2. a) Solve $(D^2 - 3D + 2)y = 2e^x \sin\left(\frac{x}{2}\right)$ 6

b) Using DUIS prove that $\int_0^{\infty} e^{-\left(x^2 + \frac{a^2}{x^2}\right)} dx = \frac{\sqrt{\pi}}{2} e^{-2a}, a > 0$ 6

c) Change the order of integration and evaluate $\int_0^1 \int_x^{\sqrt{2-x^2}} \frac{x}{\sqrt{x^2 + y^2}} dx dy$ 8

Q3. a) Evaluate $\iiint_0^1 \frac{1}{(x+y+z)^3} dx dy dz$ 6

b) Find the mass of the lemniscate $r^2 = a^2 \cos 2\theta$ if the density at any point is proportional to the square of the distance from the pole. 6

c) Solve $x^2 \frac{d^3 y}{dx^3} + 3x \frac{d^2 y}{dx^2} + \frac{dy}{dx} + \frac{y}{x} = 4 \log x$ 8

Q4. a) Prove that for an astroid $x^{2/3} + y^{2/3} = a^{2/3}$, the line $\theta = \frac{\pi}{6}$ divide the arc 6

in the first quadrant in a ratio 1:3.

b) Solve $(D^2 - 7D - 6)y = (1 + x^2)e^{2x}$ 6

c) Apply Runge Kutta method of fourth order to find an approximate value of y when $x = 0.4$ given that $\frac{dy}{dx} = \frac{y-x}{y+x}$, $y = 1$ when $x = 0$ taking $h = 0.2$ 8

Q5. a) Use Taylor's series method to find a solution of $\frac{dy}{dx} = 1 + xy$, $y(0) = 0$ for $x = 0.2$ taking $h = 0.1$ correct to four decimal places. 6

b) Solve by the method of variation of parameters $\frac{d^2y}{dx^2} + y = \frac{1}{1 + \sin x}$ 6

c) Compute the value of $\int_{0.2}^{1.4} (\sin x - \ln x + e^x) dx$ using (i) Trapezoidal rule 8
(ii) Simpson's (1/3)rd rule (iii) Simpson's (3/8)th rule by dividing into six subintervals.

Q6. a) Using Beta function evaluate $\int_0^{\frac{\pi}{6}} \cos^6 3\theta \sin^2 6\theta d\theta$

b) Evaluate $\int_0^{\frac{\pi}{\sqrt{2}}} \int_y^{\sqrt{a^2-y^2}} \log(x^2 + y^2) dx dy$ by changing to polar coordinates 6

c) Evaluate $\iiint_V x^2 y z dx dy dz$ over the volume bounded by the planes 8

$x = 0, y = 0, z = 0$ and $\frac{x}{a} + \frac{y}{b} + \frac{z}{c} = 1$

295

FE - sem-II - CBCS

(Choice Based Grading System)

T0132 / T50011 APPLIED PHYSICS II.

23/5/17

Q.P. Code :09910

[Time: 2 Hours]

[Marks:60]

Please check whether you have got the right question paper.

- N.B:
1. Question no 1 is compulsory
 2. Attempt any three questions from Q.2 to Q.6.
 3. Use suitable data wherever required
 4. Figures to the right indicate full marks.

- Q.1 Attempt any five of the following 15
- A Why the Newton's rings are circular and fringes in wedge shaped film are straight?
 - B What is grating and grating element?
 - C The core diameter of multimode step index fibre is $50 \mu\text{m}$. The numerical aperture is 0.25. calculate the number of guided modes at an operating wavelength of $0.75 \mu\text{m}$. ?
 - D What is a population inversion state? Explain its significance in the operation of LASER.
 - E What is divergence of a vector field? Express it in Cartesian coordinate system.
 - F What do you mean by thin film? Comment on the colors in thin film in sun light
 - G An electron is accelerated through a potential difference of 18 kV in a color TV cathode ray tube. Calculate the kinetic energy and the speed of the electron.
- Q.2 A Derive the conditions for maxima and minima due to interference of light transmitted from thin film of uniform thickness. 08
- B Differentiate between step index and graded index fibre. 07
- An optical fibre has a numerical aperture of 0.20 and a refractive index of cladding is 1.59. Determine the core refractive index and the acceptance angle for the fibre in water which has a refractive index of 1.33.
- Q.3 A Explain the experimental method to determine the wavelength of spectral line using diffraction grating. 08
- What is the highest order spectrum which can be seen with monochromatic light of wavelength 6000 \AA by means of a diffraction grating with 5000 lines /cm?
- B Explain construction and working of He:Ne laser with neat label diagram. 07
- Q.4 A Explain Cylindrical co-ordinate system. State the transformation relation between Cartesian and Cylindrical co-ordinates. 05
- B Explain the concept of electrostatic focusing in electron optics. 05
- C Two optically plane glass strips of length 10cm are placed one over the other. A thin foil of thickness 0.01 mm is introduced between them at one end to form an air film. If the light used has wavelength 5900 \AA find the separation between consecutive bright fringes. 05
- Q.5 A With Newton's ring experiment explain how to determine the refractive index of liquid? 05
- B Using Spherical co-ordinate systems calculate the area of a disc of radius 2cm. 05
- C What are different techniques to synthesis nanomaterial? Explain one of them in detail. 05
- Q.6 A With neat diagram explain construction and working of Scanning electron microscope. 05
- B Explain the construction and reconstruction of hologram with neat diagram. 05
- C An electron is accelerated through a potential difference of 5 kV and enters a uniform magnetic field of 0.02 wb/m^2 acting normal to the direction of electron motion. Determine the radius of the path. 05

A4F3662AC57F7D38EAD99E5839F6D2D1

(REVISED COURSE) Q.P. Code : 1049

(2 Hours)

[Total Marks : 60

- N.B. : (1) Question No. 1 is Compulsory.
 (2) Attempt any three from remaining six questions
 (3) All questions carry equal marks.
 (4) Figures to the right indicate full marks.
 (5) Atomic weights : H=1, C=12, S=32, N=14, O=16, Cl=35.5, Ba=137.3, Na=23, Mg=24.

1. Answer any five from the following :- 15
- What are propellants ? State important characteristics of good propellant.
 - Compare Galvanizing and Tinning.
 - Give composition, properties and uses of Wood's Metal.
 - Write a note on 'Green Reagent'.
 - Define terms :-
 (i) Composite material (ii) Matrix phase (iii) Dispersed phase.
 - List three main constituents of Varnish & give functions of each.
 - A coal sample was subjected to ultimate analysis:
 1.6 gm of coal on combustion in a Bomb calorimeter gave 0.47 gm of BaSO₄
 Calculate % of sulphur in the coal sample.
2. (a) What is dry corrosion ? Explain with example how nature of oxidised product affect the rate of corrosion. 6
- (b) What is cracking ? Explain fixed bed catalytic cracking with diagram. 5
- (c) Calculate percentage atom economy for the following reaction w.r. to methyl iso-cyanate 4
- $$\text{CH}_3\text{NH}_2 + \text{COCl}_2 \rightarrow \text{CH}_3\text{-N=C=O} + 2\text{HCl}$$
- methyl iso cyanate.
3. (a) A gaseous fuel has the following composition by volume. 6
 CH₄ = 35% , C₂H₄ = 5% , CO = 15% , H₂ = 40% N₂ = 1 water vapour = 4%
 Calculate volume & weight of air required for complete combustion of 1m³ of fuel
 [mol.wt of air = 28.94]
- (b) Explain conventional & green synthesis of adipic acid. Mention the green chemistry principle involved. 5
- (c) How the rate of corrosion influenced by following factors. 4
 (i) PH of medium (ii) Over voltage.
4. (a) What is powder Metallurgy ? How are metal powders prepared using. 6
 (i) Atomization (ii) Chemical reduction
- (b) What is cathodic protection ? Explain Impressed current method of corrosion control. 5

TURN OVER

- (c) Write a note on 'Sandwich panel' type layered composites. 4
5. (a) What is Bio-diesel ? Explain the trans esterification method for its synthesis. 6
Mention advantages of biodiesel as fuel.
- (b) What are alloys ? Explain any four purposes of making alloys with suitable example 5
- (c) Discuss the physical factors influencing adhesive action. 4
6. (a) Write a note on differential aeration corrosion. 5
- (b) 2.5 gm of air dried coal sample was taken in a silica crucible , after heating it in an electric oven at 110°C for 1hr the residue was weighed 2.41 gm. The residue was heated in Silica crucible covered with vented lid at a temperature $925 \pm 25^{\circ}\text{C}$ for exactly 7 minutes. After cooling the weight of residue was found to contain 1.98 gm. The residue was then ignited to a constant weight of 0.246 gm. Report the results of above analysis. 5
- (c) Explain the effects of following elements on alloying :- 5
- (i) Nickel
 - (ii) Chromium
 - (iii) Cobalt
 - (iv) Molybdenum
 - (v) Carbon.

(3 HOURS)

Max Marks:60

- 1) Answer any **FOUR** questions.
- 2) Use **first** angle projection method **only**.
- 3) Assume any suitable dimension if required.

Q1 Figure given below shows two views of an object. Draw the following views to full scale:-

- i) Sectional Front view section P-P
- ii) Top View
- iii) Left hand Side view
- iv) Insert minimum 10 dimensions

05
04
04
02

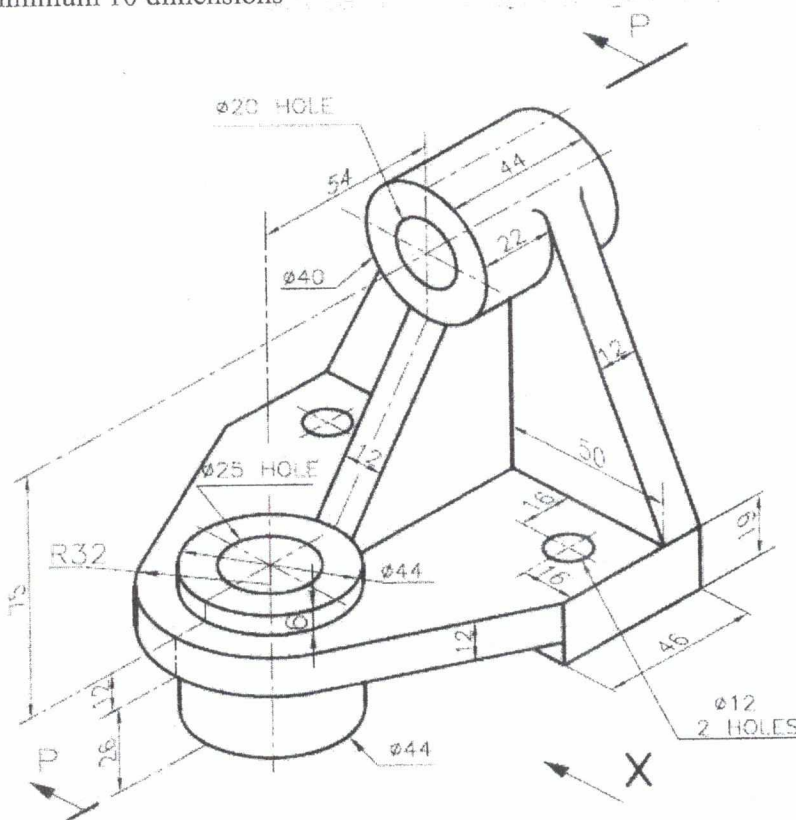

Q2 A tetrahedron of 70 mm sides has one of its edges in H.P. and inclined at 45° to the V.P. while a face containing that edge is vertical. Draw projections of the tetrahedron. 15

[TURN OVER

Q3 a) Draw the isometric view of the following using the natural scale

08

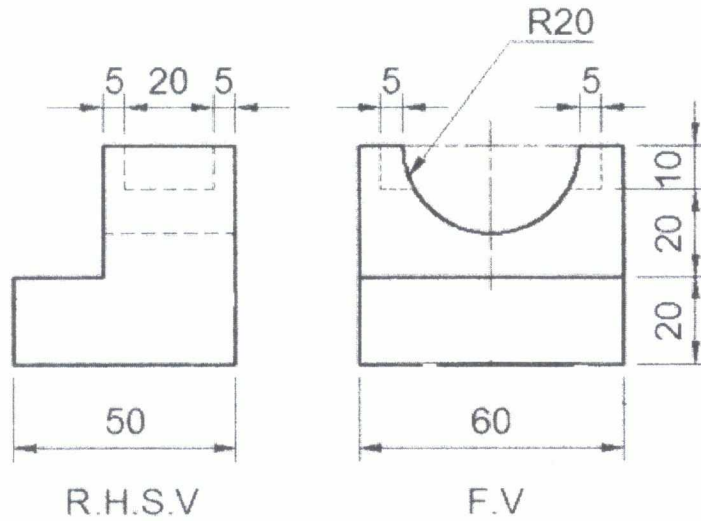

b) A triangular prism base 40 mm long and height of axis 65 mm has one of its base edges in H.P. and inclined at 40° to V.P. Draw projections when the axis is inclined at 45° to H.P. 07

Q4 a) Draw the isometric view of the following using the natural scale

07

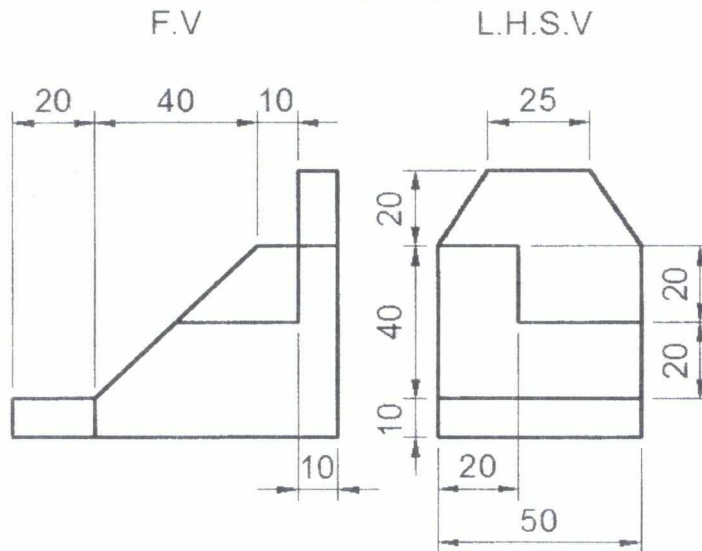

b) A line AB 70 mm long has its end A 10mm above H.P. and 20 mm in front of V.P. The line AB is inclined at 40° to H.P. and its front view is inclined at 65° to XY. Draw its projections and find inclination of AB with VP. 08

[TURN OVER

Q5 a) A pentagonal pyramid of 40 mm edge of base and 70 mm high stands vertically with its base on H.P. and an edge of base is perpendicular to V.P. A section plane perpendicular to H.P. and inclined at 30° to V.P. cuts the pyramid such that it passes through the pyramid at a shortest distance of 12 mm from the axis and in front of it. Draw sectional Front View, Top View showing the section and true shape of section. 08

b) A cone of 70 mm height of axis and base diameter 60 mm is resting on its base on H.P. It is cut by a section plane parallel to one of its end generators and 12 mm away from it. Draw development of lateral surface of truncated solid. 07

Q6 a) Figure given below shows two views of an object. Draw the following views to full scale.:-

- i) Front View from X 4
- ii) Top View 4
- iii) Insert minimum 6 dimensions 1

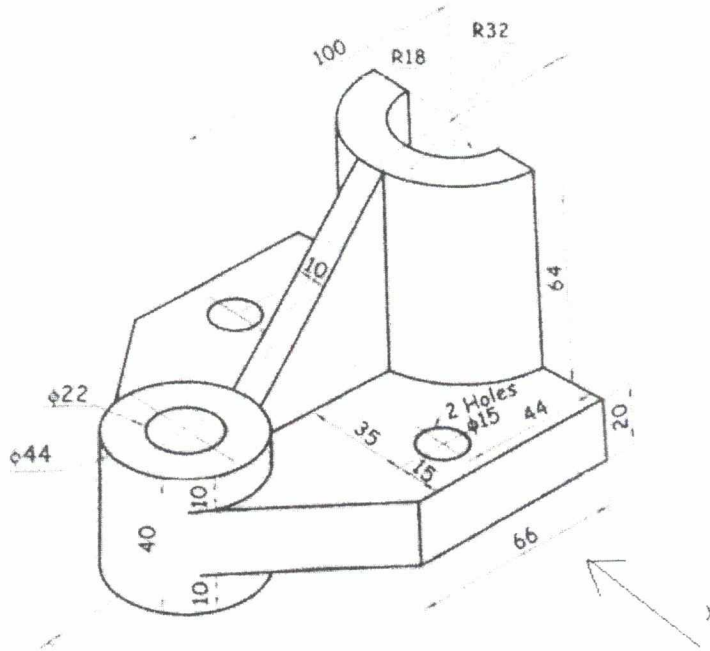

b) One end of an inelastic thread of 150 mm length is attached to one corner of a regular hexagonal disc having a side of 25 mm. Draw the curve traced out by the other end of the thread when it is completely wound along the periphery of the disc, keeping the thread always tight. 6

295

(3 Hours)

[Total Marks : 80]

N.B. :

1. Question Number 1 is compulsory.
2. Attempt any 3 questions from remaining 5 questions.
3. Figures to right indicate full marks.
4. Assume suitable data if necessary and state them clearly.

- Q 1.
- a. Convert 0010 0100 0010 1101 from base 2 to decimal. Convert 134 from base 10 to hexadecimal. Write steps of conversion. 4
 - b. Enlist all the data types in C language along with their memory requirements, format specifiers and range. 4
 - c. Draw flowchart for 'if else' and 'while' statements of C language. 4
 - d. What is use of storage classes? Explain extern storage classes with suitable example. 4
 - e. Differentiate between structure and union. 4
- Q 2.
- a. What is need of computer programming? What do you mean by structured programming? Develop an ALGORITHM and FLOWCHART to find reverse of a number. 10
 - b. Write a menu driven program to perform arithmetic operations on two integers. The menu should be repeated until the user selects 'STOP' option. Program should have independent user defined function for each case. 10
- Q 3.
- a. Write a program that creates two integer arrays of size 8 and 7. Initialize the arrays with random values. Sort the arrays in ascending order with the help of a user defined function namely 'sortArray'. Merge these arrays with the help of another user defined function named 'mergeArrays' which returns a new array. Program should display the arrays before and after sorting, also the merged array. 10
 - b. What are advantages and disadvantages of recursion? Comment on conditions to be considered while writing a recursive function. Write a program to print Fibonacci series up to N terms using a recursive function. 10

Turn Over

Q.P. Code :17098

[Time: Two Hours]

[Marks:40]

Please check whether you have got the right question paper.

- N.B:
1. Question.No.1 is compulsory.
 2. Attempt Any three out of five questions.

- Q.1 a) Write a short on objectives of communication. 03
- b) Read each sentence and fill the blank spaces choosing the correct word. 02
1. You will loose/lose your deposit if you cancel the order.
 2. He's a man who's/whose opinion I respect.
 3. He is one of the men who does/do the work.
 4. I would advise/advise extreme caution.
- c) Write short note on Complete block format with its diagrammatic representation. 03
- d) Construct the technical definition of the following. 02
- 1) Wall Clock
 - 2) Soldering
- Q.2 a) Explain non-verbal communication. 03
- b) List out principles of communication and explain two principles. 02
- c) As the Manager of Sangam Hotel, New Delhi, write a claim letter to the General Manager of Bharat Potteries, 05 Aligarh Road, Bhavanipur, telling him that most of the contents of the china ware which you had ordered from their firm have reached you in a damaged condition. Demand replacement or suitable compensation. Invent necessary details. (Use modified block form)
- Q.3 a) What is meant by external and internal communication? Explain internal communication. 03
- b) Match the following 02
- | A | B |
|-----------------|------------------------|
| 1) Date Line | a) Optional Part |
| 2) Subject Line | b) Reference Number |
| 3) RT/SYV | c) No Ordinals |
| 4) 12/VT/07 | d) identification Mark |
- c) As the sales Director of Fitness Plus Centre, Bangalore, draft a sales letter to Business Professions selling them 05 on your 3 wellness packages: (Use semi Block form)
1. The 3 day Fitness Weekend.
 2. The 7 day Total Fitness Programme
 3. The individualized corporate well Well-being Programme

Q.P. Code :17098

- Q.4 a) Write a short note on Email Etiquettes 03
- b) Classify the following instructions as Caution, Precaution, Warning, Note 02
1. Do not expose to the medicine to direct sunlight.
 2. Avoid smoking.
 3. Wear Hand gloves.
 4. Fill in the entries carefully
- c) Write short note on **any two**. 03
1. Silence
 2. Grapevine
 3. You Attitude
- d) Identify the barrier. 02
1. The Accounts officer, who always did his calculations manually, could not work on computing machine.
 2. A signboard read, "Fine for Parking
- Q.5 a) Explain in detail socio-psychological barriers. 03
- b) Provide one word substitute for the following sentence. 04
1. A contagious disease which spreads over a huge area.
 2. Borrows ideas and steal others words is called.
- c) Explain characteristics of good instructions. 03
- Q.6 a) Describe any ONE of the following objects giving definition, diagram, components and working of Smartphone or Water Purifier. 05
- b) Read the following passage carefully and answer the questions given below. 05
- The word euthanasia is of Greek origin and literally means "a good death." The American Heritage Dictionary defines it as "the act of killing a person painlessly for reasons of mercy," Such killing can be done through active means, such as administering a lethal injection, or by passive means, such as withholding medical care or food and water.
- In recent years in the United States, there have been numerous cases of active euthanasia in the news. They usually involve the deliberate killing of ill or incapacitated persons by relatives or friends who plead that they can no longer bear to see their loved ones suffer. Although such killings are a crime, the perpetrators are often dealt with leniently by our legal system, and the media usually portrays them as compassionate heroes who take personal risks to save another from unbearable suffering. The seeming acceptance of active forms of euthanasia is alarming, but we see a bigger, more insidious threat from passive forms of euthanasia, Every year, in hospitals and nursing homes around the country, there are growing numbers of documented deaths caused by caregivers withholding life sustaining care, including food and water, from vulnerable patients who cannot speak for themselves.

Q.P. Code :17098

While it is illegal to kill someone directly, for example with a gun or knife, in many cases the law has put its stamp of approval on causing death by omitting needed care. Further, many states have "living will" laws designed to protect those who withhold treatment, and there have been numerous court rulings which have approved of patients being denied care and even starved and dehydrated to death. Because such deaths occur quietly within the confines of hospitals and nursing homes, they can be kept hidden from the public. Most euthanasia victims are old or very ill, so their deaths might be attributed to a cause other than the denial of care that really killed them. Further, it is often relatives of the patient who request that care be withheld. In one court case, the court held that decisions to withhold life sustaining care may be made not only by close family members but also by a number of third parties, and that such decisions need not be reviewed by the judicial system if there is no disagreement between decision makers and medical staff. The court went so far as to rule that a nursing home may not refuse to participate in the fatal withdrawal of food and water from an incompetent patient!

"Extraordinary" or "heroic" treatment need not be used when the chance for recovery is poor and medical intervention would serve only to prolong the dying process. But to deny customary and reasonable care or to deliberately starve or dehydrate someone because he or she is very old or very ill should not be permitted. Most of the cases coming before the courts do not involve withholding heroic measures from imminently dying people, but rather they seek approval for denying basic care, such as administration of food and water, to people who are not elderly or terminally ill, but who are permanently incapacitated. These people could be expected to live indefinitely, though in an impaired state, if they were given food and water and minimal treatment. No one has the right to judge that another's life is not worth living. The basic right to life should not be abridged because someone decides that someone else's quality of life is too low. If we base the right to life on quality of life standards, there is no logical place to draw the line. To protect vulnerable patients, we must foster more positive attitudes towards people with serious and incapacitating illnesses and conditions. Despite the ravages of their diseases, they are still our fellow human beings and deserve our care and respect. We must also enact positive legislation that will protect vulnerable people from those who consider their lives meaningless or too costly to maintain and who would cause their deaths by withholding life-sustaining care such as food and water.

1. Why author finds starvation and dehydration induced euthanasia is to be "more insidious"?
2. What is mean by word "euthanasia"?
3. When need not be to used "Extraordinary" or "heroic" treatment.
4. What is the best synonym for insidious?
 - A. mischievous B. Treacherous C. Seductive D. Apparent E. cumulative
5. Give suitable title for above passage