

41

(3 Hours)

Total Marks :80

N.B. (1) Question No. 1 is compulsory

(2) Solve any Three from the remaining.

(3) Figure in right indicates full marks.

Q.1)(a) Prove that $\frac{1}{1 - \frac{1}{(1 - \sec^2 x)}} = -\sinh^2 x$ 3

(b) If $z(x+y) = (x^2 + y^2)$ Prove that $\left(\frac{\partial z}{\partial x} - \frac{\partial z}{\partial y}\right)^2 = 4\left(1 - \frac{\partial z}{\partial x} - \frac{\partial z}{\partial y}\right)$ 3

(c) If $u = e^x \cos y, v = e^x \sin y$ find $\frac{\partial(u,v)}{\partial(x,y)}$ 3

(d) Using Maclaurin's series prove that $e^x \log(1+x) = x + \frac{x^2}{2!} + \frac{2x^3}{3!} + \dots$ 3

(e) Prove that the matrix $\frac{1}{\sqrt{3}} \begin{bmatrix} 1 & 1+i \\ 1-i & -1 \end{bmatrix}$ is Unitary. 4

(f) Find the nth Derivative of $y = \cos x \cos 2x \cos 3x$ 4

Q.2) (a) Find the roots common to $x^4 + 1 = 0$ and $x^6 - i = 0$ 6

(b) Find the nonsingular matrices P and Q such that PAQ is in Normal Form . Also find rank of A 6

Where $A = \begin{bmatrix} 1 & 2 & 3 & 4 \\ 2 & 1 & 4 & 3 \\ 3 & 0 & 5 & -10 \end{bmatrix}$

(c) State and Prove Eulers theorem for Homogeneous functions on two variables and hence 8

find the value of $x \frac{\partial u}{\partial x} + y \frac{\partial u}{\partial y}$ if $u = \frac{1}{x^2} + \frac{1}{xy} + \frac{\log x - \log y}{x^2 + y^2}$

Q.3(a) Determine the values of K for which the following equations are consistent. Also solve 6

the system for these values of k $x + 2y + z = 3, x + y + z = k, 3x + y + 3z = k^2$

(b) Find the stationary values of $f(x,y) = y^2 + 4xy + 3x^2 + x^3$ 6

(c) If $\tan(\alpha + i\beta) = \cos \theta + i \sin \theta$ Prove that $\alpha = \frac{n\pi}{2} + \frac{\pi}{4}$ and $\beta = \frac{1}{2} \log \tan\left(\frac{\pi}{4} + \frac{\theta}{2}\right)$ 8

Turn Over

Q.4(a) If $u = \log(x^3 + y^3 + z^3 - 3xyz)$ Prove that $\left(\frac{\partial}{\partial x} + \frac{\partial}{\partial y} + \frac{\partial}{\partial z}\right)^2 u = -\frac{9}{(x+y+z)^2}$ 6

(b) Prove that principal value of $(1 + \tan \alpha)^{-i}$ is $e^\alpha [\cos(\log \cos \alpha) + i \sin(\log \cos \alpha)]$ 6

(C) Apply Crouts method to solve system of linear Equations $x + y + z = 3,$
 $x + 2y + 3z = 4$ 8
 $x + 4y + 9z = 6$

Q.5(a) Find the constants a,b,c so that $\lim_{x \rightarrow 0} \frac{x(a + b \cos x) - c \sin x}{x^5} = 1$ by L'Hospitals rule 6

(b) Prove That $e^{e^x} = e \left[1 + x + x^2 + \frac{5}{6}x^3 + \frac{5}{8}x^4 + \dots \right]$ 6

(c) If $x = \tan(\log y)$ prove that $(1 + x^2)y_{n+1} + (2nx - 1)y_n + n(n-1)y_{n-1} = 0$ 8

Q.6(a) If $A = \begin{bmatrix} 1/3 & 2/3 & a \\ 2/3 & 1/3 & b \\ 2/3 & -2/3 & c \end{bmatrix}$ is orthogonal find a,b,c. 6

(b) Fit a straight line $y = a + bx$ to the following data 6

x	1	2	3	4	5	6
y	49	54	60	73	80	86

(C) If $\frac{x^2}{a^2 + u} + \frac{y^2}{b^2 + u} + \frac{z^2}{c^2 + u} = 1$, prove that $\left(\frac{\partial u}{\partial x}\right)^2 + \left(\frac{\partial u}{\partial y}\right)^2 + \left(\frac{\partial u}{\partial z}\right)^2 = 2 \left(x \frac{\partial u}{\partial x} + y \frac{\partial u}{\partial y} + z \frac{\partial u}{\partial z} \right)$

Given that u is an implicit function of x,y,z. 8

68

FE-Sem-I - CBSGS - (R-2012)

8/6/17

T0121 / T1865 APPLIED PHYSICS I.

Q.P. Code:17199

Time : 2 Hours

Marks : 60

1. Question number 1 is compulsory
2. Attempt any three from question number 2 to 6
3. Assume suitable data with justification
4. Figures to the right indicate maximum marks.

Q.1. Solve any five from the following [15]

- (a) Justify use of X- rays in the study of crystals.
- (b) Draw the following [231], (213), (102)
- (c) Derive APF for FCC
- (d) Describe Magnetostriction effect.
- (e) The resistivity of Cu is 1.72×10^{-8} Ohm- m. Calculate the mobility of electrons in Cu. Given that number of electrons per unit volume is $10.41 \times 10^{28} \text{ m}^{-3}$.
- (f) What is cavitation?

Q.2 (a) What is Fermi level? Show that it is located at the centre of forbidden energy gap. Find the resistivity of Cu assuming that each atom contributes one free electron .Consider density = 8.96 gm/ cubic cm, Atomic weight =63.5, mobility of electron = $43.3 \text{ cm}^2/\text{V-sec}$ [8]

(b) Calculate APF for HCP structure [7]

Q.3 (a) Derive Bragg's law and using it calculate the smallest glancing angle at which X-rays of 1.549 Angstrom will be reflected from a crystal having spacing of 4.255 Angstrom. [8]

(b) A metal ring having cross section 5 cm^2 and diameter of 20 cm has a coil of 200 turns wound over it. Determine the current required to produce flux of 4 milli weber. Consider the metal with relative permeability as 380. [7]

Q.4 (a) Explain with neat diagram different phases of liquid crystal. State any two applications of liquid crystals. [5]

(b) Explain in detail "electronic polarization" [5]

(c) Define the term "mobility" Write any formula to obtain it. Write its unit. [5]

Q.5 (a) Explain the principle of solar cell. What are main features of its construction? [5]

(b) What are the conditions of good acoustics? Give some methods to design a hall with good acoustics. [5]

- (c) Derive critical radius ratio for ligancy 6. [5]
- Q.6 (a) Explain how to produce ultrasonic waves with the help of piezo electric effect. [5]
- (b) What is Hall effect? How to find carrier concentration using it in semiconductors? [5]
- (c) Calculate reverberation time for an empty hall of size $21 \times 16 \times 10 \text{ m}^3$ with absorption coefficient 0.106 [5]

+++++

Please check whether you have got the right question paper.

- N.B: 1. Question.No.1 is compulsory.
 2. Answer any three questions from the remaining five.
 3. All questions carry equal marks
 4. Atomic Weights: Ca=40, Mg=24, H=1, C=12, O=16, Cl=35.5, Na=23, S=32.

- Q. 1 **Answer any five of following :** 15
- Which buffer solution is added during determination of hardness of water by EDTA titration and why?
 - Give the preparation, properties and uses of Kevlar.
 - Why does graphite act as a good lubricant on the surface of the moon?
 - Define component with example.
 - What is concrete? What are its uses?
 - Explain role of plasticizer in compounding of plastic.
 - Calculate temporary and total hardness of a sample of water containing following impurities; $\text{Ca}(\text{HCO}_3)_2=162 \text{ mg/L}$, $\text{MgCl}_2=95 \text{ mg/L}$, $\text{NaCl}=58.5 \text{ mg/L}$, $\text{Mg}(\text{HCO}_3)_2=73 \text{ mg/L}$, $\text{CaSO}_4=136 \text{ mg/L}$.
- Q. 2 a) The analysis of water is as follows: 6
 $\text{CaCl}_2 = 30 \text{ ppm}$, $\text{MgSO}_4 = 15 \text{ ppm}$, $\text{NaHCO}_3 = 24.4 \text{ ppm}$, $\text{CO}_2 = 60 \text{ ppm}$, $\text{H}_2\text{SO}_4 = 65 \text{ ppm}$. Calculate the amount of lime (80% pure) and soda (90% pure) required to soften one million liters of water.
- Explain behavior of water with respect to temperature and pressure as one component system with phase diagram. 5
 - Discuss chemical vapour deposition method for CNT synthesis. 4
- Q. 3 a) Explain following properties of lubricant with their significance 6
- Emulsification
 - Flash point and Fire point
 - Saponification Value
- b) Give reason: 5
- PVC is soft whereas Bakelite is hard
 - Natural rubber need vulcanization
- c) Calculate number of phases present in the following systems: 4
- $\text{MgCO}_3(\text{s}) \rightleftharpoons \text{MgO}(\text{s}) + \text{CO}_2(\text{g})$
 - $\text{NH}_4\text{Cl}(\text{s}) \rightleftharpoons \text{NH}_3(\text{g}) + \text{HCl}(\text{g})$
 - Rhombic Sulphur (s) \rightleftharpoons Monoclinic Sulphur (s)
 - $\text{Ice}(\text{s}) \rightleftharpoons \text{Water}(\text{l}) \rightleftharpoons \text{Vapour}(\text{g})$
- Q.4 a) What is fabrication of plastic? Explain the injection moulding process with a neat diagram. 6
- b) Explain following 5
- Explain role of bleaching powder in disinfection of water
 - Define BOD and give its significance

Q.P. Code :17155

- c) Find the Acid value of given oil whose 20ml required 2.8 ml of N/10 KOH during titration (Density of oil=0.86gm/ml). From acid value state whether the oil is useful for lubrication or not. 4
- Q.5 a) Write a note on (any two) 6
- i. RCC
 - ii. Silica bricks
 - iii. Setting and hardening of cement
- b) Write a note on conducting polymer. 5
- c) The hardness of 100,000 liters of a sample of water was completely removed by passing it through a zeolite softener. The softener then required 400 liters of sodium chloride solution containing 100 gm/liter of NaCl for regeneration. Calculate the hardness of the water sample. 4
- Q.6 a) Explain following 6
- i. Explain principle involved in Ion exchange process
 - ii. Electrodialysis
- b) Give preparation and uses of 5
- i. Perlon U (or Isocyanate Rubber)
 - ii. Polymethyl methacrylate (PMMA)
- c) Define lubrication. Explain Boundary film lubrication 4

98

(3Hrs.)

Total Marks: 80

- N.B.
- 1 Question number 1 is compulsory
 - 2 Attempt any 3 questions from remaining questions
 - 3 Figure to right of the question indicates full marks
 - 4 Assume suitable data wherever necessary.
 - 5 Assume Acceleration due to gravity value $g = 9.81 \text{ m/s}^2$

- Q1 a) Determine the resultant of the following parallel forces and locate the position of resultant w.r.t. point O. Take radius $r = 50 \text{ cm}$ [4]

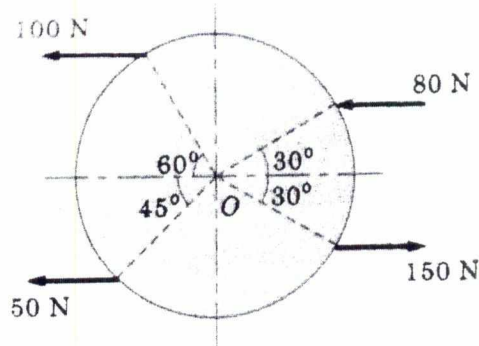

- b) Two 6° wedges are used to push a block horizontally as shown. Calculate the minimum force required to push the block of weight 500 N . Take $\mu = 0.2$ for all contact surfaces. [4]

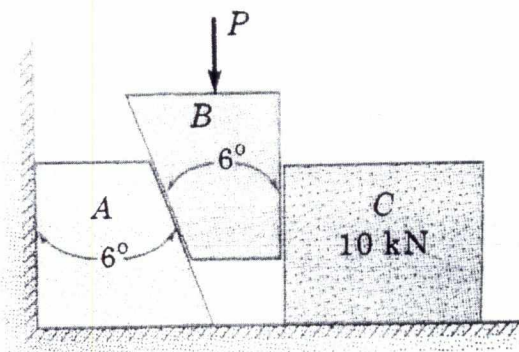

- c) of weight 8 kN moving from rest with constant acceleration acquires an upward velocity of 4 m/s over a distance of 5 m . Determine the tension in the cables supporting the lift. [4]
- d) Find the value of 'P' which will disturb the equilibrium of the system $\mu = 0.35$ [4]

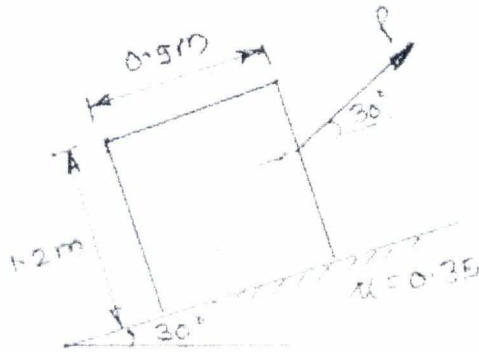

e) The position of a particle which moves along a straight line is given by [4]
 $x = t^3 - 6t^2 - 15t + 40$ where x is in meters and t is in seconds. Find the time at which velocity will be zero. Also find the position of the particle in that time

Q2 a) Two smooth spheres 1 and 2 having a mass of 2 Kg and 4 Kg respectively [8]
 collide with initial velocities as shown in fig. if the co-efficient of restitution for the spheres is $e=0.8$, determine the velocities of each sphere after collision. Angles made by velocities U_1 and U_2 with line of impact are 30° and 60° respectively.

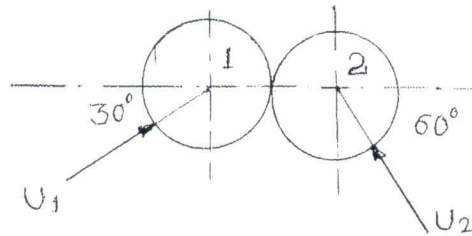

b) Find the resultant force and its direction? [4]

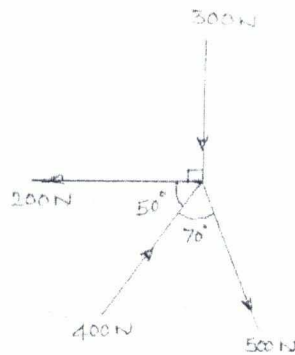

- c) The a-t diagram for the linear motion is shown in Fig. Construct velocity time [8]
and displacement time diagrams for the motion assuming that the motion starts
with initial velocity of 5 m/s from the starting point.

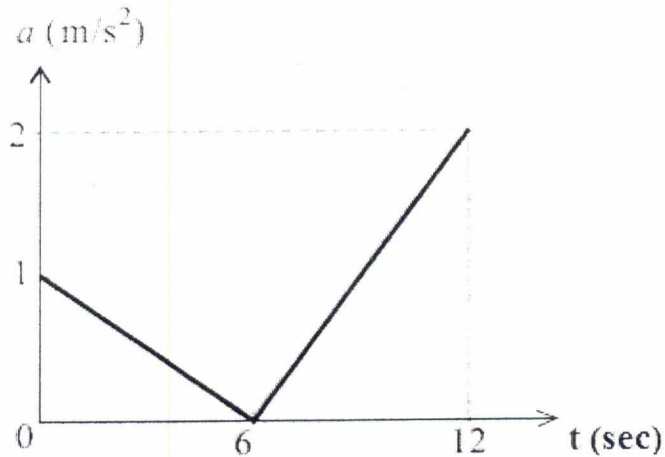

- Q3 a) Find centroid of the given shaded area with reference to O. [8]

[08]

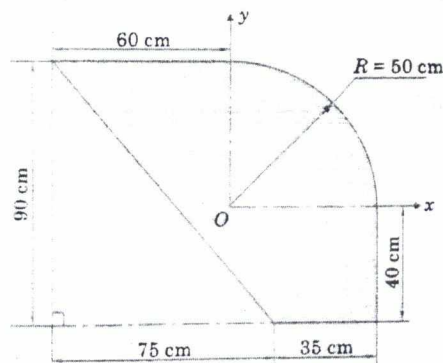

- b) A ball is thrown in the air with velocity of 4 m/sec. at an angle of 30° with the [6]
horizontal. Determine maximum height reached and range. State condition for
maximum range and find maximum range.
- c) Determine the force F in the cable shown in figure so that the resultant of three [6]
coplanar concurrent forces acting at point A is vertical. Also find the resultant

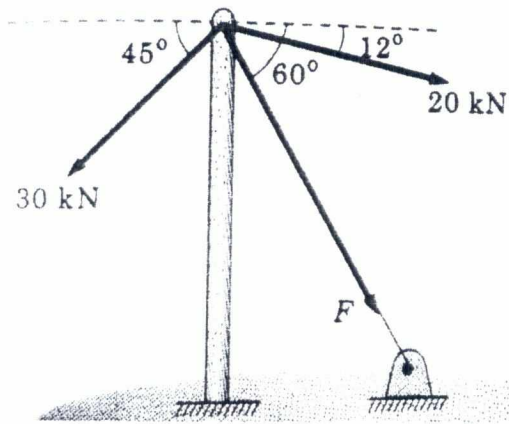

Q4 a) Find analytically the support reaction at B and the load P, for the beam to be in equilibrium as shown in the figure [8]

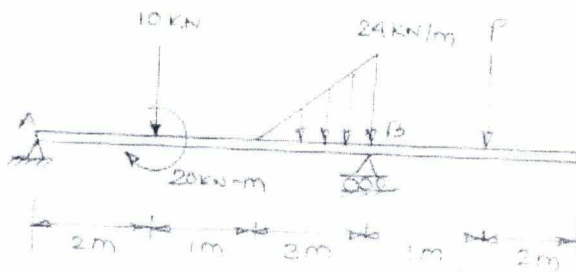

- b) A 50 kg block kept on the top of a 15° sloping surface is pushed down the plane with an initial velocity of 20 m/s. If $\mu_k = 0.4$, determine the distance traveled by the block and the time it will take as it comes to rest. [6]
- c) At the position shown in Fig. the crank AB has angular velocity of 3 rad/sec clockwise. Find the velocity of slider C and the point D at the instant shown. [6]

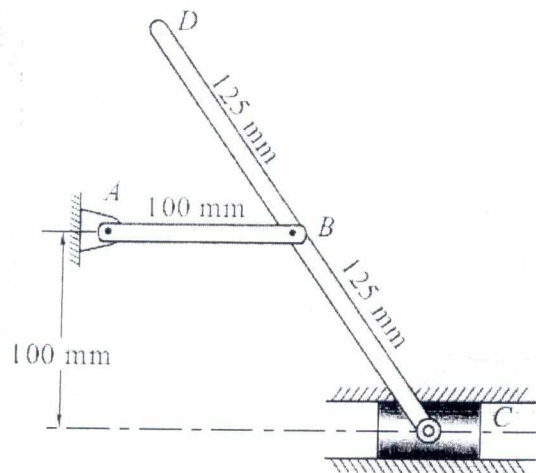

- Q5 a) For the truss shown in figure. Calculate forces in members BC, CD, DE, and EF by method of section. [8]

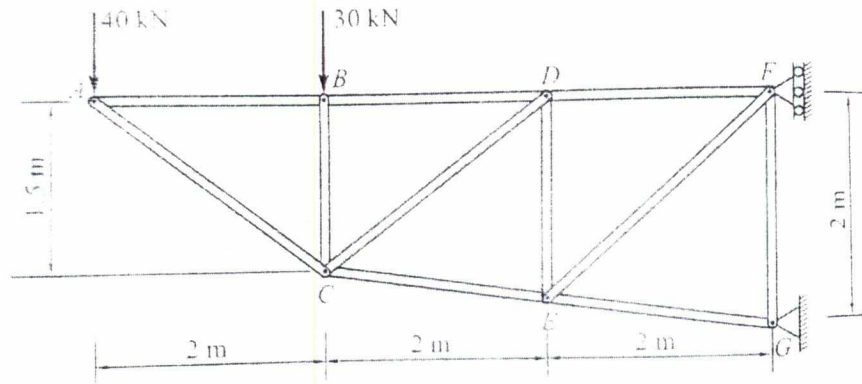

- b) A stone is dropped into a well and sound of splash is heard after 5 seconds. [6]
Find the depth of the well up to the water level assuming the velocity of sound to be 340m/s.
- c) The batsman hits a ball of 150 grams coming to him straight with a speed of 72kmph at an angle of 45° with horizontal and velocity of hit is 216 kmph. Find the average force exerted by the bat on the ball if the impact lasts for 0.02 sec. [6]
- Q6 a) The acceleration of an oscillating particle is defined by the relation $a = -kx$. [4]
Determine (i) the value of k such that $v = 15$ m/sec when $x = 0$ and $v = 0$ when $x = 3$ m and (ii) the speed of the particle when $x = 2$ m.

- b) Roller of mass 3 kg is supported by string as shown in figure , find the tension [4]
in the string and reaction at point B if the system is in equilibrium, given AC
= 120 mm

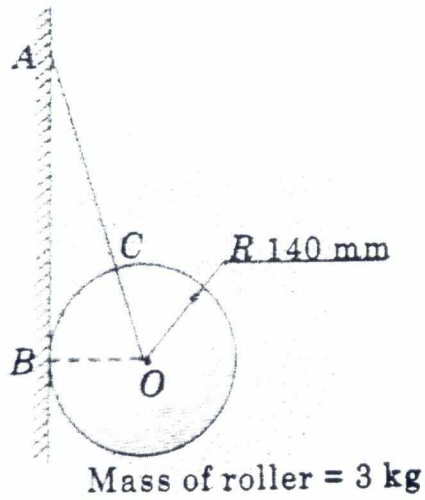

- c) 20 N block A and 30 N block B are supported by an inclined plane which is [4]
held in position as shown in fig. Knowing that the coefficient of friction is
0.15, between the two blocks and zero between block B and incline, determine
the value of θ for which motion is impending.

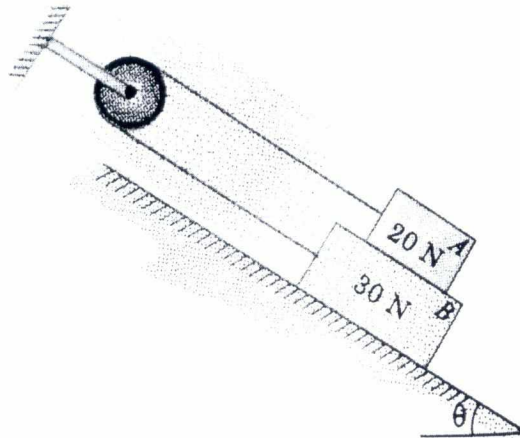

- d) Figure shows a collar of mass 20 kg which is supported on the smooth rod. [8]
 The attached springs are undeformed when $d = 0.5$ m. Determine the speed of the collar after the applied force of 100 N causes it to displace so that $d = 0.3$ m. The collar is at rest when $d = 0.5$ m. Use work energy principle.

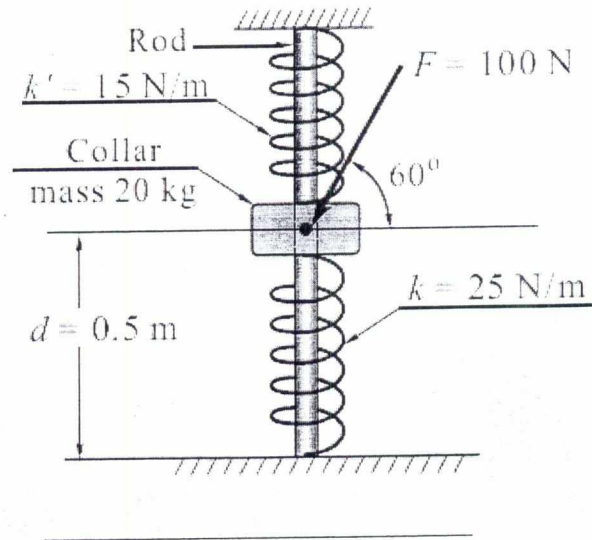

Correction

University of Mumbai <support@muapps.in>

To: controllerktr@yashod.com



University of Mumbai

Correction in QP code-18134

Q 1 b:- For the block of weight 500 N and corrected value is 10KN

University of Mumbai

<https://muapps.in>

support@muapps.in

022-26534263 / 022-26534266

You have received this email because you are registered with us.

To unsubscribe: please reply to this mail with subject "Unsubscribe"

University of Mumbai <support@muapps.in>

To: controllerkto@yahoo.com



University of Mumbai

Correction in QP code 18134 Question 1 C
Please read question as A lift of weight 8 KN

University of Mumbai

<https://muapps.in>

support@muapps.in

022-26534263 / 022-26534266

You have received this email because you are registered with us.

To unsubscribe, please reply to this mail with subject "Unsubscribe"

TOTAL MARKS: 80

TIME: 3hrs

NB

- 1) Question No. 1 is compulsory.
- 2) Answer any three questions out of remaining five questions.
- 3) Assumption made should be clearly stated.
- 4) Answer to questions should be grouped together and written together.

- Q1 a. Find current through $2\ \Omega$ resistor using star delta transformation 3

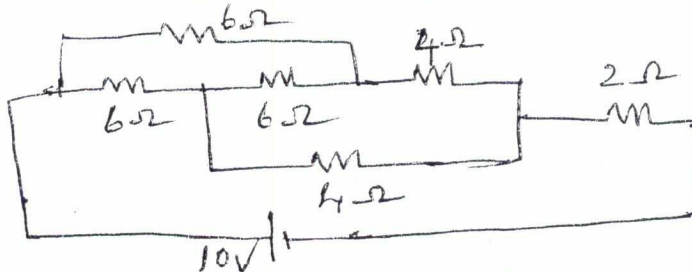

- b. Find Thevenin's equivalent circuit across AB 3

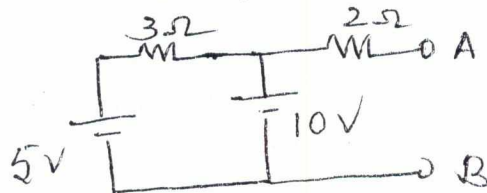

- c. An alternating voltage is represented by $v = 141.4 \sin 377t$, find frequency, time period and time at which voltage is 100 V for the first time 3
 - d. Prove that for a pure capacitor average power drawn over one complete cycle is zero 3
 - e. Draw a three phase delta connected load connected across a three phase supply, mark phase voltage, phase current, line voltage and line current 2
 - f. Derive the induced emf equation of a single phase transformer. 4
 - g. Draw the input and output voltage waveform of a half wave rectifier. 2
- Q2 a. Using Mesh analysis find current through $2\ \Omega$ resistor. 6

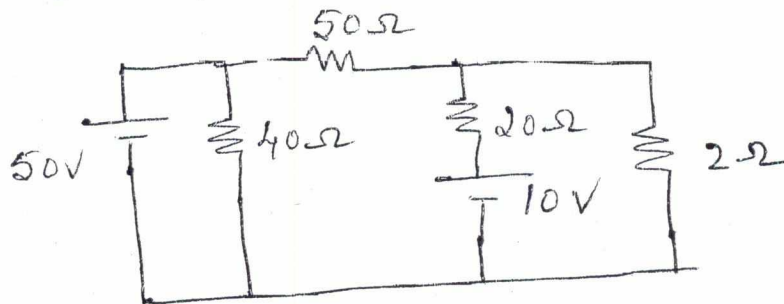

[TURN OVER

- b. A choke coil of $10\ \Omega$ resistance and $0.1\ \text{H}$ inductance is connected in series with a capacitor of $200\ \mu\text{F}$ across $230\ \text{V}$, $50\ \text{Hz}$ supply. Calculate circuit impedance, current, power factor, power dissipated in the coil and voltage across coil. 8
- c. Draw phasor diagram of a single phase transformer connected to a resistive load. 6
- Q3 a. Three identical impedance are connected in star to a three phase supply of $400\ \text{V}$. The line current is $30\ \text{A}$ and the total power taken from the supply is $14\ \text{kW}$. Calculate resistance and reactance value of each impedance. 8
- b. Open circuit and short circuit test on a $5\ \text{kVA}$, $200/400\ \text{V}$, $50\ \text{Hz}$ single phase transformer gave the following test results.
Open circuit test(L.V side): $200\ \text{V}$, $1\ \text{A}$, $100\ \text{W}$
Short circuit test(with primary short circuited): $15\ \text{V}$, $10\ \text{A}$, $85\ \text{W}$
Find the equivalent circuit parameters and draw it referred to primary side. 6
- c. Illustrate with the output characteristics, the active region, saturation region and cut off region of a CE transistor configuration. 4
- d. Compare the performance of capacitor filter with inductor filter 2
- Q4 a. Find current through $2\ \Omega$ using source transformation. 7

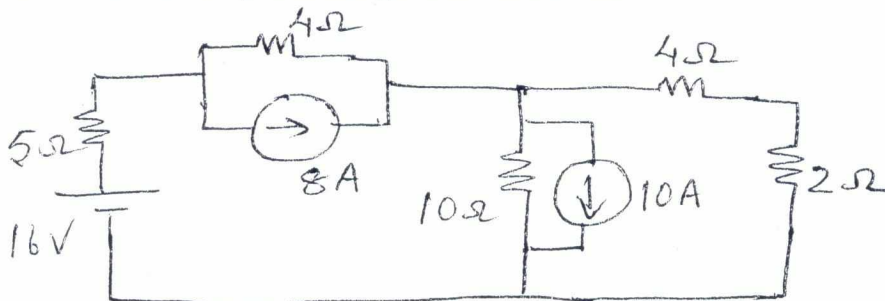

- b. Two wattmeter are connected to measure power in a three phase circuit. The reading of one wattmeter is $7\ \text{kW}$ when the load power factor is unity. If the power factor of the load is changed to 0.707 lagging without changing the total input power, calculate the reading of two wattmeters 4
- c. Find the expression for the sum of three voltages in instantaneous form where 5
- $$V_1 = 6 \sin(\omega t + 35^\circ)$$
- $$V_2 = 5 \sin(\omega t - 150^\circ)$$
- $$V_3 = 6 \cos(\omega t + 40^\circ)$$
- d. With neat circuit diagram explain the working of a full wave bridge rectifier. Draw output voltage and current waveform 4

[TURN OVER

- Q5 a. Find the value of R_L for which maximum power get dissipated and also calculate the maximum power 8

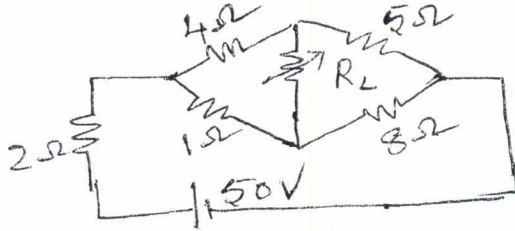

- b. Find currents through each branch 4

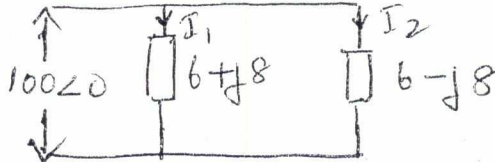

- c. Develop complete equivalent circuit of a single phase transformer 8

- Q6 a. Find current through 15 Ω resistor using superposition theorem. 7

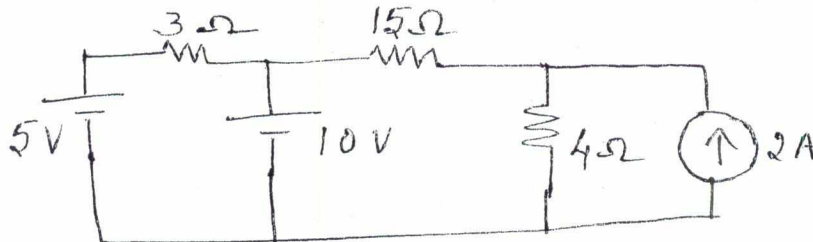

- b. An R-L-C series circuit with a resistance of 10 Ω, inductance of 0.2 H and a capacitance of 40 μF is supplied with a 100 V supply at variable frequency. Find the following with respect to series resonance circuit. 7
1. The frequency at which resonance takes place
 2. Current at resonance
 3. Power and power factor
 4. Q-factor
- c. Derive power and power factor in a balanced three phase star connected circuit under two watt meters measurement in terms of wattmeter reading. Draw relevant connections and phasor diagram. 6

[Time: 2 Hours]

[Marks:60]

Please check whether you have got the right question paper.

- N.B:
1. Question.No.1 is compulsory.
 2. Attempt any three questions from Q.2 to Q.6
 3. Draw neat labelled diagrams where necessary.
 4. Figures to the right indicate full marks.

- Q.1** Attempt **any five** from the following :- [15]
- a) What are the global problems pertaining to sanitation?
 - b) When environmental consent is required to be taken? Why?
 - c) What are the causes of ozone layer depletion? What adverse effects are produced by it?
 - d) Why our development should be 'Sustainable'?
 - e) Why in recent times attention is focused on renewable sources of energy?
 - f) What are the causes of 'Acid - rain'? What are its effects?
 - g) How technology can be used to better our environment?
- Q.2**
- a) How developing appropriate technology can lead us to sustainable development? [05]
 - b) Explain how industrial waste water treatment is carried out? [05]
 - c) Draw a neat diagram and explain the process that generates electricity from geothermal energy? [05]
- Q.3**
- a) Explain briefly how solid waste is managed by land filling. [05]
 - b) Write important Powers and Functions of State Pollution Control Board (SPCB). [05]
 - c) Explain various objectives of 'Green Building'. [05]
- Q.4**
- a) What causes depletion of natural soil resources? What are its effects? [05]
 - b) Write important features of 'Environmental Protection Act'. [05]
 - c) Explain hydropower generation with the help of suitable diagram. [05]
- Q.5**
- a) 'Resource Utilization as per Carrying Capacity', is an important measure for sustainable development- Explain. [05]
 - b) Draw a neat diagram of venturi scrubber and explain its working. [05]
 - c) Draw a neat diagram of flat plate collector and explain how is it useful in trapping the solar energy? [05]
- Q.6**
- a) What are the reasons for depletion of natural water resources? What is its impact? [05]
 - b) Write sources of E - pollution? What adverse effects are caused by it? [05]
 - c) How the techniques of disaster management are useful in the event of Tsunami? [05]
