

(00)

Q. P. Code: 16067

Duration – 3 Hours

Total Marks: 80

(1) N.B.:- Question no 1 is compulsory.

(2) Attempt any THREE questions out of remaining FIVE questions.

1) a) Solve $(1+e^{x/y})dx + e^{x/y}\left(1-\frac{x}{y}\right)dy = 0$ (4)

b) Solve $\frac{d^4y}{dx^4} + 5\frac{d^2y}{dx^2} - 36y = 0$ (3)

c) Evaluate $\int_0^{\infty} e^{-x^4} dx$ (3)

d) Express the following integral in polar co-ordinates (4)

$$I = \int_0^a \int_{\sqrt{ax-x^2}}^{\sqrt{a^2-x^2}} f(x,y) dx dy$$

e) Prove that $\left(\frac{E^4-1}{\Delta}\right) y_0 = y_0 + y_1 + y_2 + y_3$. (3)

f) Evaluate $I = \int_0^{\pi/2} \int_{\pi/2}^{\pi} \cos(x+y) dx dy$ (3)

2 a) Solve $\frac{dy}{dx} - \frac{\tan y}{1+x} = (1+x)e^x \sin y$. (6)

b) Change the order of integration and evaluate $I = \int_0^1 \int_{4y}^4 e^{x^2} dx dy$ (6)

c) Evaluate $\int_0^{\pi} \frac{dx}{a+b \cos x}$ $a > 0, |b| < a$ and hence deduce that (8)

$$\int_0^{\pi} \frac{dx}{(a+b \cos x)^2} = \frac{\pi a}{(a^2 - b^2)^{3/2}} \quad \text{and} \quad \int_0^{\pi} \frac{\cos x dx}{(a+b \cos x)^2} = \frac{-\pi a}{(a^2 - b^2)^{3/2}}$$

3 a) Evaluate $I = \int_0^{\log 2} \int_0^x \int_0^{x+y} e^{x+y+z} dx dy dz$ (6)

b) The density at any point of a cardioide $r = a(1 + \cos \theta)$ varies as the square of its distance from its axis of symmetry. Find its mass. (6)

c) Solve $(5+2x)^2 \frac{d^2y}{dx^2} - 6(5+2x) \frac{dy}{dx} + 8y = 6x$ (8)

- 4 a) Show that the length of the arc of the curve $y = \log\left(\frac{e^x - 1}{e^x + 1}\right)$ from $x=1$ to $x=2$ is $\log\left(e + \frac{1}{e}\right)$ (6)
- b) Solve $(D^3 - 2D^2 + D)y = x^2 + x$ (6)
- c) Use Runge-Kutta method of fourth order to compute $y(0.1)$ & $y(0.2)$, given $y' = xy + y^2, y(0) = 1$ (8)
- 5 a) Use method of variation of parameters to solve $\frac{d^2y}{dx^2} + y = \frac{1}{1 + \sin x}$ (6)
- b) Using Taylor's series method, find $y(1.1)$ correct to four decimal places, given $y' = xy^{1/3}$ and $y(1) = 1$. (6)
- c) Find the value of the integral $\int_0^1 \frac{x^2}{1+x^3} dx$ by taking $h = 0.2$, using (8)
 (i) Trapezoidal Rule (ii) Simpson's 1/3 Rule.
 Compare the errors with the exact value of the integral
- 6 a) The equation of an L-R circuit is given by $L \frac{di}{dt} + Ri = 10 \sin t$, if $i = 0$ at $t = 0$, express i as a function of t . (6)
- b) Evaluate $\iiint (x^2y^2 + y^2z^2 + z^2x^2) dx dy dz$ over the volume of the sphere $x^2 + y^2 + z^2 = a^2$ (6)
- c) Find the volume cut off from the paraboloid $x^2 + \frac{1}{4}y^2 + z = 1$ by the plane $z = 0$. (8)

Time: 2 Hours

Marks: 60

- N.B.**
- 1) Question No.1 is compulsory.
 - 2) Attempt any three questions from Q. No. 2 to 6.
 - 3) Figures to the right indicate full marks.

Q.1 Attempt any FIVE.

15

- a) Why does an excessively thin film appear to be perfectly dark when illuminated?
- b) A grating has 620 rulings /mm & is 5.05 mm wide. What is the smallest wavelength interval that can be resolved in the third order at $\lambda = 481 \text{ nm}$?
- c) Why would you recommend use of optical fibre in communication system?
- d) An electron is bound in a one dimensional potential well of width 2 \AA but of infinite height. Find its energy values in the ground state and first excited state?
- e) Explain the measurement of frequency of AC signal using Cathode Ray Oscilloscope?
- f) Distinguish between spontaneous emission & stimulated emission?
- g) Define superconductivity, critical temperature & critical magnetic field.

Q.2 a) How is Newton's ring experiment used to determine wavelength of a monochromatic source of light? In Newton's rings experiment the diameter of n^{th} & $(n+8)^{\text{th}}$ bright rings are 4.2 mm & 7 mm respectively. Radius of curvature of the lower surface of lens is 2m. Determine the wavelength of light? 8

b) An optical fibre has core diameter of $6 \mu\text{m}$ and its core refractive index 1.45. The critical angle is 87° . Calculate i) refractive index of cladding ii) acceptance angle iii) the number of modes propagating through fibre when wavelength of light is $1 \mu\text{m}$. 7

Q.3 a) With neat energy level diagram explain principle, construction & working of He-Ne laser? 8

- b) Derive condition for maxima & minima of the light reflected from a thin transparent film of uniform thickness. A parallel beam of sodium light strikes a film of oil floating on water. When viewed at an angle of 30° from normal, 9th dark band is seen. Determine the thickness of the film. Refractive index of oil is 1.46, $\lambda=5890 \text{ \AA}$. 7
- Q.4 a) Explain experimental method to determine the wavelength of spectral line using diffraction grating? 5
- b) Show that an electron cannot pre-exist in free state in a nucleus. 5
- c) Distinguish between type I & type II superconductor? 5
- Q.5 a) A diffraction grating used at normal incidence gives a yellow line ($\lambda = 6000 \text{ \AA}$) in a certain spectral order superimposed on a blue line ($\lambda = 4800 \text{ \AA}$) of next higher order if the angle of diffraction is $\sin^{-1}(3/4)$, calculate the grating element? 5
- b) Derive one dimensional time dependent Schrodinger's equation for matter waves? 5
- c) With neat diagram explain construction & working of Scanning Electron Microscope. 5
- Q.6 a) Find the de Broglie wavelength & velocity of an α particle of energy 1 keV. Given Mass of α particle = $6.68 \times 10^{-27} \text{ kg}$. 5
- b) Derive Bethe's law for electron refraction? 5
- c) What are Carbon Nano tubes? Explain properties of Nano tubes? 5

Q.P. Code :16303

[Time: Two Hours]

[Marks:60]

Please check whether you have got the right question paper.

- N.B:
1. Question.No.1 is compulsory.
 2. Attempt any three questions from remaining five questions.
 3. Figures to the right indicate full mark.
 4. All questions carry equal mark.
 5. Atomic weights :- H = 1, C = 12, N = 14, O = 16, S = 32, Cl = 35.5, Ba = 137.3 Ca = 40, Mg = 24, Na = 23

- Q.1 Answer any five from the following:- 15
- Why impure metal corrodes faster than pure metal under identical conditions?
 - What is HCV and LCV? Mention their units.
 - Give composition, properties and use of Wood's metal.
 - Define the terms: -
 - Composite materials
 - Matrix phase
 - Dispersed phase
 - Explain 'Use Catalyst, not stoichiometric reagents' principle in green chemistry.
 - State characteristics of good paints.
 - 2.2 gm coal was heated in Kjeldahl's flask and ammonia gas evolved was absorbed in 45ml of N/5 H₂SO₄. The excess acid required 35ml N/5 KOH for neutralization calculate % of Nitrogen.
- Q.2 06
- Explain the mechanism of following types of corrosion:-
 - Pitting corrosion
 - Galvanic corrosion.
 - With neat labelled diagram, explain fractional distillation of crude oil. 05
 - Calculate % Atom Economy for the following reaction with respect to Allylchloride. 04

$$\text{CH}_3 - \text{CH} = \text{CH}_2 + \text{Cl}_2 \rightarrow \text{Cl} - \text{CH}_2 - \text{CH} = \text{CH}_2 + \text{HCl}$$
- Q.3 06
- A fuel sample has the following composition: H₂ = 50% , C₂H₂ = 20% , CO = 8 % , CO₂ = 1% and rest is nitrogen. Calculate the volume of oxygen and air required for complete combustion of 5m³ of fuel. 06
 - Explain conventional and Greener route for synthesis of Indigo dye. Mention the green Chemistry principle involved. 05
 - Discuss any four factors influencing rate of corrosion. 04
- Q.4 06
- What are alloy steels? Explain heat and corrosion resisting steels. 06
 - What is the principle of cathodic protection? Explain sacrificial anodic protection method. 05
 - Explain Sandwich panel composites with suitable diagram. 04
- Q.5 06
- Write informative note on Biodiesel. 06
 - What is powder metallurgy? Explain any two methods for production of Metal powders. 05
 - Mention important applications of composite materials? 04

Q.P. Code :16303

- Q.6
- a) What are metal coatings? Mention the names of various methods of application of metallic coatings. 05
 - b) A coal sample contains, C = 80%, O = 3%, H = 7%, S = 3.5%, N = 2.1% and Ash = 4.4%. Calculate the GCV and NCV of given coal sample. 05
 - c) Write a note on 05
 - i. Atomization
 - ii. Sintering

71

[Time: Three Hours]

[Marks:60]

Please check whether you have got the right question paper.

- N.B:
1. Question No. 1 is compulsory.
 2. Attempt any three questions out of remaining five questions.
 3. Write all answers on drawing sheets only & use both the sides of the sheets.
 4. Use your own judgment for any unspecified dimension.
 5. Retain construction lines.
 6. All dimensions are in mm.

Q.1 (a) A circle of diameter 50 mm rolls without slipping along a straight horizontal line for half revolution; it slips for 25 mm and stops. Draw locus of point on the circle which is initially in contact with the directing line. Name the curve. [6]

(b) Figure-1 shows the pictorial view of an object. Draw the following views using first angle method of projection

- (i) Draw front view in the X direction [4]
- (ii) Top view [4]
- (iii) Insert all major dimensions [1]

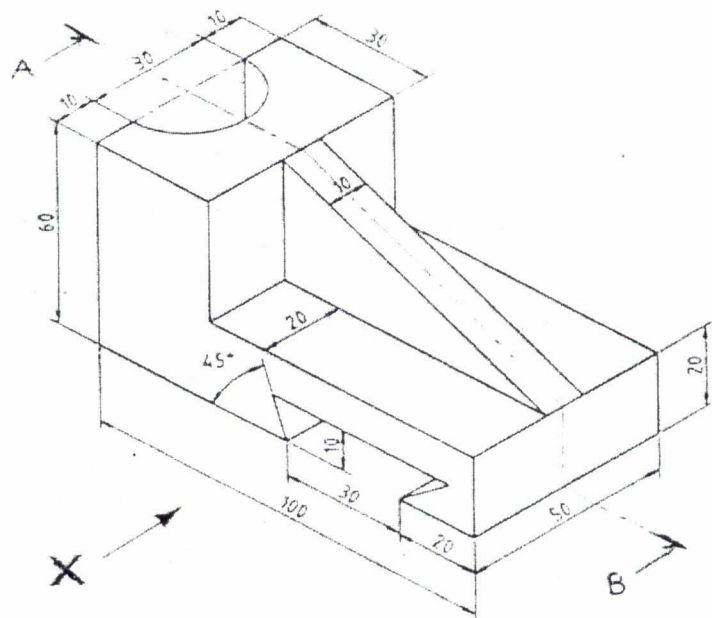

Figure-1

- Q.2 Figure-2 shows a pictorial view of machine part. Draw the following views. [5]
 (a) Sectional FV (Sect. along B-B) [4]
 (b) LHSV [4]
 (c) TV. [2]
 Insert all major dimensions

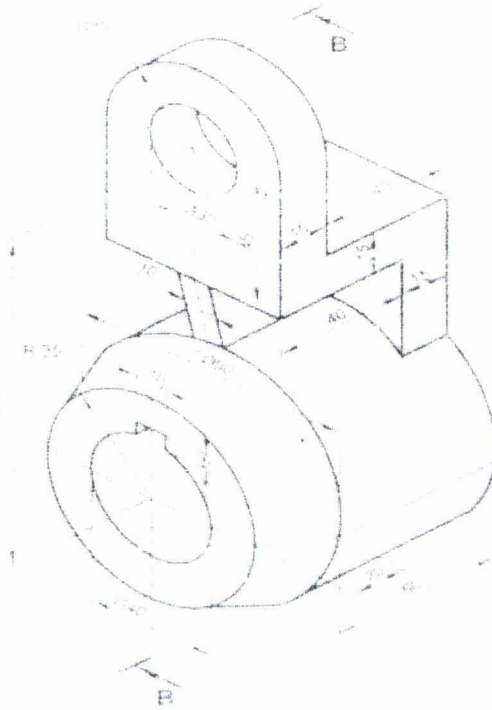

Figure-2

- Q.3 A pentagonal pyramid of 30 mm side of base and axis 60 mm long is lying on one of its triangular surface on the HP, so that top view of its axis is inclined at an angle of 45° to the VP, Draw its projection if apex is nearer to the observer [15]
- Q.4 (a) A cylinder of 50 mm diameter of base and 70 mm length of an axis is resting on one of the points of the circumference in VP. Draw its projections if one of the generators is inclined at 30° to VP. [6]

- (b) Draw the Isometric view of object of which orthographic views are as shown in Figure.-3. [9]

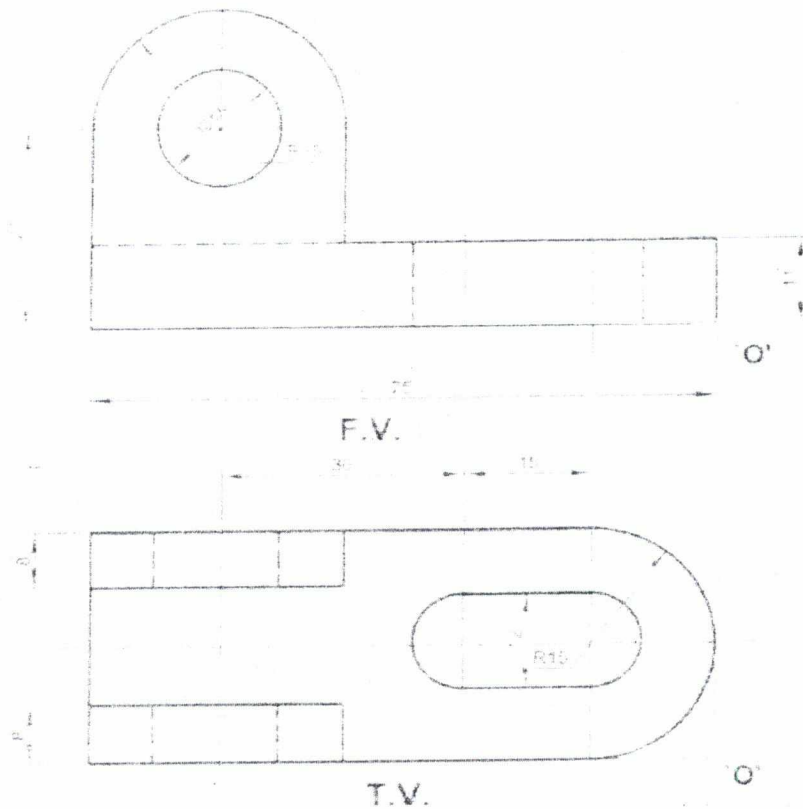

Figure-3

- Q.5 A cone of base diameter 50 mm and axis height 65 mm is resting on HP on one of its generators with axis parallel to the VP. It is cut by A.I.P. such that the true shape of the section is a parabola with the axis length equal to 60 mm. Draw the projections of cut solid & also draw development of lateral surface of remaining part of the cone (apex is removed). [15]
- Q.6 (a) A line AB 70 mm long is inclined at 30° to H.P. and 60° to V.P. Draw its projections if end A is in both HP & VP. Determine distance of end B from both the reference planes. Assume any quadrant for end B. [9]

- (b) Draw isometric projection using natural scale of object of which [6]
orthographic views are as shown in Figure.-4.

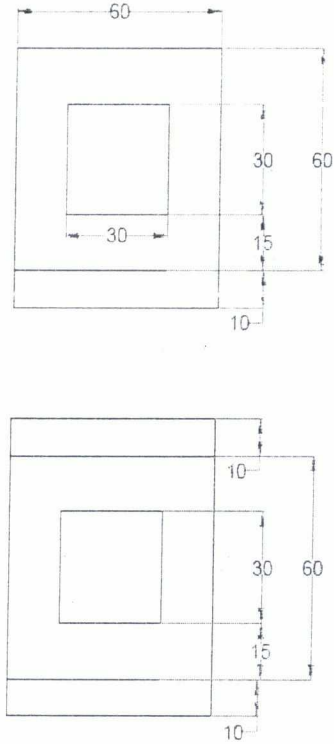

Figure-4

113

(Time: 3 hours)

[Total Marks : 80]

Please check whether you have got the right question paper.

N.B. (1) Question no. 1 is compulsory.

(2) Attempt any **three** questions from remaining **five** questions.(3) Assume **suitable data** wherever necessary.(4) Figures in **right** indicate **full** marks.

1. (a) State any two functions in string.h along with its syntax and purpose. 04
- (b) What do you mean by an algorithm and flowchart? Write an algorithm to find whether entered number is prime or not? 04
- (c) What is type-casting? Explain with an example.
- (d) Explain difference between call by value and call by reference. 04
- (e) Explain the difference between while and do-while statement. 04
2. (a) What do you mean by recursion? Write a program to reverse a number using recursive function. 10
- (b) Write a program to find largest and second largest element of an array. 10
3. (a) Write a program to calculate multiplication of two M x N matrices. 10
- (b) Write a program to generate following patterns. 10
- | | |
|------|-------|
| i> 1 | ii> A |
| 101 | CB |
| 0101 | FED |
4. (a) Explain various storage classes used in c with example. 10
- (b) (i) Write a program to find reverse of a given string without using library function. 05
- (ii) Explain nested structure with example. 05
5. (a) Explain bitwise operators in c with proper example. 05
- (b) Write a program to check whether entered no. is Palindrome or not. 05

- (c) Write a program to create an array of structure to store the details of 50 students 10
and sort and display the information of students in descending order of their
percentage. Student details include i> Roll-no.
ii> Student name
iii> Percentage
6. (a) Explain syntax of switch case. What is the need of break statement in switch case? 05
(b) Write a program to find GCD and LCM of two numbers. 05
(c) What is a file? Explain different modes with syntax in which file can be opened.
Explain various functions to read and write to a file. 10
-

04/06/2015

(REVISED COURSE)
(2 Hours)QP Code : 1062
[Total Marks : 40

N.B. (1) Question no.1 is Compulsory.

(2) Attempt any three out of the remaining FIVE questions

(3) Figures to the right indicate full marks

(4) Answers to all the sub questions should be attempted and grouped together

Q.1a. Answer any TWO of the following:

(3 x 2 = 06M)

- What steps should be taken to ensure good listening?
- How is clarity achieved in business correspondence?
- Write short note on medium with an example.
- Draw the layout of semi block form -State the punctuation applied in it.

1b. Identify the sender, message, medium and receiver in the following situations:

(04M)

- Presenting budget in the Parliament
- Announcement of man of the match after a cricket match

Q2. i. Explain semantic barriers

(02 M)

ii. Write short note on Body Language

(04 M)

iii. Complaints are blessings to the business man. Discuss.

(02 M)

iv. Define the terms: Barometer ; Laptop

(02 M)

Q3a. Maruti Merchants, Mumbai had ordered 70 bags of rice and 50 bags of Wheat from Motiwala Bros, Nasik. Write a letter of complaint for the shortage in 40 rice bags and 10 wheat bags. Give full details of the shortage and claim compensation. (Use complete block form)

(05 M)

3b. Do as directed:

1. You should first open the valve of the pipe. (Convert into an imperative sentence)

(01 M)

2. Mention the colours in which each of these is mentioned:

(02 M)

- Caution
- Warning
- Danger
- Note

3c. Write short note on signature block with an example.

(02 M)

4a. Match the following:

(02 M)

- | | |
|----------------------------|------------------------|
| i. Can cause burns | A) Semi block form |
| ii. Open punctuation | B) Warning |
| iii. Can lead to data loss | C) Complete Block form |
| iv. Indented Para | D) Caution |

JP-Con. 9345-15.

[TURN OVER

4b. State whether the following statements are True or False (02M)

- i. The quality of communication is a source of motivation and can improve human relations.
- ii. There could be no semantic barriers if all people spoke the same language.
- iii. The eyes have one language everywhere.
- iv. Socio psychological barriers can be overcome only by one's own efforts.

4c. Your housing society has 100 flats. In the General Body Meeting it has been decided to colour the buildings. As the Secretary of the society write a letter of enquiry and ask for quotation from a local consultant. (Use Semi block form) (06M)

5a. you are supposed to appear for a viva. Highlight three aspects of oral communication that you will bear in mind while answering. (03 M)

5b. Write short note on vertical communication. (03 M)

5c. Dr. Bose booked a flight ticket to attend a conference. On the day of departure he went on time to the airport as was mentioned in the ticket. , once he reached the counter he was told that the flight was rescheduled one hour early, and the passengers were informed through SMS which he did not receive because of poor network service.

- a. Identify the barriers in the given situation. (02 M)
- b. How can such situation be avoided. (02 M)

6a. Read the following passage and answer the questions given below:

Alaska pipeline starts at the frozen edge of the Arctic Ocean. It stretches southward across the largest and northernmost state in the United States, ending at a remote ice-free seaport village nearly 600 miles from where it begins. It is massive in size and extremely complicated to operate. The steel pipe crosses windswept plains and endless miles of delicate tundra that tops the frozen ground. It weaves through crooked canyons, climbs sheer mountains, plunges over rocky crags, makes its way through thick forests, and passes over or under hundreds of rivers and streams. The pipe is 4 feet in diameter, and up to 2 million barrels (or 84 million gallons) of crude oil can be pumped through it daily. Resting on H-shaped steel racks called "bents," long sections of the pipeline follow a zigzag course high above the frozen earth. Other long sections drop out of sight beneath spongy or rocky ground and return to the surface later on. The pattern of the pipeline's up-and-down route is determined by the often harsh demands of the arctic and subarctic climate, the tortuous lay of the land, and the varied compositions of soil, rock, or permafrost (permanently frozen ground). A little more than half of the pipeline is elevated above the

ground. The remainder is buried anywhere from 3 to 12 feet, depending largely upon the type of terrain and the properties of the soil. One of the largest in the world, the pipeline cost approximately \$8 billion and is by far the biggest and most expensive construction project ever undertaken by private industry. In fact, no single business could raise that much money, so 8 major oil companies formed a consortium in order to share the costs. Each company controlled oil rights and paid into the pipeline-construction fund according to the size of its holdings. Today, despite enormous problems of climate, supply shortages, equipment breakdowns, labor disagreements, treacherous terrain, a certain amount of mismanagement, and even theft, the Alaska pipeline has been completed and is operating.

1. The passage primarily discusses the pipeline's (01M)
 1. operating costs
 2. employees
 3. consumers
 4. construction
2. The word "it" in line 3 refers to (01M)
 1. pipeline
 2. ocean
 3. state
 4. village
3. According to the passage, 84 million gallons of oil can travel through the pipeline each (01M)
 1. day
 2. week
 3. month
 4. year
4. The author mentions all of the following as important in determining the pipeline's route EXCEPT the (01M)
 1. climate
 2. lay of the land itself
 3. local vegetation
 4. kind of soil and rock

5. The word "undertaken" is closest in meaning to

(01M)

1. removed
2. selected
3. transported
4. attempted

6. Which of the following determined what percentage of the construction costs each member of the consortium would pay?

(01M)

1. How much oil field land each company owned
2. How long each company had owned land in the oil fields
3. How many people worked for each company
4. How many oil wells were located on the company's land

6 b. Distinguish between oral and written communication.

(02M)

6 c. Write one word for:

(02M)

- i. One who collects postage stamps; ii. A person in charge of a museum
- iii. An instrument for detecting earthquakes; iv. A number of disorderly people

