

28

Q. P. Code: 27175

(3 hours)

Total Marks: 80

N.B. (1) Question no. 1 is Compulsory

(2) Solve any three from the remaining.

Q.1(a) If $5 \sinh x - \cosh x = 5$ find $\tanh x$. (3)(b) If $u = e^{x^2 + y^2 + z^2}$ prove that $\frac{\partial^3 u}{\partial x \partial y \partial z} = 8xyz u$. (3)(c) If $u = \frac{x+y}{1-xy}$, $v = \tan^{-1} x + \tan^{-1} y$ find $\frac{\partial(u, v)}{\partial(x, y)}$. (3)(d) By Maclaurin's series expand $\log(1+e^x)$ in powers of x upto x^4 . (3)(e) Show that the matrix $A = \frac{1}{2} \begin{bmatrix} \sqrt{2} & -i\sqrt{2} & 0 \\ i\sqrt{2} & -\sqrt{2} & 0 \\ 0 & 0 & 2 \end{bmatrix}$ is unitary and hence find A^{-1} . (4)(f) Find the n^{th} derivative of $y = \frac{x^2}{(x+2)(2x+3)}$ of (4)Q.2 (a) Solve $x^5 = 1+i$ and find the continued product of the roots. (6)

(b) Find the nonsingular matrices P and Q such that PAQ is in normal form also (6)

find the rank of A, where $A = \begin{bmatrix} 2 & 1 & 4 \\ 3 & 2 & 2 \\ 7 & 4 & 10 \\ 1 & 0 & 6 \end{bmatrix}$

(c) State and prove Euler's theorem for homogeneous functions on three variables. (8)

Q.3 (a) Investigate for what values of λ and μ the equations (6) $x + y + z = 6, x + 2y + 3z = 10, x + 2y + \lambda z = \mu$ have i) no solutions. (6)

ii) a unique solution. iii) infinite number of solutions.

(b) Find the stationary values of $f(x, y) = x^3 + xy^2 + 21x - 12x^2 - 2y^2$ (6)(c) If $\sin(\theta + i\phi) = \cos \alpha + i \sin \alpha$ Prove that $\cos^2 \theta = \sin^2 \alpha = \sinh^2 \phi$ (8)

Q. P. Code: 27175

Q.4) (a) If $z = e^{y/x} + \log(x^3 + y^3 - x^2y - xy^2)$ find the value of $\left(x \frac{\partial z}{\partial x} + y \frac{\partial z}{\partial y} + x^2 \frac{\partial^2 z}{\partial x^2} + 2xy \frac{\partial^2 z}{\partial x \partial y} + y^2 \frac{\partial^2 z}{\partial y^2} \right)$ (6)

$$x \frac{\partial z}{\partial x} + y \frac{\partial z}{\partial y} + x^2 \frac{\partial^2 z}{\partial x^2} + 2xy \frac{\partial^2 z}{\partial x \partial y} + y^2 \frac{\partial^2 z}{\partial y^2}$$

(b) Show that $\tan^{-1} i \left(\frac{x-a}{x+a} \right) = \frac{i}{2} \log \frac{x}{a}$ (6)

(c) Solve the following equations by Gauss Jordan Method

$$\begin{aligned} 2x + 3y + 4z &= 11 \\ x + 5y + 7z &= 1 \\ 3x + 11y + 13z &= 25 \end{aligned} \quad (8)$$

Q.5) (a) Find the value of a,b,c so that $\lim_{x \rightarrow 0} \frac{ae^x - (b \cos x + ce^{-x})}{x \sin x} = 2$ (6)

(b) Expand $\log(1+x+x^2+x^3)$ upto x^4 (6)

(c) If $y = \cos(m \sin^{-1} x)$ Prove that $(1-x^2)y'' - (2n+1)xy' + (m^2-n^2)y = 0$ (8)

Q.6) (a) Find a,b,c if A is orthogonal where $A = \begin{bmatrix} -8 & 4 & a \\ 1 & 4 & b \\ 4 & 7 & c \end{bmatrix}$ (6)

(b) Fit a second degree curve to the following data (6)

x	0	1	2	3	4
y	1.0	1.8	1.3	2.5	6.3

(c) If $x^3 y^2 z^2 = e$ show that the value of $\frac{\partial^2 z}{\partial x^2} - 2xy \frac{\partial^2 z}{\partial x \partial y} + \frac{\partial^2 z}{\partial y^2} = \frac{2(x^2 - 2)}{x(1 + \log x)}$, at $x=y=z$ (8)

96
FF - Sem - I - CB SGS

Q. P. Code: 27427

Time: 2 hours

Marks: 60

Note : 1. Question No. 1 is compulsory

2. Attempt any three from remaining questions.

3. Assume suitable data wherever necessary.

4. Figures to the right indicate full marks.

Q.1 Solve **any five** from the following

[15]

(a) Draw (121), (200), [121]

(b) Write values of atomic radius for SC, BCC, FCC in terms of lattice constant 'a'

(c) Why soft magnetic materials are used in core of transformers?

(d) Explain magnetostriction effect.

(e) Draw a neat labeled diagram to show variation of Fermi level with respect to temperature in n type semiconductor.

(f) For a class room of $20 \times 15 \times 15 \text{ m}^3$, the reverberation time is 3.5 sec. Calculate the total absorption of sound.

(g) Write a relation between polarization and dielectric susceptibility and the relation between dielectric susceptibility and dielectric constant.

Q.2 (a) Draw the unit cell of HCP. Derive the number of atoms / unit cell, atomic radius and APF. [8]

(b) Define Hall effect and explain its significance. With neat diagram derive the expression for the Hall voltage and Hall coefficient. [7]

Q.3 (a) Draw hysteresis loop for a ferromagnetic material. Prove that in a ferromagnetic material, the power loss/ unit volume in a hysteresis cycle is equal to the area under the loop. [4+4]

A solenoid with 500 turns carrying current 5 Amp is 0.5 m long. Calculate (i) MMF (ii) total flux. Consider area of cross section 0.0004 m^2 and air as the medium.

(b) Explain with neat circuit diagram the working of piezo electric Oscillator for generation of ultrasound. [7]

Q.4 (a) An ultra-sonic beam of wavelength 1 cm is sent from a ship and returns from sea bed after 2 seconds. If the salinity of the water is 29 gm/lit at 30°C calculate the depth of sea bed and the frequency of beam. [5]

(b) Draw the diagram representing molecular arrangement of different of different phases for the liquid crystal. State any two applications of liquid crystal. [5]

(c) The resistivity of intrinsic semiconductor is $2 \times 10^{-4} \Omega \cdot \text{cm}$. If the mobility of electron is $6 \text{ m}^2/\text{V} \cdot \text{sec}$, and that of holes is $0.2 \text{ m}^2/\text{V} \cdot \text{sec}$, calculate its carrier density. [5]

Q. P. Code: 27427

- Q.5 (a) Derive critical radius ratio for ligancy 8. [5]
- (b) The volume of a room is 600 m^3 . The wall area of the room is 220 m^2 , sound absorption coefficient for wall is 0.03, for ceiling is 0.8 and for floor is 0.06. Calculate the average sound absorption coefficient and the reverberation time. [5]
- (c) An element of crystal has density 8570 kg/m^3 . Packing efficiency 68%. determine mass of one atom if the nearest neighbor distance is 2.86 Angstrom. [5]
- Q.6 (a) Explain Ohm's law for magnetic circuit. Write at least 2 points as its comparison with electrical circuit. [5]
- (b) Explain the principle and working of solar cell. [5]
- (c) Derive Bragg's law for x ray diffraction. What data about the crystal structure can be obtained from x ray diffraction pattern? [5]



15

FE-sem-I - CBSQS - A.C - I

21/12/11

Q.P. Code: 27875

(2 Hours)

[Total Marks: 60]

- N.B. (1) Question No.1 is compulsory.
 (2) Answer any three questions from the remaining five.
 (3) All questions carry equal marks.

Atomic Weights: Ca=40, Mg=24, H=1, C=12, O=16, Cl=35.5, S=32, Na=23, Fe=55.8

Q. 1. Solve any Five:

(15)

- Define Phase with example.
- Distinguish between COD and BOD.
- Give the preparation, properties and uses of Kevlar.
- Find the Saponification value of an oil weighing 1.7 gm, reflux with 35 ml of 0.4 N KOH, required 25 ml of 0.4 N HCl for titration. The Blank reading was 35ml of 0.4N HCl.
- What are the good characteristics of refractories?
- Explain conducting polymer.
- Calculate temporary and total hardness of a sample of water containing following impurities:
 $\text{Ca}(\text{HCO}_3)_2 = 162 \text{ mg/L}$, $\text{MgCl}_2 = 23 \text{ mg/L}$, $\text{NaCl} = 58.5 \text{ mg/L}$,
 $\text{Mg}(\text{HCO}_3)_2 = 155 \text{ mg/L}$, $\text{CaCl}_2 = 111 \text{ mg/L}$.

- Q.2. (a) Calculate the amount of lime and soda (100% pure) required for softening 50,000 liters of hard water containing $\text{CaCO}_3 = 25 \text{ ppm}$, $\text{MgCO}_3 = 144 \text{ ppm}$, $\text{CaCl}_2 = 111 \text{ ppm}$, $\text{MgCl}_2 = 95 \text{ ppm}$, $\text{Na}_2\text{SO}_4 = 15 \text{ ppm}$ and $\text{Fe}_2\text{SO}_4 = 25 \text{ ppm}$. (6)
 (b) Explain one component water system with phase diagram. (5)
 (c) Write any two properties and application of CNT. (4)
- Q.3. (a) Explain any two of the following properties for lubricant with their significance (6)
- Cloud point and Pour point
 - Flash point and Fire point
 - Emulsification

(b) Why there is need of vulcanization of rubber? Give the application of Buna S rubber. (5)

(c) How many degrees of freedom are present in the following systems: (4)

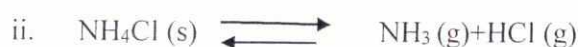

Q.P. Code: 27875

- iii. Two partially miscible liquids in absence of vapour .
- iv. $\text{Ag (s)} \rightleftharpoons \text{Ag-Pb solution (l)} + \text{Pb-Ag Vapour (g)}$

- Q.4. (a) What do you mean compounding of plastic? Explain the role of each constituent with example. (6)
- (b) Explain following (5)
- Explain role of chlorine in disinfection of water.
 - Explain reverse osmosis and give its application.
- (c) 4.6 gm of vegetable oil required 2ml of N/100 KOH during lubrication .From acid Value state whether the oil is useful for lubrication or not. (4)
- Q.5. (a) Write a note on (any two) (6)
- concrete
 - silicon carbide
 - Setting and hardening of cement
- (b) Give preparation properties and uses of PMMA and Phenol formaldehyde resin (5)
- (c) The hardness of 30,000 liters of a sample of water was completely removed (4)
by passing it through a zeolite softener .The softener then required 1500 liters of sodium chloride solution containing 234 gm/liter of NaCl for regeneration.
Calculate the hardness of the water sample.
- Q.6. (a) Explain following (6)
- Explain principle involve in EDTA method
 - Draw neat and labeled diagram for ion exchange process
- (b) Define fabrication .Explain compression moulding with labeled diagram. (5)
- (c) Distinguish between Boundary film lubrication and Thick film lubrication (4)

(3Hours)

Max. Marks : 80

N.B.1. Question No. 1 is Compulsory.

2. Answer any Three more questions out of the remaining Five questions.
3. Assume any suitable data wherever required but justify the same.
4. Figures to the right indicate full mark.
5. Take $g = 9.81 \text{ m/s}^2$

Q1a) Four forces act on a bolt as shown in fig. Find their resultant .

[4]

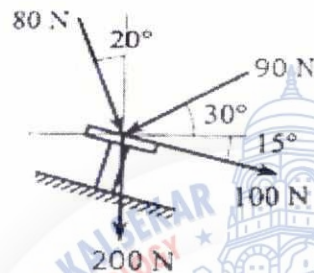

b) A roller of weight 1000N rests on a smooth inclined plane. It is kept from rolling down the plane by a string AC. Find the tension in the string and the reaction at point of contact D. [4]

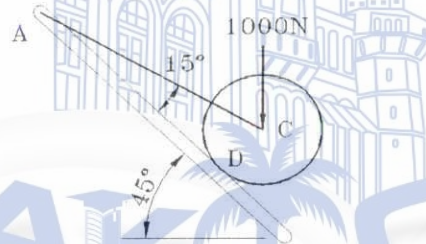

c) A block weighing 100KN is placed on rough horizontal plane. A pull force of 40KN is applied at an angle 30° on it. If the block is just on the point of moving, find the Coefficient of friction. [4]

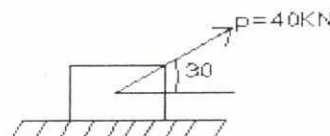

d) A point P moves along a straight line according to the equation $X = 4t^3 + 2t + 5$, [4] where X is in meters, t is in seconds. Determine the velocity & acceleration when $t=3$ sec.

Q. P. Code: 27734

e) A small block rests on a turn table, 0.7m away from its centre. The turn table, starting from rest, is rotated in such a way that the block undergoes a constant tangential acceleration. Determine the angular velocity of the turn table at the instant when the block starts slipping. $\mu=0.6$ [4]

Q2a) Three identical right circular cylinders *A*, *B* and *C*, each of weight *W* are arranged on smooth inclined surfaces as shown in the figure. Determine the least value of angle α that will prevent the arrangement from collapsing. [8]

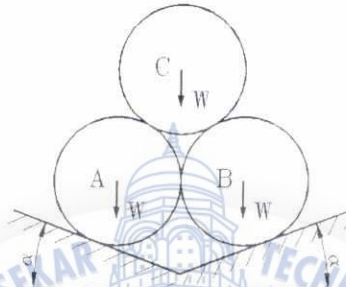

b) The forces acting on 1 m length of a dam are shown in figure. Determine the resultant force acting on the dam. Calculate the point of intersection of the resultant with the base. [6]

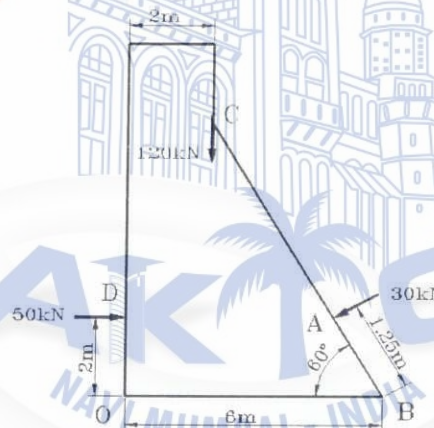

c) A boy throws a ball vertically downwards from a height of 1.5m. He wants to rebound it from floor and just touch the ceiling of room which is at a height of 4m from ground. If coefficient of restitution is 0.8. find the initial velocity with which the ball should be thrown. [6]

Q. P. Code: 27734

Q3.a) Determine the Centroid of the shaded area. All dimensions are in mm. [8]

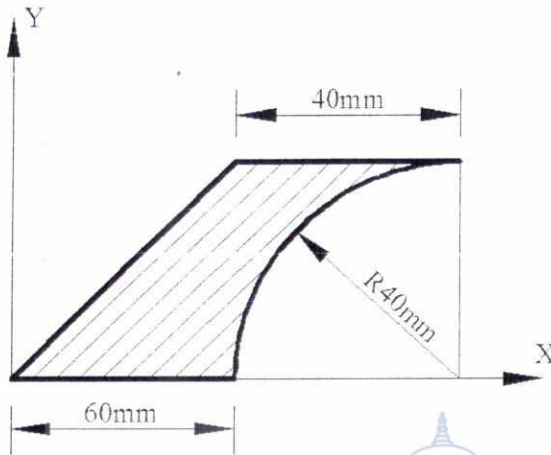

b) Determine the resultant force and resultant moment about point A (3,1,2) of the following force system.

$F_1 = (5i + 8k)$ N acting at point B (8,3,-1) m.

$F_2 = (3i + 2j - 4k)$ N acting at origin.

$M = (12i - 20j + 9k)$ N m. [6]

c) A cylinder has mass 20 kg and is released from rest, when $h = 0$. Determine the speed when $h = 3$ m. The spring has an un-stretched length of 2 m. [6]

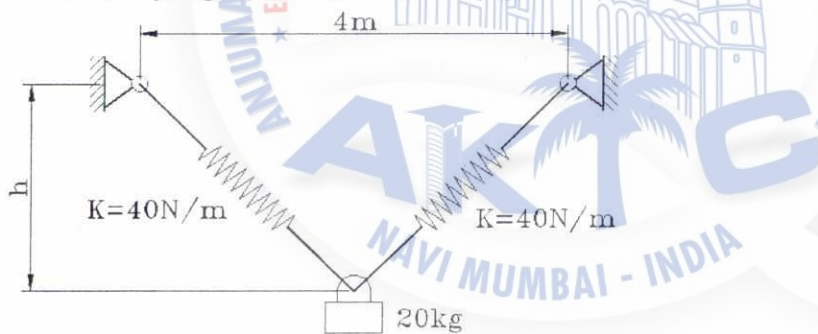

Q4.a) Find support reactions at A and B for the beam loaded as shown in figure. A is hinged and B is roller. [8]

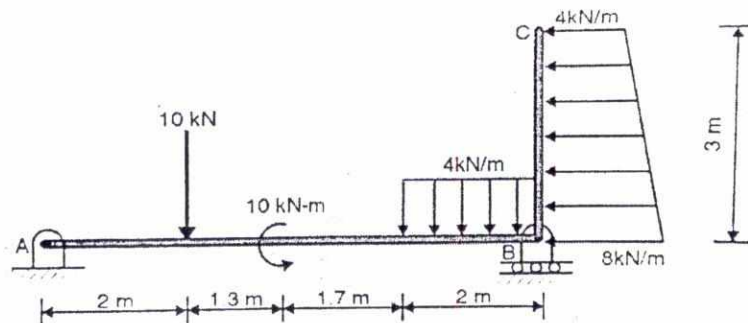

Q. P. Code: 27734

- b) A particle is projected from the top of a tower of height 50 m with a velocity of 20 m/sec at an angle 30 degree to the horizontal. Determine
- Horizontal distance AB it travel from the foot of the tower
 - The velocity with which it strikes the ground at B.
 - Total time taken to reach point B

[6]

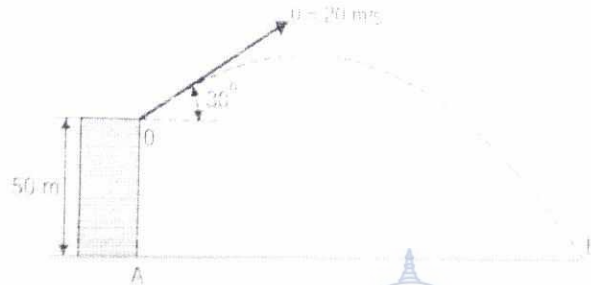

- c) Velocity of point A on rod is 20 m/s at the instant shown in figure. Locate ICR for the rod and determine velocity of point B on the rod.

[6]

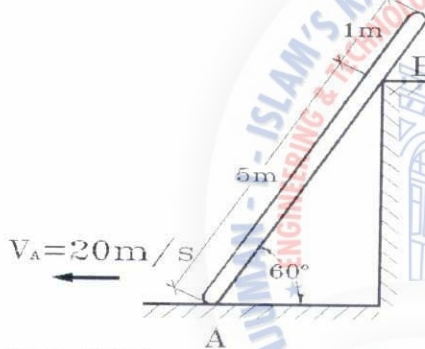

- Q5a) Find the magnitude and nature of forces in members BD, BE and CE of the truss by method of sections and other members by method of joints. Support at A is hinged and support at B is roller.

[8]

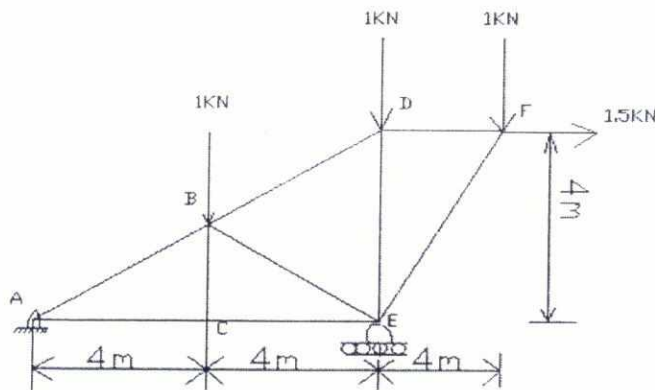

Q. P. Code: 27734

b) Figure below shows a plot of $a-t$ graph for a particle moving along a straight line. Draw $v-t$ graph from 0 to 50 seconds and determine distance covered by the particle at $t=50$ seconds.

[6]

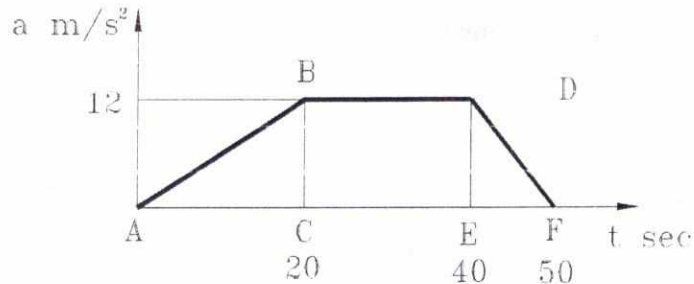

c) A slider crank mechanism is shown in fig. The crank OA rotates anticlockwise at 100 rad/s . Find the angular velocity of rod AB & the velocity of the slider at B.

[6]

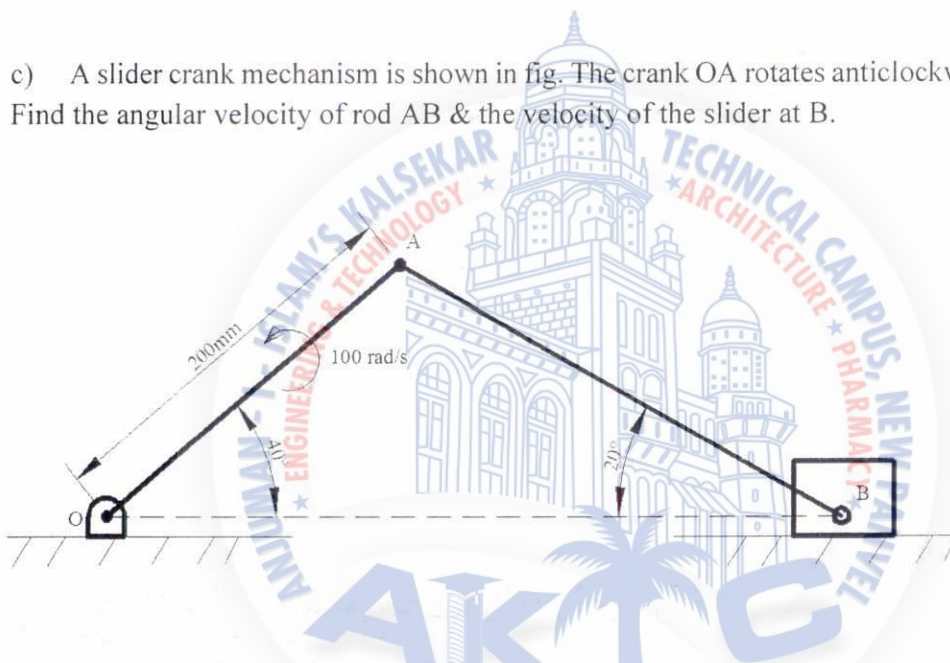

Q6a) Two blocks A & B of weight 500 N & 750 N resp. are connected by a cord that passes over a frictionless pulley as shown in fig. the coefficient of friction between the block A & the inclined plane is 0.4 & that between the block B & the inclined plane is 0.3 . Determine the force P to be applied to block B to produce the impending motion of block B down the plane.

[8]

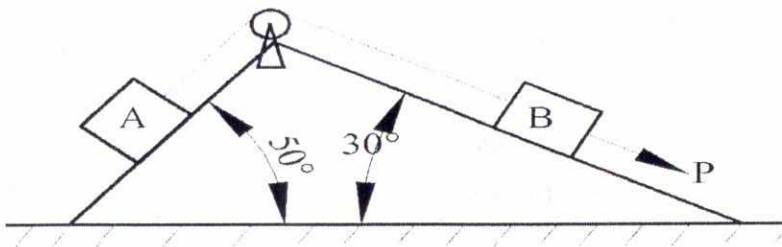

Q. P. Code: 27734

- b) Write down the conditions of equilibrium for Forces in Space for
(i) con-current force system (ii) general force system . [4]
- c) A car starts from rest and moves along a circular path having a radius of 20m. Its speed increases at a uniform rate of 0.5 m/s^2 . Find the time from the start and distance travelled when its resultant acceleration becomes 1.5 m/s^2 . [4]
- d) Two masses of 5kg & 2kg are positioned over frictionless & mass less pulley as shown in fig. If the 5kg mass is released from rest, determine the speed at which the 5kg mass will hit the ground. [4]



Q. P. Code: 25774

TOTAL MARKS: 80

TIME: 3hrs

NB

- 1) Question No. 1 is compulsory.
- 2) Answer any three questions out of remaining five questions.
- 3) Assumption made should be clearly stated.
- 4) Answer to questions should be grouped together and written together.

Q1 a. Find current through ammeter

3

b. Find the current through $3\ \Omega$ resistor using source transformation

3



- c. Two voltage sources have equal emfs and phase difference α . When they are connected in series the voltage is 200 V. When one source is reversed the voltage is 15 V. Find their emfs and phase angle. 3
- d. Derive the equation of resonance frequency of a R-L-C series resonance circuit. What will be the power factor under this condition? 3
- e. Draw power triangle for a three phase balanced inductive load and mark its all sides along with units 2
- f. Derive the emf equation of a single phase transformer. 4
- g. Draw the input and output voltage waveform of a full wave rectifier. 2

Q2 a. Using Nodal analysis find current through $6\ \Omega$ resistor.

6



[TURN OVER

Q. P. Code: 25774

- b. Find current through Z_1 and total current. Also calculate the power and power factor of the entire circuit and supply voltage. 8

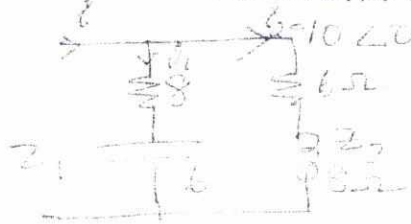

- c. Draw phasor diagram of a single phase transformer connected to a resistive load. 6
- Q3 a. The circuit shown in figure is supplied by a 240 V, three phase, 4 wire system. 8



1. Determine line and phase currents
 2. Draw neat phasor diagram showing the relationship between phase and line quantities.
 3. Is the system balanced or not justify
 4. Find active power, reactive power and apparent power
- b. A 5 kVA, 100/400 V, 50 Hz single phase transformer gave the following test results. 6
- Open circuit test(L.V side): 100 V, 0.7 A, 60 W
 Short circuit test(H.V side): 22 V, 16A, 120 W
 Draw equivalent circuit referred to LV side
- c. With neat circuit diagram and characteristics explain the input and output characteristics of a CE transistor configuration. 4
- d. Draw the circuit diagram and output voltage waveform of a full wave center tapped rectifier with capacitor filter. 2

[TURN OVER

Q. P. Code: 25774

- Q4 a. Find current through $20\ \Omega$ using Thevenin's Theorem. 7

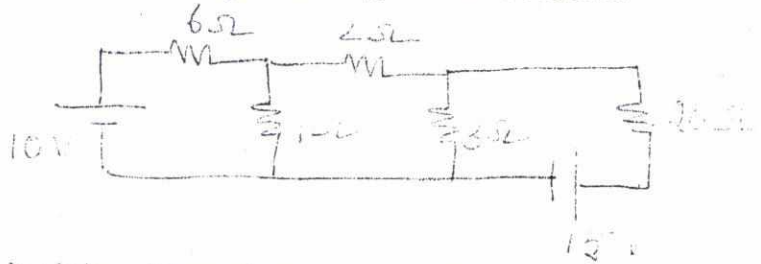

- b. In a balanced three phase star connected circuit power is measured by two wattmeter. Draw circuit diagram indicating clearly the wattmeter connection and the phasor diagram 4
- c. An alternating current is given by 5
 $i(t) = 300\sin(50\pi t + \frac{\pi}{3})$
 What is the maximum value of current, frequency and time period? What is the rms value and average value of this equation.
- d. Derive rectification efficiency and ripple factor of a full wave bridge 4 rectifier.
- Q5 a. Calculate the load resistance which can abstract maximum power and also 8 calculate the maximum power.

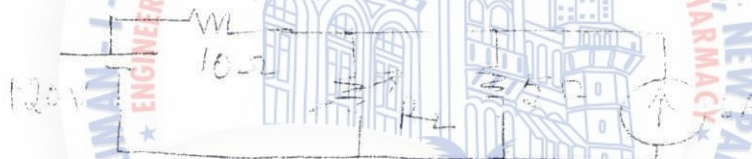

- b. Current flowing through an inductive circuit is 4
 $i(t) = 15\sin(\omega t + \frac{\pi}{4})$ when the voltage across it is $30\cos\omega t$ find the power factor of the circuit
- c. Develop complete equivalent circuit of a single phase transformer 8
- Q6 a. Find current through $10\ \Omega$ resistor using superposition theorem. 7



[TURN OVER

Q. P. Code: 25774

- b. A coil of resistance 2Ω and inductance of 0.07 H . Calculate the capacitance of a capacitor required to produce resonance when connected in parallel with the coil across a 230 V , 50 Hz supply. What is the Q factor and current? 7
- c. Two wattmeters are connected to measure power in a three phase circuit. The reading of one wattmeter is 7 kW when load power factor is unity. If the power factor of the load is changed to 0.707 lagging without changing the total input power, calculate the reading of two wattmeters 6



Please check whether you have got the right question paper.

- N.B:
1. Question number 1 is compulsory.
 2. Attempt any three question from Q.2 to Q.6.
 3. Draw neat labelled diagrams wherever necessary.
 4. Figures to right indicate full marks.

- Q.1** Attempt any five questions from following;- 15
- a) What are the reasons for depletion of mineral resources?
 - b) Explain the term: - 'sustainable development'.
 - c) What cause noise pollution? Why it is bad?
 - d) What are the powers of 'State Pollution Control Board' (SPCB)?
 - e) Explain working principle of photovoltaic cells.
 - f) Write effects produced by any three indoor air pollutants.
 - g) What adverse effects are caused due to depletion of ozone layer?
- Q.2**
- a) Explain in detail any one control measure which can be adopted for better sustainable development. 5
 - b) How solid waste management can be achieved through landfilling. 5
 - c) Draw neat labelled diagram and explain generation of electricity from geothermal energy. 5
- Q.3**
- a) Why acid – rain is considered as bad? How it is formed? 5
 - b) Describe important features of 'Environmental Protection Act'. 5
 - c) How disaster management techniques are useful in the event of earthquake. 5
- Q.4**
- a) What are the global problems pertaining to population? 5
 - b) When environmental consent is required to be taken? Why it is important? 5
 - c) Draw a suitable diagram and explain how hydropower is generated? 5
- Q.5**
- a) Write social and economic aspects related to sustainable growth. 5
 - b) Draw a neat labelled diagram and explain working of bag house filter. Also, explain the role played by it in pollution control. 5
 - c) Draw neat diagram of wind mill and explain its role in converting wind energy into electricity. 5
- Q.6**
- a) How environmental awareness is required for prevention of environmental degradation? 5
 - b) How industrial waste water treatment is carried out? 5
 - c) Explain the role of technology in improving environment and human health. 5

