

FE - sem - II - Choice Based - AM - II
(CBCS)

Q.P. Code : 16282

Max. Marks: 80

Time: 3 hrs.

N.B. : 1. Q1 is compulsory

2. Attempt any three questions from Q2 to Q6.

Q1. a) Evaluate $\int_0^{\infty} \frac{e^{-x^2}}{\sqrt{x}} dx$ 3

b) Solve $(D^3 + 1)^2 y = 0$ 3

c) Solve the ODE $\left(y + \frac{1}{3}y^3 + \frac{1}{2}x^2\right) dx + (x + xy^2) dy = 0$ 3

d) Use Taylor's series method to find a solution of $\frac{dy}{dx} = 1 + y^2$, $y(0) = 0$ 3
at $x = 0.1$ taking $h = 0.1$ correct to three decimal value.

e) Given $\int_0^x \frac{dx}{x^2 + a^2} = \frac{1}{a} \tan^{-1}\left(\frac{x}{a}\right)$, using DUIS find the value of $\int_0^x \frac{dx}{(x^2 + a^2)^2}$ 4

f) Find the perimeter of the curve $r = a(1 - \cos\theta)$. 4

Q2. a) Solve $(D^3 + D^2 + D + 1)y = \sin^2 x$ 6

b) Change the order of integration $\int_0^a \int_{\sqrt{a-x}}^{x+3a} f(x, y) dx dy$ 6

c) Evaluate $\iint_R \frac{2xy^5}{\sqrt{1+x^2y^2-y^4}} dx dy$, where R is a triangle whose vertices 8
are $(0, 0), (1, 1), (0, 1)$.

Q3. a) Find the volume enclosed by the cylinder $y^2 = x$ & $y = x^2$ 6
cut off by the planes $z = 0, x + y + z = 2$.

b) Using Modified Euler's method, find an approximate value of y at 6
 $x = 0.2$ in two step taking $h = 0.1$ and using three iteration, given that
 $\frac{dy}{dx} = x + 3y$, $y = 1$ when $x = 0$.

c) Solve $(1+x)^2 \frac{d^2y}{dx^2} + (1+x) \frac{dy}{dx} + y = 4 \cos \log(1+x)$ 8

Q4. a) Show that $\int_0^a \frac{\sqrt{x^3}}{\sqrt{a^3-x^3}} dx = \frac{a\sqrt{\pi} \Gamma(\frac{2}{3})}{\Gamma(\frac{1}{3})}$ 6

b) Solve $(D^2 + 2)y = e^x \cos x + x^2 e^{3x}$ 6

c) Use polar co-ordinates to evaluate $\iint \frac{(x^2 + y^2)^2}{x^2 y^2} dx dy$ over the area 8
common to the circle $x^2 + y^2 = ax$ and $x^2 + y^2 = by$, $a > b > 0$.

Q5. a) Solve $y dx + x(1 - 3x^2 y^2) dy = 0$ 6

b) Find the mass of a lamina in the form of an ellipse $\frac{x^2}{a^2} + \frac{y^2}{b^2} = 1$, if the 6
density at any point varies as the product of the distance from the axes of the ellipse.

c) Compute the value of $\int_0^{\pi/2} \sqrt{\sin x + \cos x} dx$ using (i) Trapezoidal rule 8
(ii) Simpson's (1/3)rd rule (iii) Simpson's (3/8)th rule by dividing into six subintervals.

Q6. a) Evaluate $\iiint_V x^2 dx dy dz$ over the volume bounded by the planes 6
 $x = 0, y = 0, z = 0$ and $\frac{x}{a} + \frac{y}{b} + \frac{z}{c} = 1$

b) Change the order of integration and evaluate $\int_0^2 \int_{\sqrt{2y}}^2 \frac{x^2}{\sqrt{x^2 - 4y^2}} dx dy$ 6

c) Solve by the method of variation of parameters $\frac{d^2 y}{dx^2} - 6 \frac{dy}{dx} + 9y = \frac{e^{3x}}{x^2}$ 8

97

FE - Sem-II - Choice based - A.P-II

24/11/17

Q.P. Code :09911

[Time: 2 Hours]

[Marks:60]

Please check whether you have got the right question paper.

- N.B:**
1. Question no 1 is compulsory
 2. Attempt any three questions from Q.2 to Q.6.
 3. Use suitable data wherever required
 4. Figures to the right indicate full marks.

- Q.1** Attempt **any five** of the following. 15
- A Why the Newton's rings are circular and centre of interference pattern (reflected) is dark?
- B What is Rayleigh's criterion of resolution? Define resolving power of a grating?
- C Calculate the V number of an optical fibre having numerical aperture 0.25 and core diameter $20 \mu\text{m}$, if its operating wavelength is $1.55 \mu\text{m}$
- D What is pumping in LASER? Give the types of pumping.
- E Show that the divergence of the curl of a vector is zero.
- F Determine the magnetic field required to bend a beam consisting of electrons of speed $3 \times 10^7 \text{m/s}$ in a circle of radius 5 cm.
- G What will be the fringe pattern if wedge shaped air film is illuminated with white light?
- Q.2A** Obtain the condition for maxima and minima of the light reflected from a thin transparent film of uniform thickness. Why is the visibility of the fringe much higher in the reflected system than in the transmitted system? 08
- B** What is Numerical aperture? Explain the use of optical fibre in temperature sensor. 07
The core diameter of a multimode step index fibre is $50 \mu\text{m}$. The numerical aperture is 0.25. Calculate the number of guided modes at an operating wavelength of $0.75 \mu\text{m}$.
- Q.3A** Explain the experimental method to determine the wavelength of spectral line using diffraction grating. 08
A diffraction grating has 5000 lines /cm and the total ruled width is 5cm. Calculate dispersion for a wavelength of 5000\AA in the second order.
- B** Explain construction and working of Nd: YAG laser. 07
- Q.4A** Explain Spherical co-ordinate system. State the transformation relation between Cartesian and Spherical coordinates. 05
- B** Explain construction and working of cathode ray tube. 05
- C** A wedge shaped air film having angle of 40 seconds is illuminated by monochromatic light. Fringes are observed vertically through a microscope. The distance between 10 consecutive dark fringes is 1.2cm. Find the wavelength of monochromatic light used. 05
- Q.5A** With neat diagram explain construction and working of Atomic force microscope. 05
- B** Derive Maxwell's two general equations in integral and differential form. 05
- C** An electron is accelerated through a potential difference of 5 kV and enters a uniform magnetic field of 0.02wb/m^2 acting normal to the direction of electron motion. Determine the radius of the path. 05
- Q.6A** What are different techniques to synthesis nonomaterial? Explain one of them in detail. 05
- B** What is holography? Differentiate between holography and photography. 05
- C** Describe in detail the concept of anti reflecting film with a proper ray diagram. 05

45

FE-sem-III- Choice based - A-C-II

30/11/17

Q.P. Code :13125

[Time: Two Hours]

[Marks:60]

Please check whether you have got the right question paper.

- N.B:
1. Question.No.1 is compulsory.
 2. Attempt **any three** questions out of remaining five.
 3. Figures to the right indicate full marks.
 4. Atomic weights:- C=12, S=32, N=14,H=1,O=16,Cl=35.5

1. Answer **any five** from the following 15
 - a) Select the compound which possesses highest octane number and highest cetane number out of n-heptane, n- octane and isooctane.
 - b) Iron does not rust even if the zinc coating is broken in a galvanized iron pipe. Give reasons.
 - c) Calculate the higher and lower calorific values of coal sample containing 84% carbon, 1.5% sulphur, 0.6 Nitrogen, 5.5% hydrogen and 8.4% oxygen.
 - d) What are the drawbacks of plain carbon steel.
 - e) Explain the principle 'Prevention of waste' in Green Chemistry.
 - f) Define and classify composite materials.
 - g) Mention three functions of thinner in paint.
2.
 - a) Define corrosion of metals. Explain the electrochemical theory of wet corrosion, giving its mechanism. 6
 - b) i) 1.56 g of a coal sample was kjeldahlised and NH_3 gas thus evolved was absorbed in 50ml of 0.1N H_2SO_4 . After absorption the excess (residual) acid required 6.25 mL of 0.1N NaOH for exact neutralization. Calculate the percentage of N in the coal sample. 3
 ii) What is super critical CO_2 ? Why is it considered a green solvent 2
 - c) Write a short note on Particle reinforced composites. 4
3.
 - a) What is cracking? Explain in detail –fixed bed catalytic cracking. 6
 - b) i) Write a brief note on Heat resistant steel 3
 ii) A metal rod half immersed in water starts corroding at the bottom. Give reasons. 2
 - c) Calculate the percentage atom economy for the following reaction with respect to allyl chloride. 4
 $\text{CH}_3\text{-CH=CH}_2 + \text{Cl}_2 \rightarrow \text{Cl-CH}_2\text{-CH=CH}_2 + \text{HCl}$
 Allylchloride.
4.
 - a) Explain how the following factors affect the rate of corrosion 6
 - i) pH
 - ii) Ratio of anode to cathode areas
 - iii) Position of metal in galvanic series.

Q.P. Code :13125

- b) i) Write a brief note on products obtained from natural materials 3
ii) Define structural composites. 2
- c) Define Shape memory Alloys and mention its applications (at least four) 4
- 5.
- a) A sample of coal was found to contain the following constituents. C=81%; O=8% S=1%; H=5%, N=1% and Ash=4% 6
Calculate the minimum weight and volume of air required for the complete combustion of 1kg of coal.
- b) i) Discuss in brief sacrificial anode method of corrosion protection. 3
ii) What is powder metallurgy? Mention any two advantages and two limitations of powder metallurgy 2
- c) Explain with suitable equations conventional and green synthesis of carbaryl. Also mention the principle of green chemistry involved. 4
- 6.
- a) Mention the composition, properties and uses of (Any two) 6
i) Duralumin
ii) German silver
iii) Gun metal
- b) i) Mention the advantages of composite materials 3
ii) Distinguish between anodic and cathodic coating 2
- c) What is biodiesel? Discuss the method to obtain biodiesel. What are the advantages of biodiesel? 4

Q. P. Code: 27855

(3 Hours)

[Total Marks: 60]

N. B. - 1. Attempt any four questions.

2. Use first angle method of projection, unless mentioned otherwise.

3. Write all answers on drawing sheets only & use both the sides of the sheets.

4. Use your own judgment for any unspecified dimension.

5. Retain construction lines.

6. All dimensions are in mm.

Q.1 (a) An inelastic string 100 mm long is wound around a disc of 40 mm diameter. (06)
Trace the path of free end of a string and name the curve.

(b) For the object shown in figure draw the following views -

(i) Front view in the direction of arrow X. (05)

(ii) Top view. (04)

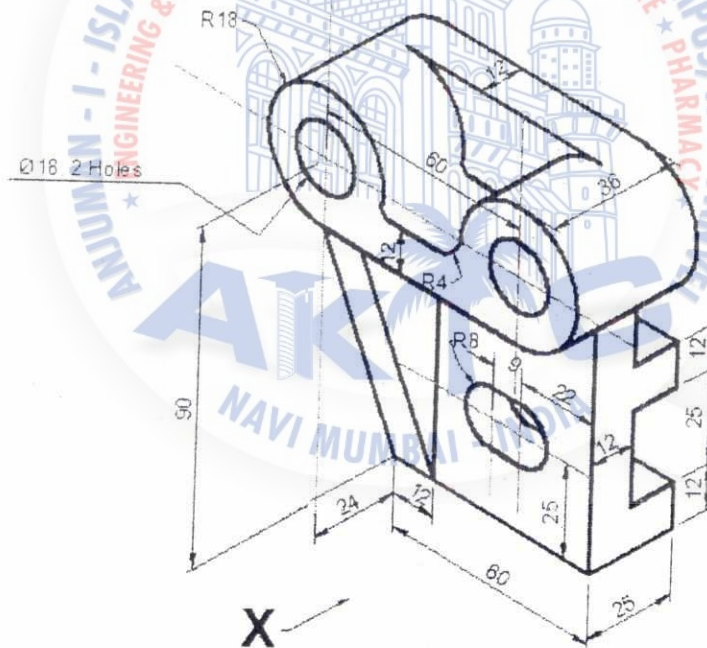

Q. P. Code: 27855

Q. 2

For the object shown in figure draw the following views -

- (i) Sectional front view along section A-A. (04)
 (ii) Side view from left (04)
 (iii) Top view (05)
 (iv) Insert the major dimensions (02)

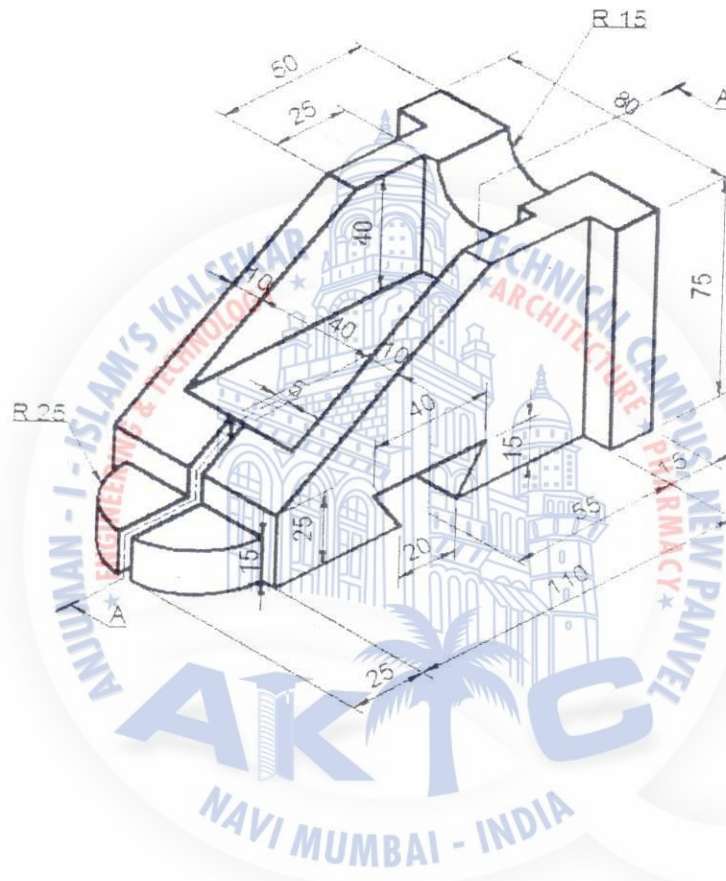

Q. 3

A square pyramid side of base 40 mm and axis length 60 mm has one of its side (15)
 of base in the HP. The axis of the solid is inclined to the HP at an angle 30° and
 top view of the axis is inclined at an angle 45° with the VP. Draw its projections
 when the apex is away from the observer.

Q. 4 (a)

A right circular cylinder diameter of base 50 mm and axis height 70 mm has one (06)
 of the circumference point of base in the HP, such that its axis is inclined at 30°
 to the HP. Draw its projections.

Q. P. Code: 27855

Q. 4 (b) Figure shows two views of an object. Draw its isometric view. (09)

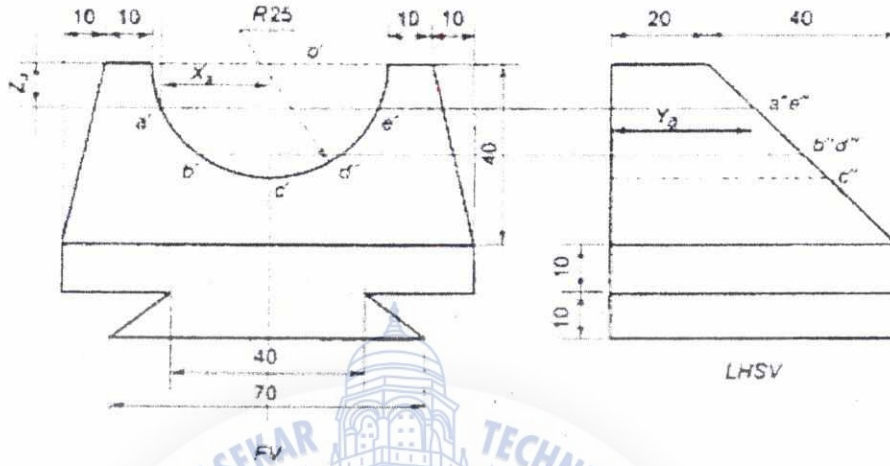

Q. 5 A cone of base 70 mm diameter and axis 90 mm long is resting on its base on HP. It is cut by a section plane perpendicular to the VP and parallel to and 15 mm away from one of its end generators. Draw the sectional top view, front view & sectional side view. Also draw the true shape of the section. Also draw development of the lateral surface of the cone. (15)

Q. 6 (a) A straight line PQ has its end point P 10 mm above HP and 15 mm in front of the VP. The line is 50 mm long & its front and top views are inclined at an angle of 60° & 45° respectively. Draw the projections of the line PQ and find its inclinations with the HP & VP. (09)

(b) Figure shows two views of an object. Draw its isometric view with 'O' as origin. (06)

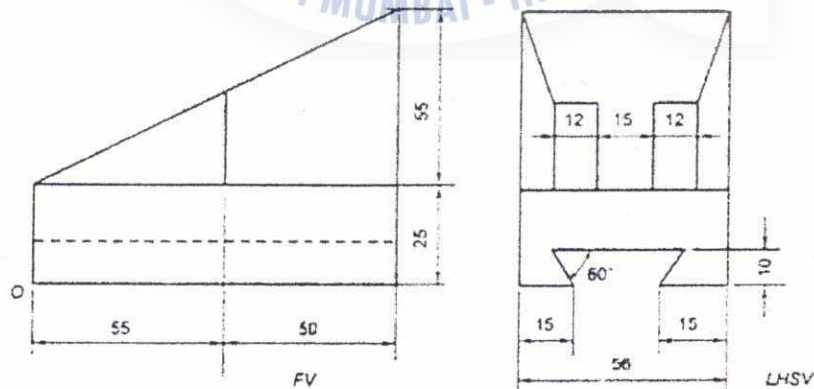

95

FE-sem-II - choice Based - SPA

8/12/17

Q.P CODE: 23993

TOTAL MARKS: 80

DURATION: 3HRS

- N.B: 1. Question No. 1 is compulsory.
 2. Answer any three out of remaining five questions.
 3. Figures to right indicates full marks
 4. Assume suitable data if necessary and state them clearly

- Q1. a) Define union. Compare structure and union. 4
 b) What is an error? Explain different types of errors occurred in program. 4
 c) Explain switch case and if-else ladder with example 4
 d) Explain any four standard library functions from string.h. 4
 e) Explain break and continue statement with example. 4
- Q2. a) Define Algorithm. Write Algorithm to check whether given number is armstrong Numbers or not also mention input and output specifications to algorithm. 10
 b) Explain various storage classes with example. 10
- Q3. a) Explain Nested Structure. Write a program using nested structure to create an Array of structure to store the details of N students. 10
 The details are,
 1. Student name
 2. Student Roll no
 3. Marks of Physics, Chemistry, Maths.
 Calculate the total of P-C-M. Display the data in the format
 Name Roll no Total marks
- b) Define pointer and its use. Explain array of pointer with example. Write program to swap to values by using call by reference concept. 10
- Q4. a) Explain recursive function. Write a program to find the GCD of a number by Using recursive function. 10
 b) Write a program to perform matrix multiplication by passing input matrix to the function And printing resultant matrix. 10
- Q5. a) Write a program to display following pattern: 5
- ```

1
2 3 2
3 4 5 4 3
4 5 6 7 6 5 4
5 6 7 8 9 8 7 6 5

```

## Q.P CODE: 23993

- b) Write user defined function to implement string concatenation. 5
- c) Explain need of file data and various modes of files also write program to create and edit copy of file 10
- Q6. a) Write a program to sort the given array in ascending order. 10
- b) Write a program for finding sum of series,  $1+2+3+4+\dots$  upto n terms. 5
- c) Draw the flow chart to find roots of a quadratic Equation. 5

\*\*\*\*\*



Q.P.Code: 24723

(2 Hours)

Total Marks: 40

N.B.(1) Question No.1 is compulsory.

(2) Attempt Any three out of five questions.

Q. 1 a) Write a short on objectives of communication. (3)

b) Read each sentence and fill the blank spaces choosing the correct articles in it. (2)

1. Are you coming to ----- party next Saturday?

2 She was wearing True ----- ugly dress when she met him.

c) Write short note on modified block format with its diagrammatic representation. (3)

d) Construct the technical definition of the following. (2)

1) Electric Bell 2) Clinical thermometer

Q. 2. a) Explain seven C's of effective written communication. (3)

b) Explain merits of oral communication. (2)

c) As the Purchase Manager of Elixir society, you have ordered some computers and scanners for your office to Global systems limited. Which you had ordered from them has reached you in a damaged condition. Make a Complaint to company and demand replacement or suitable compensation. Invent necessary details. (Use Complete Block form) (5)

Q. 3. A) Write a short on chronemics (Temporal). (3)

b) Match the following (2)

A

- 1) Full Block form
- 2) Letterhead
- 3) Demanding for compensation
- 4) Open punctuation

B

- a) claim letter
- b) Body of letter is punctuated
- c) No indents
- d) Logo

c) You have opened new shop stationary in node of your city. Write a letter of enquiry for different items for your shop from whole sale dealer from Mumbai. Mention all details regarding different varieties, colour, quality and prices etc which you need for your shop. (Use Modified Block) (5)

Q.4. a) write short note on qualities of Good Speaker. (2)

b) Write a short on following concepts. (6)

1. Significance of feedback

2. Your attitude

Turn Over

c) Identify the barrier. (2)

1. He is sat on bank
2. "Everything is wrong in this company".

Q.5 . a) Explain in detail cultural barriers. (3)

b) Provide one word substitute for the following sentence. (Any two) (4)

1. One who copies from other writers, literary theft.
2. One who does a thing for pleasure and not as a profession.
3. A place where ships seek shelter

c) State the difference between warning and caution. (3)

Q.6. a) Describe any ONE of the following objects giving definition, diagram, components and working of Calculator or voltmeter (5)

b) Read the following passage carefully and answer the questions given below. (5)

The New Year is the time for resolution. Mentally, at least most of us could compile formidable lists of 'do's and 'don'ts'. The same old favorites recur year in and year out with the children, do a thousand and one job about the house, be nice to people we don't like, drive carefully, and take the dog for a walk every day. Past experience has taught us that certain accomplishments are beyond attainment. If we remain deep rooted liars, it is only because we have so often experienced the frustration that results from failure.

Most of us fail in our efforts at self improvement because our schemes are too ambitious and we never have time to carry them out. We also make the fundamental error of announcing our resolution to everybody so that we look even more foolish when we slip back into our bad old ways. Aware of these pitfalls, this year I attempted to keep my resolution to myself. I limited myself to two modest ambitions, to do physical exercise every morning and to read more in the evening. An overnight party on New Year's Eve provided me with a good excuse for not carrying out either of this new resolution on the first day of the year, but on the second, I applied myself assiduously to the task.

The daily exercise lasted only eleven minutes and I proposed to do them early in the morning before anyone had got up. The self discipline required to drag myself out of bed eleven minutes earlier than usual was considerable. Nevertheless, I managed to creep down into the living room for two days before anyone found me out. After jumping about in the carpet and twisted the human frame into uncomfortable positions. I sat down at the breakfast table in an exhausted condition. It was this that betrayed me. The next morning the whole family trooped into watch the performance. That was really unsettling but I fended off the taunts and jibes of the family good humouredly and soon everybody got

Turn Over

used to the idea. However, my enthusiasm waned, the time I spent at exercises gradually diminished. Little by little the eleven minutes fell to zero. By January 10th I was back to where I had started from. I argued that if I spent less time exhausting myself at exercises in the morning, I would keep my mind fresh for reading when I got home from work. Resisting the hypnotizing effect of television, I sat in my room for a few evenings with my eyes glued to a book. One night, however, feeling cold and lonely, I went downstairs and sat in front of the television pretending to read. That proved to be my undoing, for I soon got back to the old bad habit of dozing off in front of the screen. I still haven't given up my resolution to do more reading. In fact, I have just bought a book entitled 'How to Read a Thousand Words a Minute'. Perhaps it will solve my problem, but I just have not had time to read it.

- Q.1. why most of us fail in our efforts for self-improvement?
- Q.2. Why is it a basic mistake to announce our resolution to everybody?
- Q.3. Why did the writer not carry out his resolution on New Year's Day
- Q.4. Find out the words in the above passage which convey the similar meaning to the following: (1) Overwhelming (2) Drawbacks
- Q.5. Give suitable title for passage

