



School of Architecture

School of Engineering & Technology

School of Pharmacy

Knowledge Resource & Relay Centre (KRRC)

AIKTC/KRRC/SoET/ACKN/QUES/2017-18/

Date: _____

School: SoET-CBCS

Branch: ALL BRANCHES

SEM: II

To,
Exam Controller,
AIKTC, New Panvel.

Dear Sir/Madam,

Received with thanks the following Semester/Unit Test-I/Unit Test-II (Reg./ATKT) question papers from your exam cell:

Sr. No.	Subject Name	Subject Code	Format		No. of Copies
			SC	HC	
1	Applied Mathematics- II	FEC201		✓	
2	Applied Physics- II	FEC202		✓	
3	Applied Chemistry- II	FEC203		✓	
4	Engineering Drawing	FEC204		✓	
5	Structured Programming Approach	FEC205		✓	
6	Comm. Skills- II	FEC206		✓	

Note: SC – Softcopy, HC - Hardcopy

(Shaheen Ansari)
Librarian, AIKTC

456

FE-SEM-II - Choice Based - AM-II

15/5/1

Q. P. Code: 36997

Total Marks: 80

Hours: 3 hrs

- Note: 1. Question no. 1 is compulsory.
2. Attempt any three questions out of remaining five questions.

Q.1. [a] Evaluate $\int_0^{\infty} 5^{-4x^2} dx$. [3]

[b] Solve $\frac{dy}{dx} = xy$ with the help of Euler's method, given that $y(0) = 1$, and find y when $x = 0.3$ ($h = 0.1$). [3]

[c] Evaluate $\frac{d^4y}{dx^4} + 2\frac{d^2y}{dx^2} + y = 0$. [3]

[d] Evaluate $\int_0^1 \sqrt{\sqrt{x} - x} dx$. [3]

[e] Solve $(1 + \log xy) dx + \left(1 + \frac{x}{y}\right) dy = 0$. [4]

[f] Evaluate $\int_0^1 \int_0^{\sqrt{1-x^2}} \frac{dx dy}{1+x^2+y^2}$. [4]

Q.2. [a] Solve $xy(1+xy^2)\frac{dy}{dx} = 1$. [6]

[b] Find the area inside the circle $r = a \sin \theta$ and outside the cardioid $r = a(1 + \cos \theta)$. [6]

[c] Apply Runge-kutta Method of fourth order to find an approximate value of y when $x = 0.2$ given that $\frac{dy}{dx} = x + y$ when $y = 1$ at $x = 0$ with step size $h = 0.2$. [8]

Q.3. [a] Show that the length of the curve $9ay^2 = x(x-3a)^2$ is $4\sqrt{3}a$. [6]

[b] Change the order of the integration of $\int_0^1 \int_{-\sqrt{2y-y^2}}^{1+\sqrt{1-y^2}} f(x,y) dx dy$. [6]

[c] Find the volume of the paraboloid $x^2 + y^2 = 4z$ cut off by the plane $z = 4$. [8]

Q.4. [a] Show that $\int_0^1 \frac{x^a - 1}{\log x} dx = \log(a+1)$. [6]

[b] If y satisfies the equation $\frac{dy}{dx} = x^2y - 1$ with $x_0 = 0, y_0 = 1$, using Taylor's Series Method find y at $x=0.1$ (take $h=0.1$). [6]

[c] Find the value of the integral $\int_0^1 \frac{x^2}{1+x^3} dx$ using (i) Trapezoidal rule [8]
(ii) Simpson's 1/3rd rule (iii) Simpson's 3/8th rule.

Q. P. Code: 36997

Q.5.[a] Solve $(y - xy^2)dx - (x + x^2y)dy = 0$. [6]

[b] Evaluate $\iiint \sqrt{1 - \frac{x^2}{a^2} - \frac{y^2}{b^2} - \frac{z^2}{c^2}} dx dy dz$ over the ellipsoid [6]
 $\frac{x^2}{a^2} + \frac{y^2}{b^2} + \frac{z^2}{c^2} = 1$.

[c] Evaluate $(2x + 1)^2 \frac{d^2y}{dx^2} - 2(2x + 1) \frac{dy}{dx} - 12y = 6x$. [8]

Q.6. [a] A resistance of 100 ohms and inductance of 0.5 henries are connected in series with a battery of 20 volts. Find the current at any instant if the relation between L, R, E is $L \frac{di}{dt} + Ri = E$. [6]

[b] Solve by variation parameter method $\frac{d^2y}{dx^2} + 3 \frac{dy}{dx} + 2y = e^{e^x}$. [6]

[c] Evaluate $\iint xy(x - 1)dx dy$ over the region bounded by $xy = 4$, [8]
 $y = 0$, $x = 1$ and $x = 4$.

411

FE - sem-II - Choice Based - A.P-II

21/5/18

Q. P. Code: 24185

[Time: 2 Hours]

[Marks: 60]

- N.B. 1) Question no. 1 is compulsory
2) Solve any 3 questions from question no. 2 to 6.
3) Assume suitable data wherever required.
4) Figures to right indicate full marks.

Q.1. Solve any five from the following. (15M)

- a) Explain how interference in wedge shaped film is used to test optical flatness of given glass plate.
b) What is diffraction grating? What is the advantage of increasing the number of lines in the grating?
c) With neat ray diagram explain the concept of total internal reflection (TIR).
d) Differentiate between spontaneous and stimulated emission.
e) Find cylindrical coordinates of a point $(3\vec{i} + 4\vec{j} + \vec{k})$.
f) In Newton's rings pattern what will be the order of the dark ring which will have double the diameter of the 40th dark ring.
g) Draw the block diagram of cathode ray tube (CRT) and briefly explain functions of its parts.

Q.2

- a) Derive the conditions for maxima and minima due to interference of light reflected from thin film of uniform thickness. (8M)
b) Derive the formula for numerical aperture of step index fibre and give its physical significance. The N.A. of an optical fibre is 0.5 and core refractive index is 1.54. Find the refractive index of cladding. (7M)

Q.3

- a) Discuss the Fraunhofer diffraction at single slit and obtain the condition for minima. In plane transmission grating the angle of diffraction for second order principal maxima for wavelength 5×10^{-5} cm is 35° . Calculate number of lines /cm on diffraction grating. (8M)
b) What is the difference between photography and holography? Explain holography technique to obtain 3-D image of an object. (7M)

Q.4

- a) Find the divergence of vector field $\vec{F} = x^2yz\vec{i} + xz\vec{j}$ (5M)
b) Explain how A.C. voltage and its frequency is measured using CRO. (5M)
c) A wedge shaped air film having an angle of 40 seconds is illuminated by monochromatic light and fringes are observed vertically through a microscope. The distance measured between consecutive bright fringes is 0.12 cm. Calculate wavelength of light used. (5M)

Q. P. Code: 24185

Q.5

- a) Explain Newton's rings experiment and show that diameters of n^{th} dark rings are proportional to square root of natural numbers. (5M)
- b) Write Maxwell's equations and give its physical significance. (5M)
- c) Explain construction and working of atomic force microscope. (5M)

Q.6

- a) Explain different types of carbon nanotubes and give its applications. (5M)
 - b) Explain construction and working of Nd:YAG laser. (5M)
 - c) Write a note on electrostatic focussing. (5M)
-

379

FE - Sem - II - choice Based - A.C - II

25/5/12

Q.P. Code :013176

[Time: 02 Hours]

[Marks:60]

Please check whether you have got the right question paper.

- N.B:
- 1) Questions no.1 is compulsory.
 - 2) Attempt any three questions from remaining five questions.
 - 3) Figures to the right indicate full marks.
 - 4) Atomic alt:-Al=27, Ca=40, S=32, Cl=35.5, Fe=56, K=39, C=12, N=14, O=16, Na=23, Mg=24.

Q.1 Attempt any five of the following

15

- (a) Define power alcohol. Give any two advantages of power alcohol.
- (b) Explain why cathodic coating is preferred over anodic coating for manufacturing of containers to store food stuffs.
- (c) A sample of coal has the following composition:-
C = 70%, O = 23%, H = 5%, S = 1.5%, N = 0.4%, Ash = 0.1%,
calculate the G.C.V. of this fuel.
- (d) Give the composition, properties and uses of high phosphorus bronze.
- (e) Why is it essential to design safer chemicals and products w.r.t. green chemistry principle? Explain with an example.
- (f) What is the matrix phase and particle phase in concrete? Give any two properties of concrete.
- (g) Porous film is also called as 'Non protective film'. Explain with an example.

Q.2 (a) Define electrochemical corrosion. Explain Intergranular corrosion with a neat labelled diagram. 06

(b) i) 1.95 gm of a coal sample was taken for nitrogen estimation by Kjeldahis's method. The ammonia liberated required 9.5ml of 0.4 N H₂SO₄ for neutralisation. Calculate the percentage of Nitrogen in coal sample. 03

ii) Write a note on Green solvents 02

(c) Explain the structural composition of plywood. 04

Q.3 (a) Define fuel cell. Explain Hydrogen Oxygen fuel cell with a neat labelled diagram. 06

(b) i) Define shape memory Alloy. Give its properties and uses. (Any two) 03

ii) Define Bio-Diesel and give its advantages. 02

(c) Calculate the % atom economy of the following reaction w.r.t. the product acetophenone. 04



TURN OVER

Q.P. Code :013176

- Q.4 (a) What is cathodic protection? Explain impressed current cathodic protection with its applications. 06
(b) i) What is Green chemistry? Give its significance. 03
ii) Define composite. Give any two applications of composite material 02
(c) What is powder metallurgy? Explain hot compaction method with a neat labeled diagram. 04
- Q.5 (a) A gaseous fuel contains $H_2 = 50\%$, $CH_4 = 30\%$, $N_2 = 2\%$, $CO = 7\%$, $C_2H_4 = 3\%$, $C_2H_6 = 5\%$, and watervapour=3%, Calculate weight and volume of air required for $2m^3$ of the gas. [Given: Mol. Wt. of an air =28.949kg] 06
(b) i) List the three main constituents of paint and give functions of each. 03
ii) Explain the effect of the following alloying elements on steel. 02
a) Chromium b)Tungsten
(c) Explain conventional and Green chemistry route for production of Ibuprofen Highlight the green chemistry principle involved. 04
- Q.6 (a) Write short notes on:- 06
a)Computing b) Sintering
(b) i) What are Fiber Reinforced composite 03
ii) Explain how areas of anode and cathode effect the rate of corrosion 02
(c) Explain the determination of % moisture and % volatile matter in a coal sample. 04

QP CODE : 21664

(3 Hours)

[Total Marks:60

- i) Solve any **FOUR** questions.
- ii) All dimensions are in mm.
- iii) Use first angle method of projection.
- iv) Assume suitable dimension if it is necessary.
- v) Retain all construction lines.

- Q.1 Following figure shows the pictorial view of an object, draw
- i) Sectional front view along section P-Q
 - ii) Top view
 - iii) Right Hand Side view

[5]
[4]
[4]

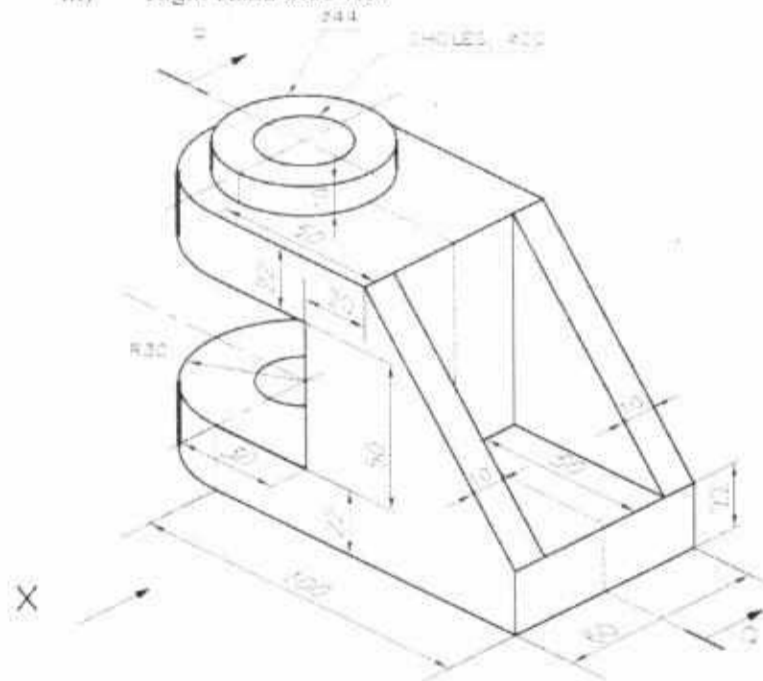

- iv) Insert 10 major dimensions

[2]

- Q.2 A pentagonal pyramid side of base 35mm and height 70mm is having one of its base edge in HP with triangular surface containing this edge perpendicular to HP, parallel to VP and away from observer. Draw its projections.

[15]

[TURN OVER

QP CODE : 21664

Q.3 (a) Front view and side view of an object is shown in figure, draw an Isometric View. [8]

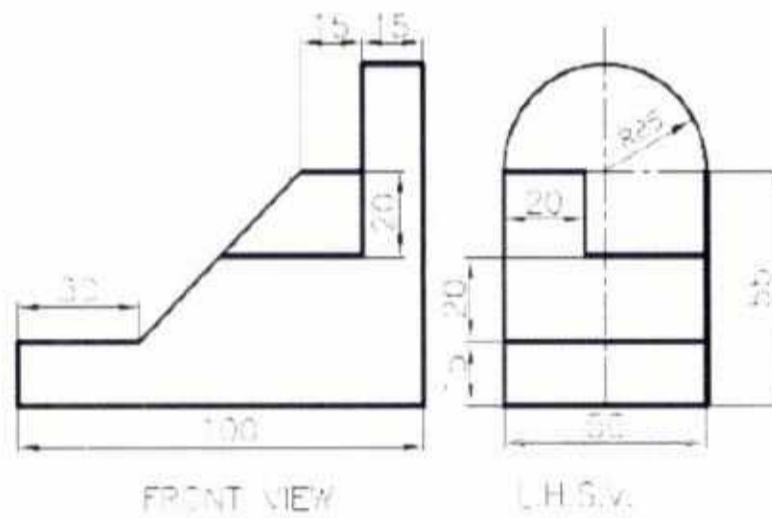

(b) Draw the elevation and plan of a cube of side 50mm resting on one of its corner of base on HP with solid diagonal perpendicular to the VP. [7]

Q.4 (a) The pictorial view of a machine part is shown in following figure. Draw
 i) Front view from X [4]
 ii) Top view [4]
 iii) Insert at least 6 Dimensions. [1]

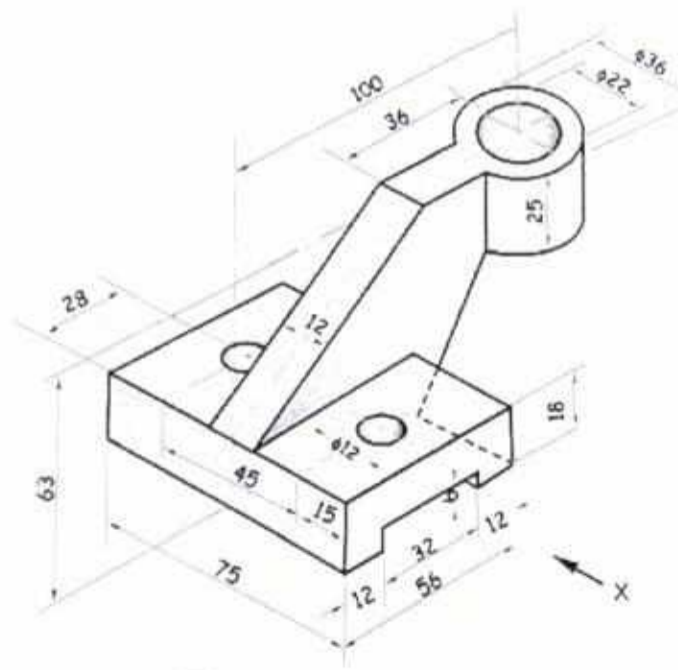

(b) Draw 1.5 revolution of a cylindrical helix of pitch 60mm on a cylinder of 50mm diameter. [6]

[TURN OVER

QP CODE : 21664

- Q.5 A right circular cone having diameter of base 60mm, axis length 80mm resting on its base on HP is cut by cutting plane perpendicular to VP and inclined to HP at 60° , bisects the axis. Draw its FV, sectional TV and the true shape of section. Also draw the development of lateral surface of the cone after removing the portion containing the apex. [15]
- Q6 (a) End A of line AB is in second quadrant and is 40mm and 15mm from HP and VP respectively. The line is inclined at 40° to both the reference planes. Draw its projection when end B is in third quadrant and 45mm from HP. Find true length and distance of end B from VP. [8]
- (b) Front view and sideview of an object are shown in figure, draw an isometric view. [7]

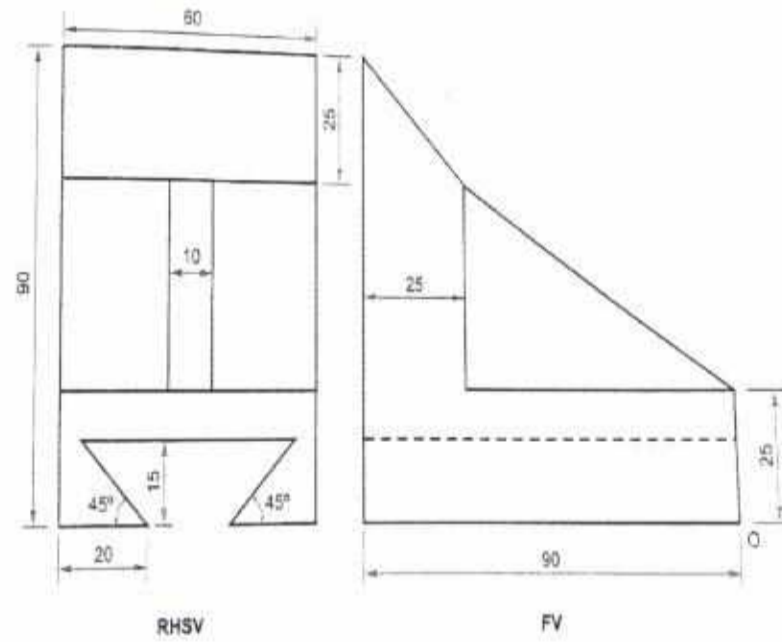

408

FE-sem-II- choice Based - SPA

31/5/18

Q. P. Code: 40231

N.B

- (1) Question no. 1 is compulsory.
- (2) Attempt any 3 from the remaining questions.
- (3) Assume suitable data if necessary.
- (4) Figures to right indicate full marks.

(3 Hours)

[Max. Marks 80]

- Q.1 (a) Select the correct option from multiple choice questions. 10
- i. Which bitwise operator is used to multiply the number by 2^n where n is number of bits.
A] Bitwise-OR B] Bitwise-AND C] Bitwise Left shift D] Bitwise Right Shift
 - ii. Which operator has the lowest priority?
A] ++ B] % C] + D] ||
 - iii. Which of these is a valid variable declaration?
A] int emp salary; B] float marks_student; C] float roll-no; D] int main;
 - iv. What will be the output of the following program?

```
void main ( ) {  
double x=28;  
int r;  
r= x%5;  
printf ("\n r=%d", r);  
}
```

A] r= 3 B] Run time Error C]Compile time Error D]None of the Above
 - v. What will be the output of the following program?

```
void main( ) {  
int x []= {10,20,30,40,50};  
printf ("\n %d %d %d %d", x [4],3[x],x[2],1[x],x[0] );  
}
```

A]Error B]10 20 30 40 50 C]50 40 30 20 10 D]None of these
 - vi. Which of the following is not a keyword of 'C' ?
A]auto B]register C]int D]function
 - vii. What will be the output ?

```
void main ( ) {  
int y;  
y=0x10+ 010+10;  
printf ("\ny=%x", y);  
}
```

A] y = 34 B] x = 34 C] y = 22 D]Error

Q. P. Code: 40231

Study the following C program

viii.

```
void main ( ) {  
    int a= 0;  
    for ( ; a );  
    a++; }  
what will be the value of the variable a, on the execution of the above program  
A] 1 B] 0 C] -1 D] none of these
```

Which of the following is used as a string termination character?

ix. A] 0 B] \0 C] /0 D] None of these

What will be the output of the following program code?

x.

```
void main ( ) {  
    char a[] = "Hello World";  
    char *p;  
    p=a;  
    printf("\n%d %d %d %d", sizeof(a), sizeof(p), strlen(a), strlen(p)); }  
A] 11 11 10 10 B] 10 10 10 10 C] 12 12 11 11 D] 12 2 11 11
```

- Q.1 b State True or False with reason. 10
- Size of pointer variable is equal to the datatype it points to.
 - A float constant cannot be used as a case constant in a switch statement.
 - The statement `void p;` is valid.
 - `while (0);` is an infinite loop.
 - `scanf()` function is used to input string having multiple words
 - A function can have any number of return statements.
 - In a union, space is allocated to every member individually.
 - An algorithm is a graphical representation of the logic of a program.
 - Comments in the program make debugging of the program easier.
 - There is no difference between `'\0'` and `'0'`.

- Q.2 a. i. How to create array of structure variables and assign values to its members? 5
ii. Differentiate between struct and union. When is union preferred over struct? 5
Give one example of each.

- Q.2 b. i. WAP to print the sum of the following series: 5
 $1 + 2^2 + 3^3 + \dots + n^n$
ii. Compare the following: 5
i) break and continue statements
ii) if-else and switch statements

- Q.3 a. Write a program to calculate number of vowels (a, e, i, o, u) separately in the 6
entered string.

- b. Predict output of following program segment. 4
[Note: Show pictorial representation]

Q. P. Code: 40231

```
(i)main()
{
    int a,b,*p1,*p2,x,y;
    a=48;b=10;p1=&a;p2=&b;
    x=*p1**p2-8;
    *p1=*p1*p2;
    y>(*p1/*p2)+20;
    printf("%d %d %d %d %d %d", *p1,*p2,a,b,x,y);
}
```

```
(ii)
main()
{
    int x=4,y=9,z;
    z = x++ + --y +y;
    printf("\n %d %d %d",x,y,z);
    z = --x + x + y--;
    printf("\n %d %d %d",x,y,z);
}
```

- c. An electronic component vendor supplies three products: transistors, resistors and capacitors. The vendor gives a discount of 10% on order for transistors if the order is more than Rs. 1000. On order of more than Rs. 100 for resistors, a discount of 5% is given and discount of 10% is given on orders for capacitors of value more than Rs. 500. Assume numeric code 1, 2 and 3 used for transistors, capacitors and resistors respectively. Write a program that reads the product code and the order amount, and prints out the net amount that the customer is required to pay after discount. (Note: Use switch-case) 10

Q.4 a. What is recursion? WAP using recursion to find sum of array elements of size n. 10

Q.4 b. Write a C program to 10

- i. Create a 2D array (Matrix) [in main function]
- ii. Write a function to read 2D array(Matrix)
- iii. Write a function that will return true(1) if entered matrix is symmetric or false(0) is not symmetric.
- iv. Print whether entered matrix is symmetric or not [in main function]

Q.5 a. Implements string copy function STRCOPY (str1, str2) that copies a string str1 (source) to another string str2 (destination) without using library function. 05

b. Explain File handling in c in detail. [Note: Mention file types, file modes, file related functions and its use] 08

Q. P. Code: 40231

- c. WAP to print all possible combinations of 1, 2, 3 using nested loops. 07
- Q.6 a. WAP to print following pattern for n lines. [Note: range of n is 1-9] 05
- ```
1
121
12321
1234321
```
- b. WAP to print binary equivalent of entered decimal no. 05
- c. What is significance of storage classes? Explain it with relevant examples. 10

\*\*\*\*\*

367

FE - sem - II - Choice Based - C.S

6/6/11

Q.P.Code: 24736

(2 Hours)

Total marks: 40

N. B. (1) Question No 1 is compulsory

(2) Attempt any three out of Five questions

1. (a) List 2 situations which could occur in your personal life where you would choose to speak rather than write. Explain the reasons for your choice. (3)  
(b) Give the diagrammatic representation of Complete Block Form (2)  
(c) Explain the relevance of diagrams while describing an object (2)  
(d) Techniques to improve listening skills (3)
2. (a) Explain Proxemics (3)  
(b) Write short notes on completeness (2)  
(c) When is **Note** given in instructions? (2)  
(d) Find one word substitutes for the following phrases: (3)  
(i) An instrument for measuring earthquakes S-----  
(ii) To move from one country to another M-----  
(iii) Murder of a new born child I-----
3. (a). How is courtesy shown in business letters? Give at least two examples. (2)  
(b). Meera Biscuits Mart, Lonavala have complained that they received a consignment of 100 kg of biscuits in a broken condition and have asked for adjustment. They have attributed the damage to defective packaging. On behalf of Shandesh Biscuits and Food Products, Mumbai write a suitable reply. (6)  
(c). What is the importance of Feedback In Communication process? (2)
4. (a). Distinguish between oral and written communication. (2)  
(b). Give the difference in meaning for each of the following pairs of words: (2)  
(i) Various , varied  
(ii) Climate , weather  
(c) Your company is organizing a two day conference in New Delhi and you expect Sales Personnel from branches all over India to attend. As the Convener of the conference write to a hotel enquiring about facilities like conference hall, food and accommodation the participants. Give necessary details. (6)
5. (a). Write short notes on: (4)  
(i). Chronemics  
(ii). 'Precaution' in Instructions  
(b). Describe **Any One** of the following objects: (4)  
(i). Head Phones  
(ii). Scanner

Turn Over

(c). Give the diagrammatic representation of Communication Cycle. (2)

6. (a) Read the following passage and answer the questions given below:

But man is not destined to vanish. He can be killed, but he cannot be destroyed, because his soul is deathless and his spirit is irrepressible. Therefore, though the situation seems dark in the context of the confrontation between the superpowers, the silver lining is provided by amazing phenomenon that the very nations which have spent incalculable resources and energy for the production of deadly weapons are desperately trying to find out how they might never be used. They threaten each other, intimidate each other and go to the brink, but before the total hour arrives they withdraw from the brink.

- i. **The main point from the author's view is that** (01)
- Man's soul and spirit cannot be destroyed by superpowers.
  - Man's destiny is not fully clear or visible.
  - Man's soul and spirit are immortal.
  - Man's safety is assured by the delicate balance of power in terms of nuclear weapons.
  - Human society will survive despite the serious threat of total annihilation.
- ii. **The phrase 'Go to the brink' in the passage means** (01)
- Retreating from extreme danger.
  - Declare war on each other.
  - Advancing to the stage of war but not engaging in it.
  - Negotiate for peace.
  - Commit suicide.
- iii. **In the author's opinion** (01)
- Huge stockpiles of destructive weapons have so far saved mankind from a catastrophe.
  - Superpowers have at last realized the need for abandoning the production of lethal weapons.
  - Mankind is heading towards complete destruction.
  - Nations in possession of huge stockpiles of lethal weapons are trying hard to avoid actual conflict.
  - There is a Silver lining over the production of deadly weapons.
- iv. **'Irrepressible' in the second line means** (01)
- incompatible
  - strong
  - oppressive
  - unrestrainable
  - unspirited
- v. **A suitable title for the above passage is** (01)
- Destruction of mankind is inevitable.
  - Man's desire to survive inhibits use of deadly weapons.
  - Mounting cost of modern weapons.
  - Threats and intimidation between super powers.
  - Cowardly retreat by man

6. (b). List any **Ten** Instructions to follow while welding an object. (05)