

A PROJECT REPORT

ON

**“DESIGN A CONTROL SYSTEM FOR MUSCULAR DYSTROPHY
PATIENT”**

Submitted by

KHAN JAWWAD (14ME20)

GUPTA AMIT (14ME14)

KHAN MEHSHAR (13ME26)

PATEL OVAIS (14ME41)

In partial fulfillment for the award of the Degree

Of

BACHELOR OF ENGINEERING

IN

MECHANICAL ENGINEERING

UNDER THE GUIDANCE

Of

Prof. ZIA MOMIN

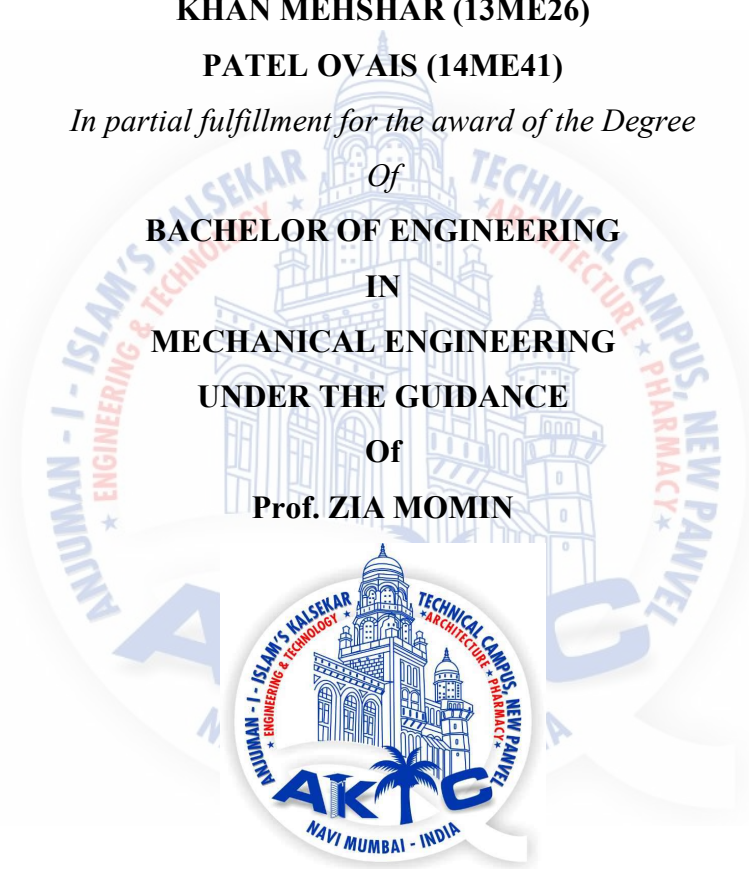

DEPARTMENT OF MECHANICAL ENGINEERING

ANJUMAN-I-ISLAM

KALSEKAR TECHNICAL CAMPUS NEW PANVEL,

NAVI MUMBAI – 410206

UNIVERSITY OF MUMBAI

ACADEMIC YEAR 2017-2018



ANJUMAN-I-ISLAM
KALSEKAR TECHNICAL CAMPUS NEW PANVEL
(Approved by AICTE, recg. By Maharashtra Govt. DTE,
Affiliated to Mumbai University)

PLOT #2&3, SECTOR 16, NEAR THANA NAKA, KHANDAGAON, NEW PANVEL, NAVI MUMBAI-410206, Tel.: +91 22 27481247/48 * Website: www.aiktc.org

CERTIFICATE

This is to certify that the project entitled
“DESIGN A CONTROL SYSTEM FOR MUSCULAR DYSTROPHY PATIENT”

Submitted by
KHAN JAWWAD
GUPTA AMIT
KHAN MEHSHAR
PATEL OVAIS

To the Kalsekar Technical Campus, New Panvel is a record of bonafide work carried out by him under our supervision and guidance, for partial fulfilment of the requirements for the award of the Degree of Bachelor of Engineering in Mechanical Engineering as prescribed by **University Of Mumbai**, is approved.

Internal Examiner

(Prof. _____)

External Examiner

(Prof. _____)

Head of Department

(Prof. _____)

Principal

(Dr. _____)



ANJUMAN-I-ISLAM
KALSEKAR TECHNICAL CAMPUS NEW PANVEL
(Approved by AICTE, reg. By Maharashtra Govt. DTE,
Affiliated to Mumbai University)

PLOT #2&3, SECTOR 16, NEAR THANA NAKA, KHANDAGAON, NEW PANVEL, NAVI MUMBAI-410206, Tel.: +91 22 27481247/48 * Website: www.aiktc.org

APPROVAL OF DISSERTATION

This is to certify that the thesis entitled
“DESIGN A CONTROL SYSTEM FOR MUSCULAR DYSTROPHY PATIENT”

Submitted by

KHAN JAWWAD

GUPTA AMIT

KHAN MEHSHAR

PATEL OVAIS

In partial fulfilment of the requirements for the award of the Degree of Bachelor of Engineering in Mechanical Engineering, as prescribed by University of Mumbai approved.

(Internal Examiner)

(External Examiner)

Date: _____

ACKNOWLEDGEMENT

After the completion of this work, we would like to give our sincere thanks to all those who helped us to reach our goal. It's a great pleasure and moment of immense satisfaction for us to express my profound gratitude to our guide **Prof. ZIA MOMIN** whose constant encouragement enabled us to work enthusiastically. His perpetual motivation, patience and excellent expertise in discussion during progress of the project work have benefited us to an extent, which is beyond expression.

We would also like to give our sincere thanks to **Prof. ZAKIR ANSARI** Head of Department, **Prof. YUSUF KHAN**, Project Co-Guide and Prof. ZIA MOMIN, Project coordinator from Department of Mechanical Engineering, Kalsekar Technical Campus, New Panvel, for their guidance, encouragement and support during a project.

I take this opportunity to give sincere thanks to **Mr. MILIND GAWAND** for sponsor us.

I am thankful to **Dr. ABDUL RAZZAK**, director of Kalsekar Technical Campus New Panvel, for providing an outstanding academic environment, also for providing the adequate facilities.

Last but not the least I would also like to thank all the staffs of Kalsekar Technical Campus (Mechanical Engineering Department) for their valuable guidance with their interest and valuable suggestions brightened us.

KHAN JAWWAD

GUPTA AMIT

KHAN MEHSHAR

PATEL OVAIS

Abstract

According to census made in 2011 there were approximately 54 lakh patient suffering from movement disability. Our aim is to design & fabricate 3wheeler dual controlled system vehicle which will be driven by both escort as well as the handicap person. This vehicle will help to increase the travelling range of handicap persons by increasing their mobility. The side-car was designed on Solidworks & after all sorts of analysis positive results were shown. The side-car will be coupled to the aprilia sr150. The handicap person travelling on wheelchair will be entering into the side-car with the help of motorized ramp. This vehicle will be driven by handicap person using joystick which will be controlling basic things like steering, acceleration & brakes. For safety of the handicap person we will be using special E-Z lock & seat belt arrangements. In case of emergency separate kill switch arrangement will be given. Our project will change the travelling sense of handicap people to live a better & normal life & help them travel across the society.

KEYWORDS: Side-car, Joystick, Motorized-ramp, E-Z lock

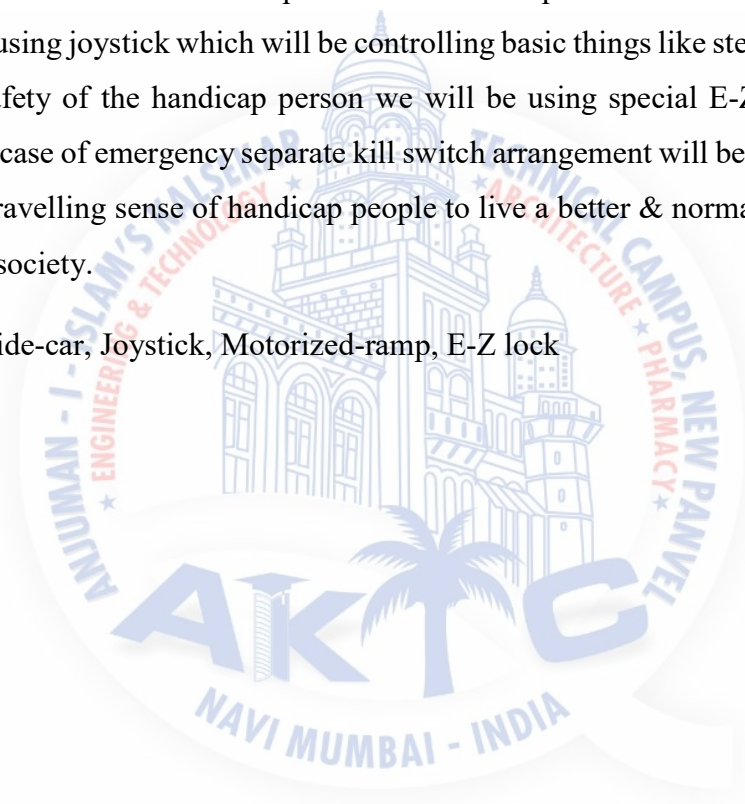

Table of Contents

Title page.....	i
Certificate.....	ii
Approval of dissertation.....	iii
Acknowledgement	iv
Abstract.....	1
Table of content.....	2
List of figure.....	4
List of table.....	6
1. Introduction.....	7
1.1 Introduction.....	8
2. Literature survey.....	10
2.1 Literature review.....	11
3. Methodology.....	15
3.1 Methodology.....	16
4. Selection of scooter.....	17
4.1 Selection of vehicle:.....	18
CALCULATION:.....	18
5. Project overview.....	21
5.1 Design objective.....	22
5.1.1 Chassis design.....	22
5.1.2 Chassis prototype.....	24
5.2 Profile cutting.....	27
6. Material selection.....	28

7. Structure analysis	33
7.1 Introduction	34
7.1.1 Material Selection.....	35
7.1.2 Material properties	36
7.1.2 Meshing.....	37
7.1.3 Supports and Forces	38
7.1.4 Solution information.....	41
8. Fabrication.....	45
8.1 Material Cutting	46
8.2 Fitting and Welding	47
8.3 Final part	48
9. Suspension system	49
9.1 Suspension system	50
10. Control system	51
10.1 Basic control required:	52
10.1.1 Braking system	53
10.1.2 Acceleration control:	54
10.1.3 Steering Control:	55
10.2 Ramp system	55
10.3 Thing to be installed in the control system	57
11. Cost report	61
11.1 Cost report:	62
12. Future scope	63
12.1 Future scope:	64
13. Conclusion.....	67
14. References.....	71

List of figures

Figure 1.1 Milind Gawand (handicapped person)	8
Figure 2.1 Free Body Diagram of a Vehicle moving up an inclined surface	11
Figure 2.2 cad design for three wheeler vehicle	12
Figure 2.3 Front view of tricycle for disabled person.....	13
Figure 2.4 steering wheel in the prototype of eco-car	14
Figure 4.1 Aprilia SR150.....	20
Figure 5.1 Model of side car in solid works	23
Figure 5.2 Chassis model on solid works	24
Figure 5.3 Prototype of chassis.....	25
Figure 5.4 Profile of flange.....	27
Figure 6.1 Material for flange (stainless steel)	31
Figure 6.2 Aluminium sheet	32
Figure 7.1 Model on solid woks	35
Figure 7.2 Chassis model with meshing.....	37
Figure 7.3 model with fixed support (static test)	39
Figure 7.4 model with fixed support (static test).....	39
Figure 7.5 Forces applied on model.....	40
Figure 7.6 FRONT IMPACT-Stress-Stress1	41
Figure 7.7 FRONT IMPACT-Displacement-Displacement1	42
Figure 7.8 REAR IMPACT-Stress-Stress1.....	43
Figure 7.9 REAR IMPACT-Displacement-Displacement1	43

Figure 7.10 Copy-Static 1-Stress-Stress1	44
Figure 7.11 Copy-Static 1-Displacement-Displacement1	44
Figure 8.1 Material Cutting.....	46
Figure 8.2 Welding during fabrication.....	47
Figure 8.3 Assembly of vehicle	48
Figure 9.1 suspension (Aprilia SR150).....	50
Figure 10.1 controlling of automatic side mirror in car.....	52
Figure 10.2 dual brake in activa 4G.....	53
Figure 10.3 Brake.....	53
Figure 10.4 Acceleration.....	54
Figure 10.5 mounting of motor for controlling of steering.....	55
Figure 10.6 linear actuator	55
Figure 10.7 Ramp in side car	56
Figure 10.8 Battery level indicator (12v).....	57
Figure 10.9 left right indicator switch.....	58
Figure 10.10 horn (button).....	58
Figure 10.11 push button	59
Figure 10.12 ignition switch	59
Figure 10.13 kill switch	60
Figure 14.1 front side of the vehicle	69
Figure 14.2 back side of the vehicle	70

List of tables

Table 6.1 Material properties (AISI 1018)	29
Table 6.2 Material properties (AISI 4130)	30
Table 6.3 Material properties (stainless steel)	31
Table 7.1 material properties in solid work	36
Table 7.2 meshing information	38
Table 7.3 load details	41
Table 7.4 stress result (front impact test).....	41
Table 7.5 displacement result (front impact test).....	42
Table 7.6 stress result (rear impact test)	43
Table 7.7 displacement result (rear impact test)	43
Table 7.8 stress result (static impact test)	44
Table 7.9 displacement result (static impact test).....	44
Table 13.1 cost report	62

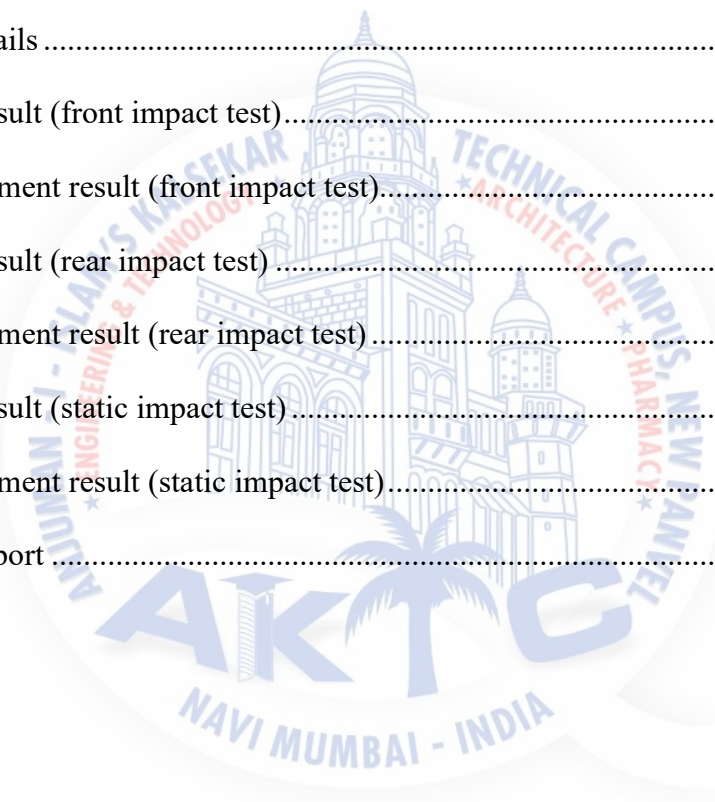

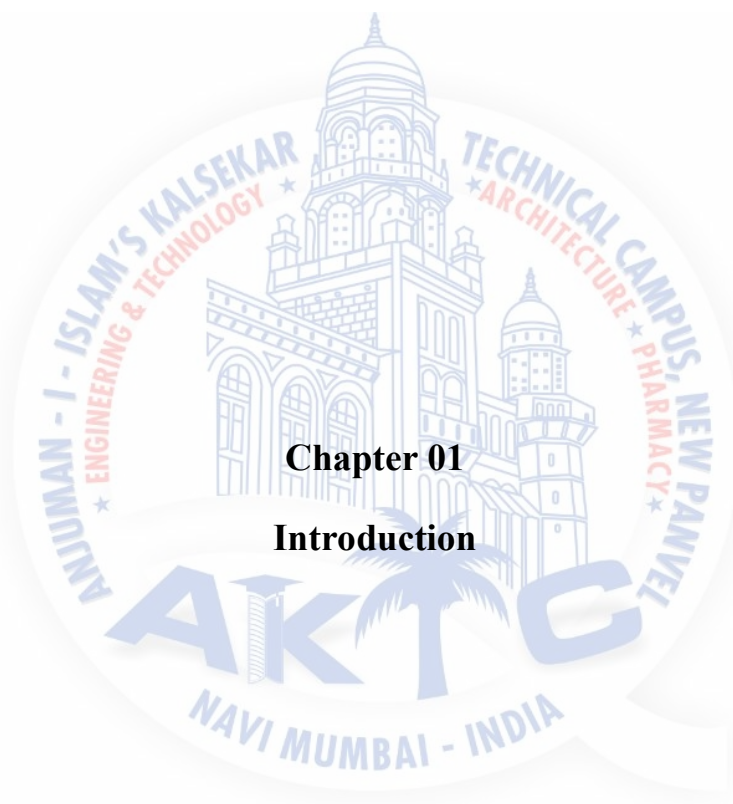

Chapter 01

Introduction

1.1 Introduction

Mr Milind sir contacted us after watching the video on YouTube, a car made by our seniors for the handicap person under the guidance of our Prof.. Zia Momin. He wanted us to make a car for himself so that he can independently drive from one place to another. Unfortunately, he has a disease known as muscular dystrophy that is he loses his muscle power from time to time. His hands movement is also limited to a very close distance from his chest. He almost lost all his leg power so he uses an electric wheelchair to move around. All these reasons made him choose to contact us to make a car for him. Seeing his will to move independently all by himself, his motivation and always smiling face made us wonder how weak we actually are.

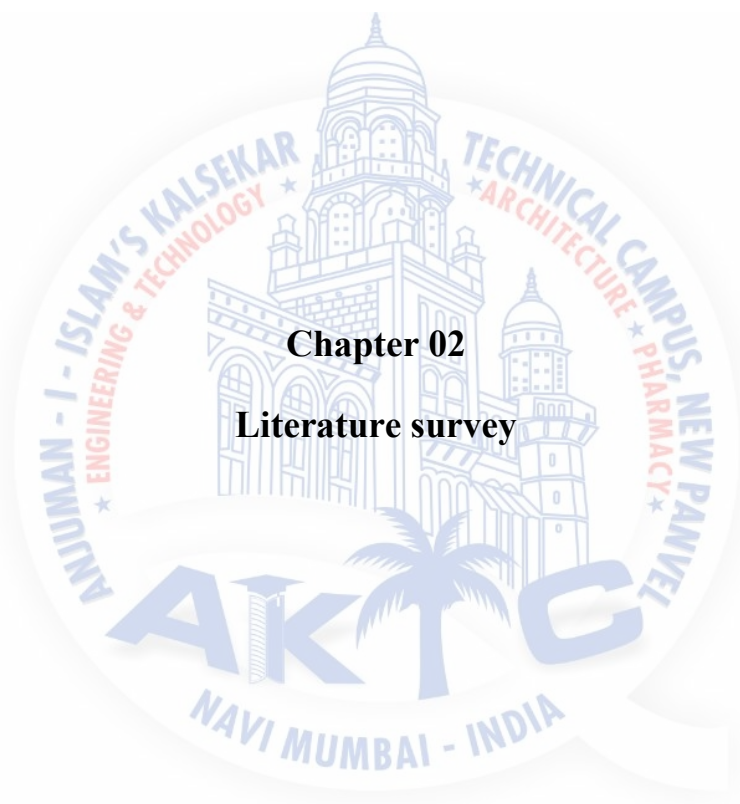

Figure 1.1. Milind Gawand (handicapped person)

He requested us to make him a car such that he and an escort can drive it, that means a dual control system car, one for the handicap person and one for the normal person. This dual control system part was a big challenge for us because a normal car for him with an electronic remote control for steering acceleration and brake can be easily made but the challenge here was to make a dual control system at same time in the same vehicle. He asked us to make him this kind of car because his muscle can lose his strength that is he may get tired. A person driving with such a disease is risky so we were not sure if we should proceed with this idea, but he made us sure and promised us that 80 percent of the time there will be someone or the other from his family with him to drive him around, that is the reason for a dual control system car.

Our team of 8 members previously decided to fabricate the whole car but after research and survey and the time period, we found many complications like building the whole car will require custom hubs for tyres, custom hubs will require custom driving shaft means axels, custom axle will require custom steering mechanism and most importantly we couldn't find an engine with automatic transmission which comes in our budget and take the load of his wheelchair so you can see all this will complicate our project as well as increase the cost and consume a lot of time.

That is why our team members and Zia sir concluded to fabricate a side car for the handicap person. This side car will be attached to Aprilia SR150 our decided vehicle because of its 11.4 BHP and automatic transmission. Aprilia was decided because it can take the load of his wheel chair which was more that 200kg including him. Deciding to make side car instead of the whole car will minimise some of work.



Chapter 02
Literature survey

2.1 Literature review

A chassis consists of an internal framework that supports a man-made object in its construction and use. It is analogous to an animal's skeleton. An example of a chassis is the under part of a motor vehicle, consisting of the frame (on which the body is mounted).

The chassis takes a load of the operator, Engine, brake system, and steering mechanism, so chassis should have adequate strength to protect the operator in the event of an impact. The driver cabin must have the capacity to resist all the forces exerted upon it. This can be achieved either by using high strength material or better cross section against the applied load.

Saurabh Chauhan et al [1] Electric vehicles save fuel cost, cause less pollution and bring lucrative tax cuts. They are a much safer ride as they can't travel too fast and have less tyre wear. All electric vehicles have one thing in common and that is that all of them use Direct current electric motors to drive the wheels. However, these motors are available with a number of variations in speed, size and method of operation, the torque required from the vehicle to obtain desirable characteristics is the same. It is the torque that forms the part of the force to drive the wheels and set the vehicle in motion. In simple terms the torque may be defined as the turning power of the motor. The following paper presents one such method of calculating the torque.

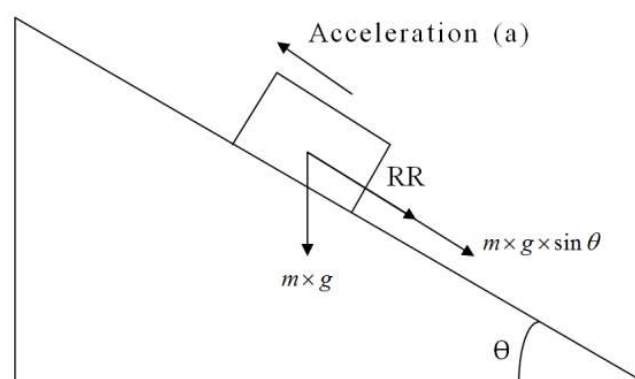

Figure 2.1 Free Body Diagram of a Vehicle moving up an inclined surface

B sathish Kumar et al [2] In today's world, transportation has become one of the prime requirements of people for moving self or goods from one place to another. We have even come across people travelling for more than 200 km every day for reaching their work place. Mobility has thus become an essential part of our lives with many development and improvements happening in this field. Because of the changing lifestyle of today's world, there is a huge reduction in the level of interactions within the people group. In these conditions it becomes more difficult for physically challenged people to commute and to perform their day to day activities like working, education, shopping etc. as they have to constantly depend on others for getting assistance to alight and board the vehicle. In this project. a feasible design solution in form of a user friendly three-wheeler vehicle, which allows physically challenged people to commute on their own and perform their activities without anyone's assistance, has been proposed.

The activity was started with customer survey and market study. The questionnaire was framed keeping the needs of physically challenged people in mind. The major inputs received from this study were related to ingress/egress issues, ergonomics, carrying wheel chair and utility space. Considering these inputs from the survey, two concepts, namely – Chariot and Sholay, were generated. Using Pugh matrix Sholay concept was finalised for carrying out the detail design. Layout and detail design was carried using CATIA. The finalised model was analysed to validate for stiffness and Ergonomics. Ergonomics study using Jack software was carried out considering the 5th and 95th percentile manikins to take care of the ergonomic issues. On finalising the design, prototype building activity was initiated. A full scale working prototype model was manufactured for physical validation of the design function.

Outcome of this project is the solution of transport for physically challenged community using which they can commute and lead an independent and normal life.



Figure 2.2.cad design for three wheeler vehicle

Ajit A. Mohekar et al [3] mobility of physically disabled person is a concerning social issue nowadays. Various hand driven tricycles, wheelchair, retrofitted vehicles etc. are commonly available for disabled people as a mode of transportation existing means of transportation for disabled person to dismount from the wheelchair. A retrofitted tricycle is designed to overcome this problem by allowing the disabled person to wheel up or down his wheelchair onto or down the tricycle. This is achieved using a specially designed platform that allows the wheelchair to be wheeled up or down. This paper discusses an attempt to design and fabricate a retrofitted tricycle for disabled people. This tricycle is specifically designed to suit wheelchair occupants.

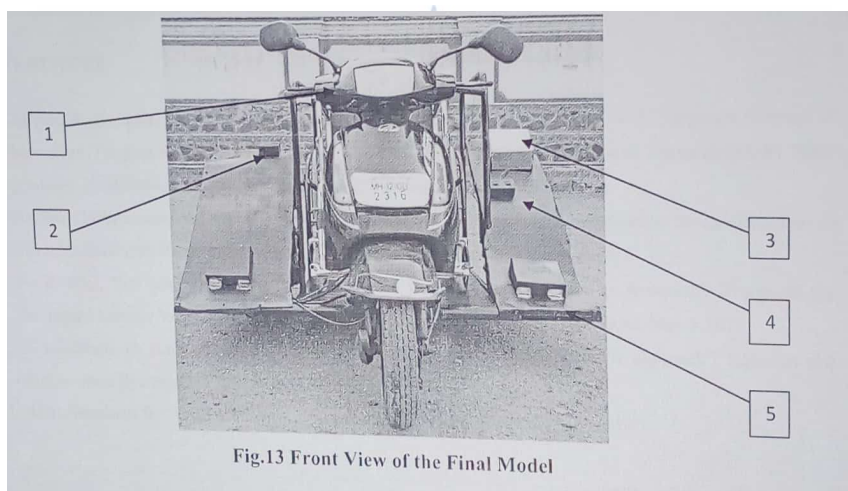

Figure 2.3. Front view of tricycle for disabled person

Włodzimierz Choromanski et al [4] individual adjustment of the controls, that are part of the driver interface, for people with different levels of disability requires a specific design approach. Individualization in this respect may result in a larger group of people being able to control the car. The subject of the analysis is a multifunction steering wheel designed for people with paresis of the lower motor system. It is designed to let the driver steer the car and platform the key control functions with use of the upper limbs only. The designers did their best to make sure that driving the car is as intuitive as possible. The design of the steering wheel is heavily parameterized, i.e. a number of its parameter can be adjusted. Among them is the ratio between the turning angle of the steering wheel and the angle of the front wheels. This features has been subject to examination in dynamic simulators and simulation studies during special test.



Figure 2.4. steering wheel in the prototype of eco-car

NAVI MUMBAI - INDIA

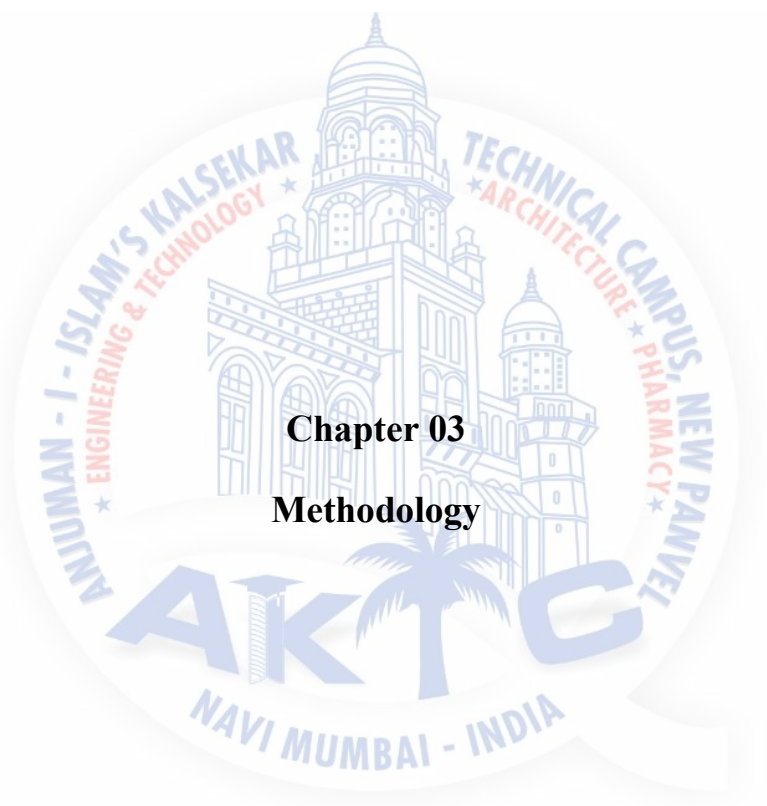

Chapter 03

Methodology

3.1 Methodology

STEP1: Division of Team

1. Design Team
2. Control Team

STEP2: Power Calculation of vehicle.

STEP3: Selection of vehicle.

STEP4 Measurement of hand power of Handicap Person.

STEP5: Measurement & Calculation of Forces & Torque required for steering, brake & acceleration.

STEP6: Selection of Control System and Motor.

STEP7: Selection of Motor for Ramp.

STEP8: Development of Electro-Mechanical Mechanism.

STEP9: Fabrication

STEP10: Testing.

STEP11: Remodelling.

STEP12: Final testing.

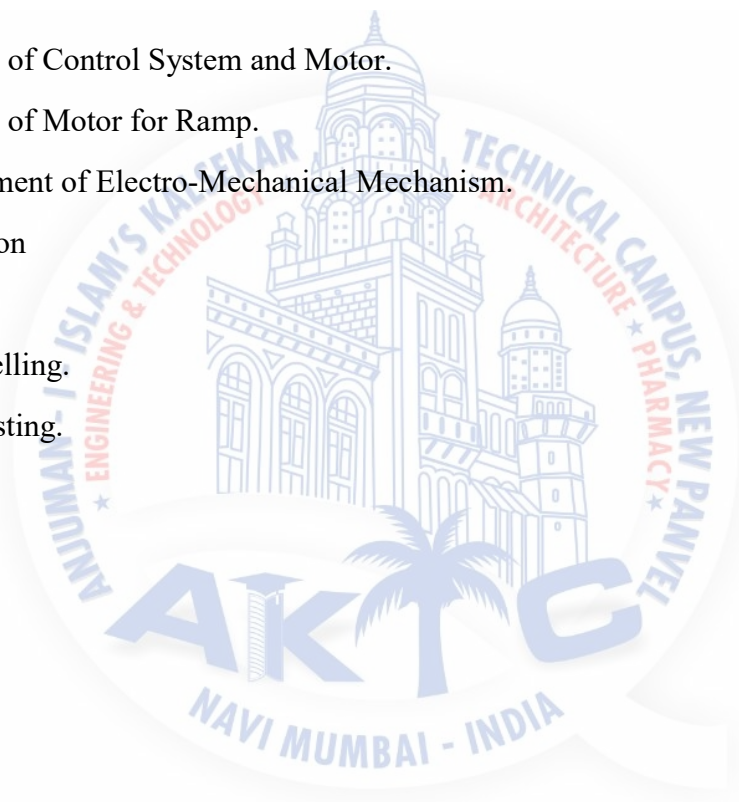

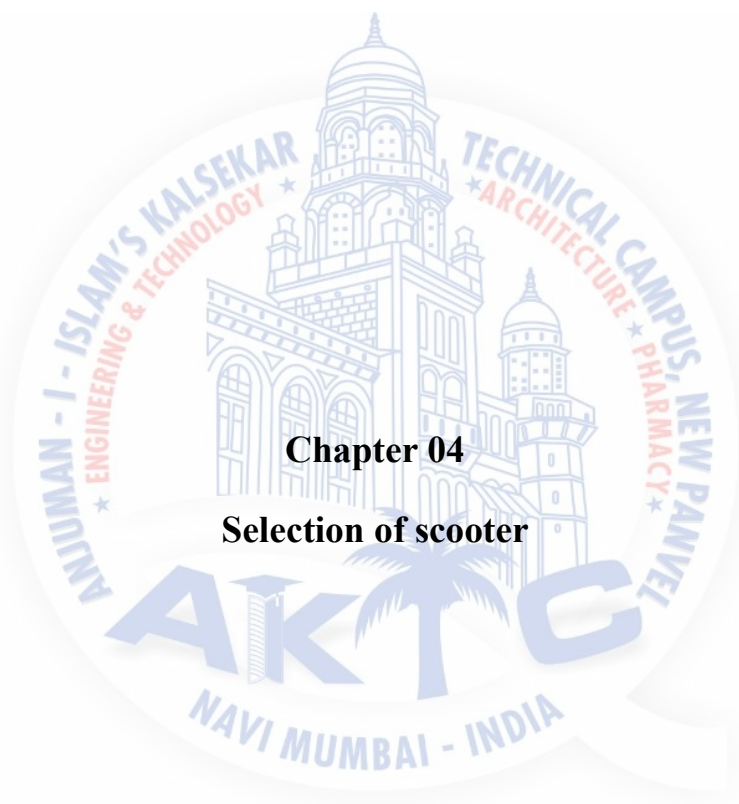

Chapter 04

Selection of scooter

4.1 Selection of vehicle:

The vehicle selection is based on the total weight the vehicle will going to carry including the weight of both driver, the patient, wheelchair and also side car weight. So indirectly it is based on the vehicle powers. We have done the calculation which is as follows

CALCULATION:

Total load (m) = 500 kg

$$\mathbf{F(t) = F(r) + F(p) + F(tr)}$$

F(t) → Total Force

F(r) → Rolling Resistance Force

F(p) → Pulling Force on inclined plane

F(tr) → Traction Force

$$\mathbf{F(r) = c \times mg}$$

c → Rolling Resistance coefficient

$$\mathbf{F(p) = (mg/2) \times \sin 15 + \mu N}$$

$$\mathbf{N = (mg/2) \times \cos 15}$$

15 degree → angle of inclination

$$\mathbf{F(tr) = \mu(t) \times mg}$$

$\mu(t)$ → Adhesion coefficient

Torque Γ :

$$\mathbf{\Gamma = F(t) \times r}$$

Speed N:

$$\omega = v/r$$

$r \rightarrow$ mean wheel radius

$$\omega = 2\pi N \div 60$$

Power P:

$$P = 2\pi N T \div 60$$

$$P = 14.4 \text{ bhp}$$

Vehicle Selection According To Calculations:

Activa: $m = 105 \text{ kg}$

Torque 10.12 Nm 5000rpm

Power 8.6 bhp 6500 rpm

Pulsar: $m = 150 \text{ kg}$

Torque 18.55 Nm 7000rpm

Power 20.64 BHP 850 rpm

Tata Nano: $m = 800 \text{ kg}$

Torque 51 Nm 4000rpm

Power 38 bhp

Vespa Vxl: $m = 110 \text{ kg}$

Torque 11.5 Nm 5500rpm

Power 11.4 bhp 7000 rpm

Aprilia SR150: $m = 122 \text{ kg}$

Torque 11.4 Nm 5000rpm

Power 10.25bhp 6750 rpm

As per the required power calculated we had to select a vehicle which match with our required power. We had found many vehicle whose power was as per our requirement and also we have to avoid gear and clutch arrangement. The budget of our project is low so we have selected Aprilia SR150 which is enough to carry the require loads.

16 QUICK FACTS **aprilia SR150**

1 154.8cc, 1-Cylinder
4-STROKE, AIR-COOLED

2 **Automatic CVT**
GEARBOX

3 10.4BHP @ 6750 rpm
MAX. POWER

4 11.4NM @ 5000 rpm
MAX. TORQUE

5 220MM DISC
FRONT BRAKE

6 140MM DRUM
REAR BRAKE

7 32MM Telescopic Forks
FRONT SUSPENSION

8 **Shock Absorber**
REAR SUSPENSION

9 120/70-14"
FRONT TYRE

10 120/70-14"
REAR TYRE

11 6.5LTRS
FUEL TANK

12 122KG
KERB WEIGHT

13 100+KMPH
TOP SPEED

14 775MM
SEAT HEIGHT

15 22August
LAUNCHED IN INDIA

16 ₹65,000
PRICE (EX-SHOWROOM)

Powerful Sports Scooter

Please link back to original source at Maxabout.com in case you republish this image. All Company & brand names, trademarks & logos are property of their respective owners. Prices, specifications & features are indicative only. Contact at info@maxabout.com for suggestions & feedback.

NAVI MUMBAI - INDIA

Figure 4.1. Aprilia SR150



Chapter 05
Project overview

5.1 Design objective

Design objectives of chassis are:

- Provide full protection of the driver, by obtaining required strength and torsional rigidity, while reducing weight through different tubing selection.
- Improve driver comfort by providing more lateral space in the driver compartment.
- Deciding the cost efficiency of such item in term of large scale manufacturing.
- The product can prove to be very efficient in all the aspect such as cost, drivability, maintenance, easy usage, safety.

5.1.1 Chassis design

The chassis is the most important aspect of a vehicle. The chassis of such vehicle is either preferred to be made up of hollow pipes or super tubular cross section so as to make it light weight and shock absorbent.

Dimension of chassis

Overall width	= 30inch
Overall length	=59inch
Ground clearance	=12.5inch
Weight capacity	= more than 200kg
Material	= AISI-1018

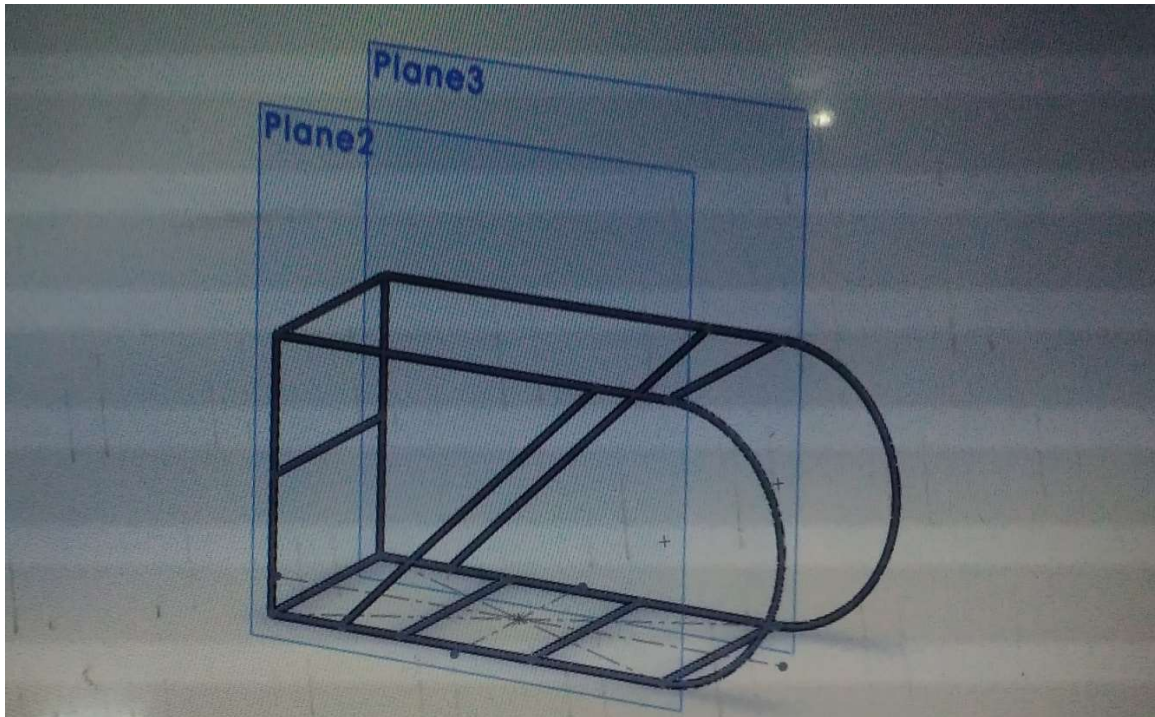

Figure 5.1. Model of side car in solid works

Design team really worked hard on the chassis design by considering various factors essential for design such as Stability, Aerodynamics, Centre of gravity, Mobility, Compatibility etc.

Mostly they have to keep the handicap person in mind, his comfort the ways to overcome his weakness as for him we are designing this dual control system vehicle. We used Solid works for designing it.

Handicap person uses his electric wheel chair to go from one place to another as he can't move without it. So, the team have to design the side car according to the dimensions of his electric wheel chair. The hardest part was to overcome the wheelchair's weight which is about 200kg including him. The team managed to achieve it by calculations and literature survey.

For handicap person to get on the side car with his electric wheel chair the team designed a ramp with an aluminium base to overcome its weight. Team had to design in such a way that the angle of the ramp should not exceed the angle, the wheel chair can travel. Chassis is both secure and comfortable for the handicap person.

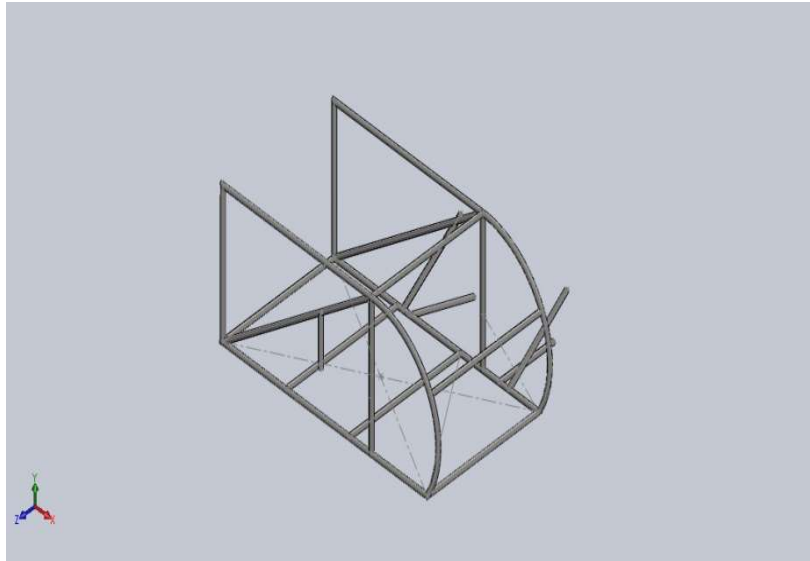

Figure5.2 Chassis model on solid works

5.1.2 Chassis prototype

A prototype is a representation of a design produced before the final solution exists. It allows you and potentially your future customers to understand the product. Prototype models are often used for photo shoots, trade shows and exhibitions, customer feedback, and design verification purposes.

Benefit of making prototype of chassis:

One of the crucial stages that remain part of the product development cycle involves the development of a working model which allows you to:

- Test various design features
- Verify design functionality
- Review initial product shapes or branding images
- Elicit feedback from customers or early adopters
- Use the prototype as a test-bed for developing additional features
- Identify issues as early as possible within the development stage and before going to production



Figure 5.3. Prototype of chassis





5.2 Profile cutting

Pipe cutting, or pipe profiling, is a mechanized industrial process that removes material from pipe or tube to create a desired profile. Typical profiles include straight cuts, mitres, saddles and midsection holes. These complex cuts are usually required to allow a tight fit between two parts that are to be joined via arc welding.

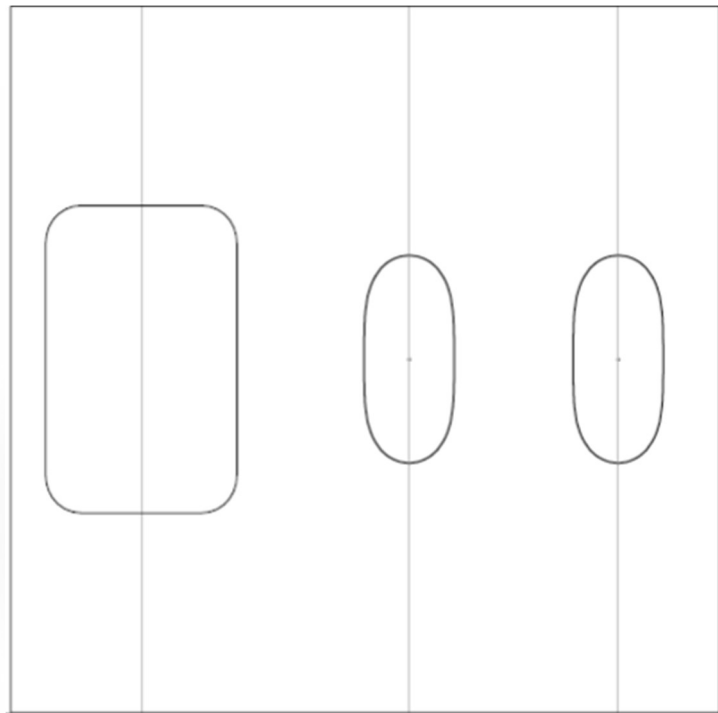
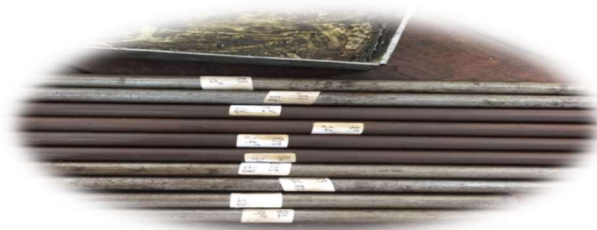
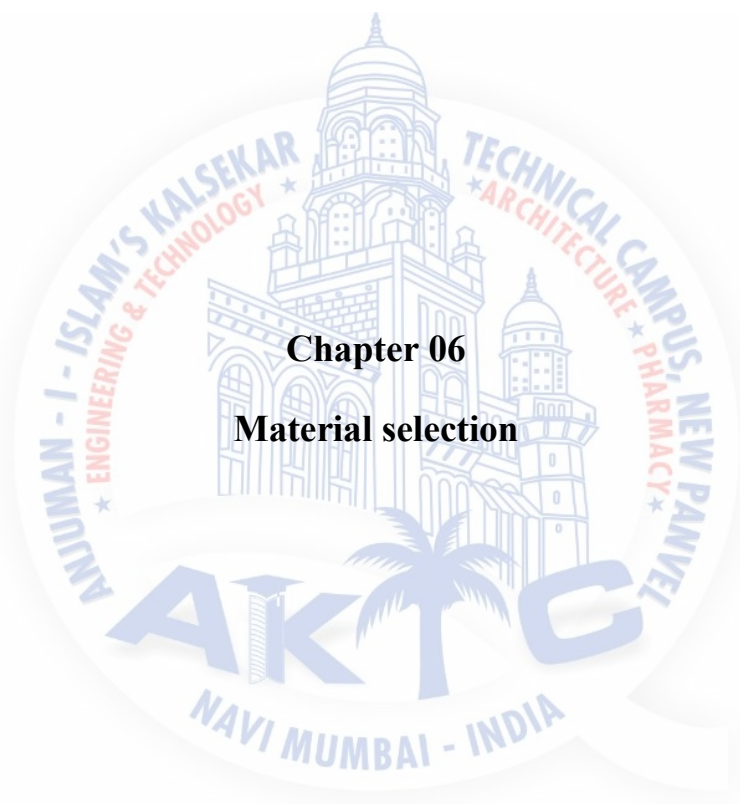

Figure 5.4. Profile of flange
NAVI MUMBAI - INDIA





Chapter 06
Material selection

6.1 Material Selection

The chassis is made up of AISI-1018. This material was selected due to its good combination of all of the typical traits of steel strength, ductility, and comparative ease of machining and weldability.

The properties of material are presented in the table

PROPERTIES	VALUE
Modulus of elasticity	200MPa
Hardness, Brinell	126
Tensile strength, Ultimate	440MPa
Elongation at break (in 50mm)	15.0%
Bulk modulus	140GPa
Poissons Ratio	0.290
Shear Modulus	80GPa

Table 6.1 Material properties (AISI 1018)

The trailing arm, the front impact portion and the ramp is made up of material AISI 4130. The material is selected due its high strength and its resistance to impact. SAE-AISI 4130 steel is an alloy steel formulated for primary forming into wrought products. 4130 is the designation in both the SAE and AISI systems for this material. G41300 is the UNS number.

The properties of material AISI-4130 is shown below:

PROPERTIES	VALUE
Modulus of elasticity	190GPa
Hardness, Brinell	200GPa -300GPa
Tensile strength, Ultimate	560MPa-1040MPa
Elongation at break (in 50mm)	(18-26)%
Bulk modulus	140GPa
Poisons Ratio	0.290
Shear Modulus	73GPa

Table 6.2 Material properties (AISI 4130)

The material stainless steel A240 is used for the flange pipe which is used to connect the side car and the vehicle.

Yield strength	170MPa
Tensile strength	485MPa
Elongation	40%
Hardness	217BHN

Table 6.1 Material properties (stainless steel)



SLIP-ON FLANGE

Figure 6.1. Material for flange (stainless steel)

Aluminium Alloy sheet 5754 used for the ramp and the base of the side car. which has a thickness of 4mm. It is a very hard wearing and strong grade of aluminium, it has excellent corrosion resistance and will withstand sea water and much pollution. Grade 5754 is excellent for welding and cold working.



Figure 6.2. Aluminium sheet

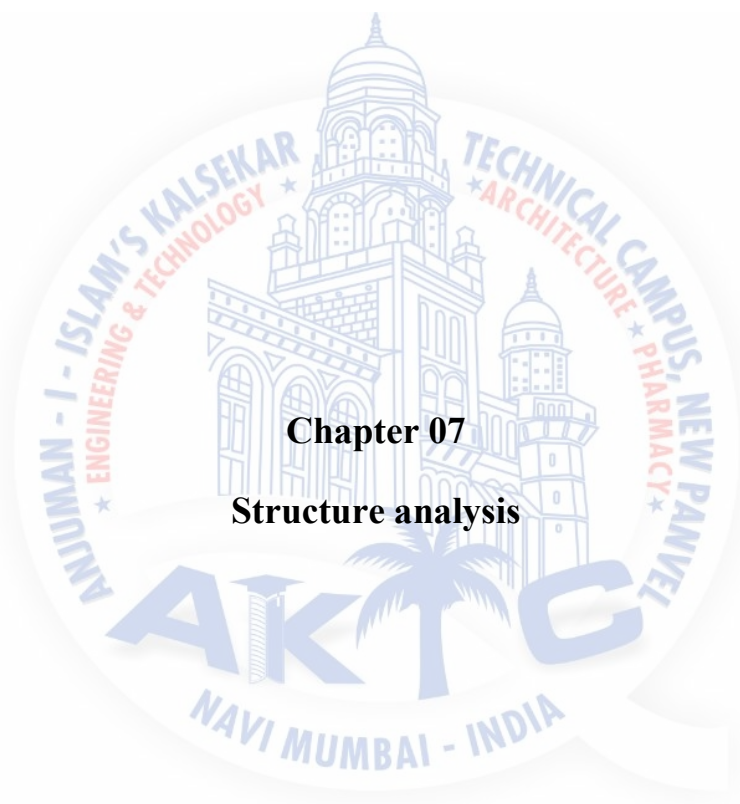

Chapter 07

Structure analysis

7.1 Introduction

After finalising our design on SOLIDWORKS and paper work, we have to analyse our design, for that we have to use a software. Mathematically or on papers it is very difficult to find out different types of forces, deflection, failure, etc. on our designed vehicle.

There are number of software's available for analysis of design such like AUTODESK Inventor, ANSYS, SOLIDWROKS, etc. But the SOLIDWORKS was the software which was the suitable for us to use it also it gives the better results than AUTODESK Inventor.

The purpose for using SOLIDWORKS, the software used is:

1. To find static structural analysis.
2. To find various forces acting on each member
3. To study Stresses.
4. To find the total deformation.
5. To get the solution on fatigue.

For completing the analysis on the specified software, we have to perform the following steps stated below as our model design is made by using a software as SOLIDWORKS.

1. Selection of material and applying material properties in analysis
2. mesh formation
3. Defining forces and supports
4. Solution for given system
5. Plotting the results

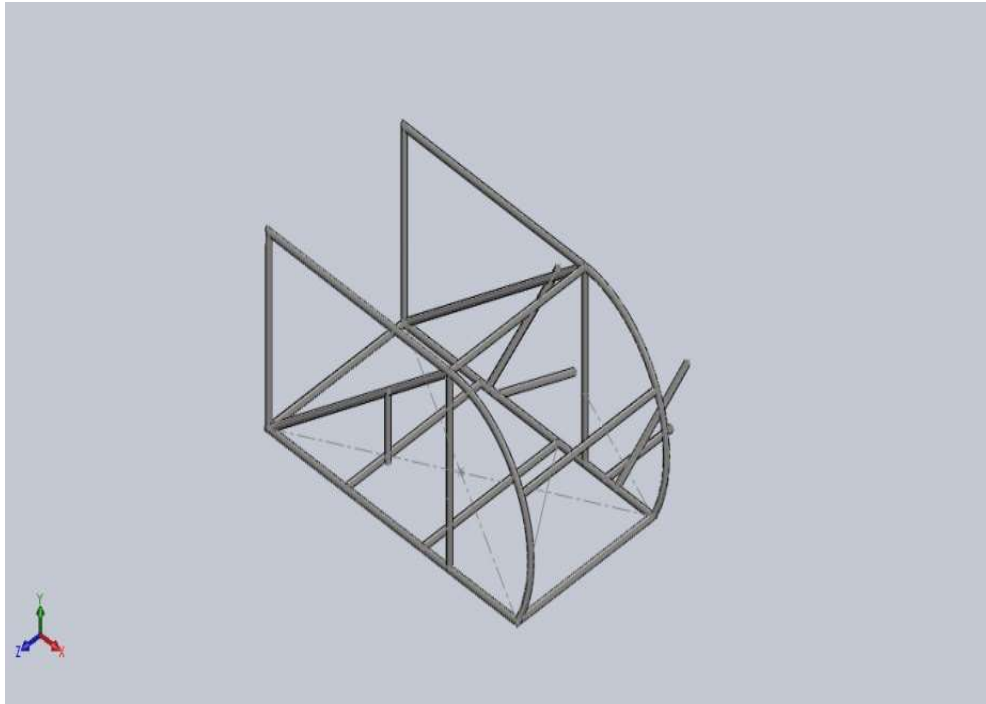

Figure 7.1 Model on solid works

7.1.1 Material Selection

In chapter 4 we studied a material AISI 1018. And based on results obtained by different resources, we selected the AISI 1018 as our vehicle material.

We gone to the material library our software i.e. ANSYS but in that library we did not find our chosen material, therefore we made a new material there as MS 1018 on the basis of our predefined material's standard properties.

When we assigned our made material to the model we found the different values of properties of our vehicle as given in the following table:

Material properties

Model Reference	Properties	Components
	<p>Name: AISI 1020</p> <p>Model type: Linear Elastic Isotropic</p> <p>Default failure criterion: Unknown</p> <p>Yield strength: 3.51571e+008 N/m²</p> <p>Tensile strength: 4.20507e+008 N/m²</p> <p>Elastic modulus: 2e+011 N/m²</p> <p>Poisson's ratio: 0.29</p> <p>Mass density: 7900 kg/m³</p> <p>Shear modulus: 7.7e+010 N/m²</p> <p>Thermal expansion: 1.5e-005 /Kelvin</p>	<p>SolidBody 1(Pipe 25.4X2(1)[14])(26 DEC weldments - Copy),</p> <p>SolidBody 2(Pipe 25.4X2(1)[1])(26 DEC weldments - Copy),</p> <p>SolidBody 3(Pipe 25.4X2(1)[2])(26 DEC weldments - Copy),</p> <p>SolidBody 4(Pipe 25.4X2(1)[22])(26 DEC weldments - Copy),</p> <p>SolidBody 5(Pipe 25.4X2(1)[17])(26 DEC weldments - Copy),</p>

Table 7.1. material properties in solid work

7.1.2 Meshing

Finite Element Analysis (FEA) provides a reliable numerical technique for analysing engineering designs. The process starts with the creation of a geometric model. Then, the program subdivides the model into small pieces of simple shapes called elements connected at common points called nodes. The process of subdividing the model into small pieces is called meshing. Finite element analysis programs look at the model as a network of interconnected elements.

Meshing is a crucial step in design analysis. The software automatically creates a mixed mesh of solid, shell and beam elements. The solid mesh is appropriate for bulky or complex 3D models. Shell elements are suitable for

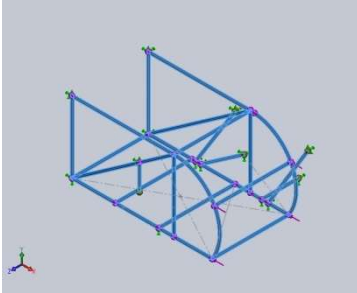
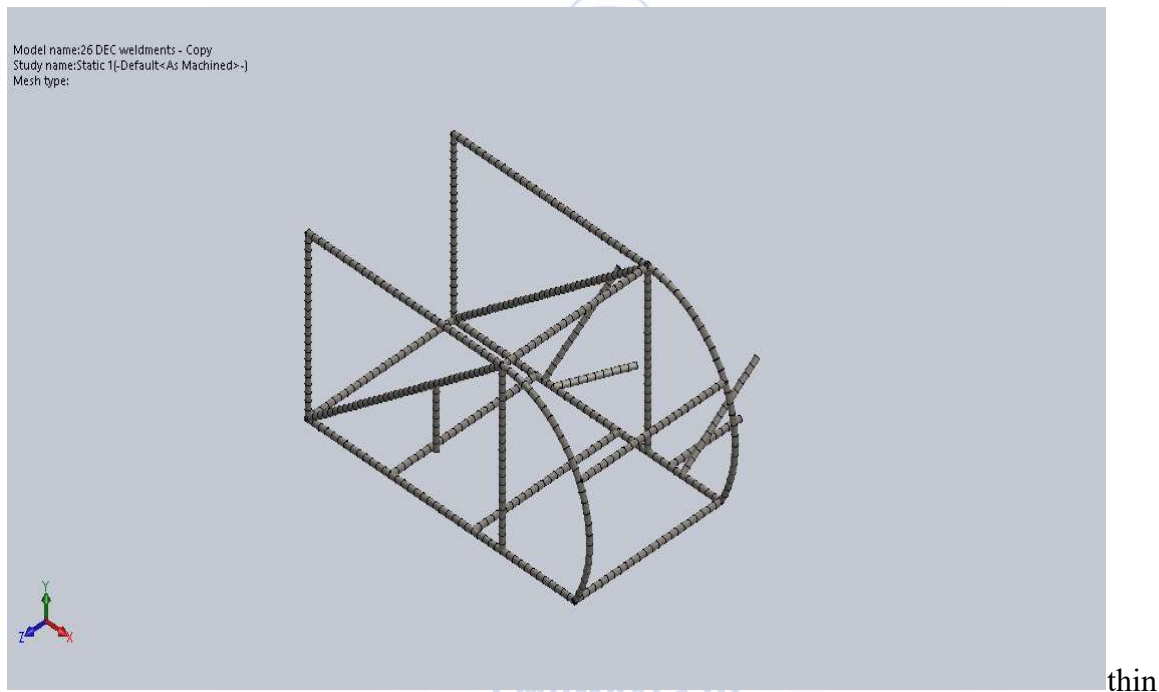

parts (like sheet metals). Beam elements are suitable for structural members.

The accuracy of the solution depends on the quality of the mesh. In general, the finer the mesh the better the accuracy.

Figure 7.2. Chassis model with meshing

Mashing information:

Total Nodes	633
Total Elements	570
Time to complete mesh(hh;mm;ss):	00:00:05
Computer name:	ADIL

*Table 7.2. mashing information***7.1.3 Supports and Forces****Supports**

To find out the magnitude of the forces, such like in mathematical problems we have to fixed the different types of supports such as fixed support, hinged support, roller support or pin support, etc. we have to defined it. Supports are thought of in terms of degree of freedom (DOF) available for the elements used. Supports, regardless of actual names, are always defined in terms of degree of freedom. Supports having a direction components can be defined in global or local coordinate system.

In our model we have fixed the two members linked with the forks of front and rear wheels as fixed supports such that a square horizontal bar with steering bar to which the front forks are joined and a horizontal square bar of main chassis frame to which the rear forks are attached. Since these are linked with the wheels that is they are resting or their loads are acting directly to the ground. The different loads are shown in fig below.

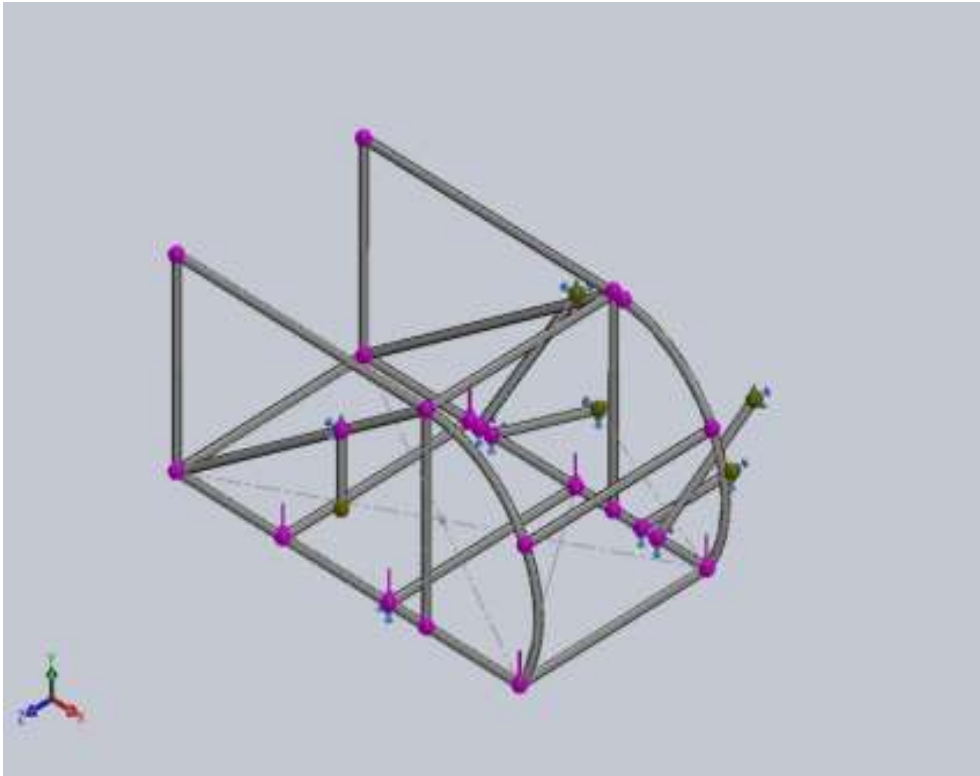

Figure 7.3. model with fixed support (static test)

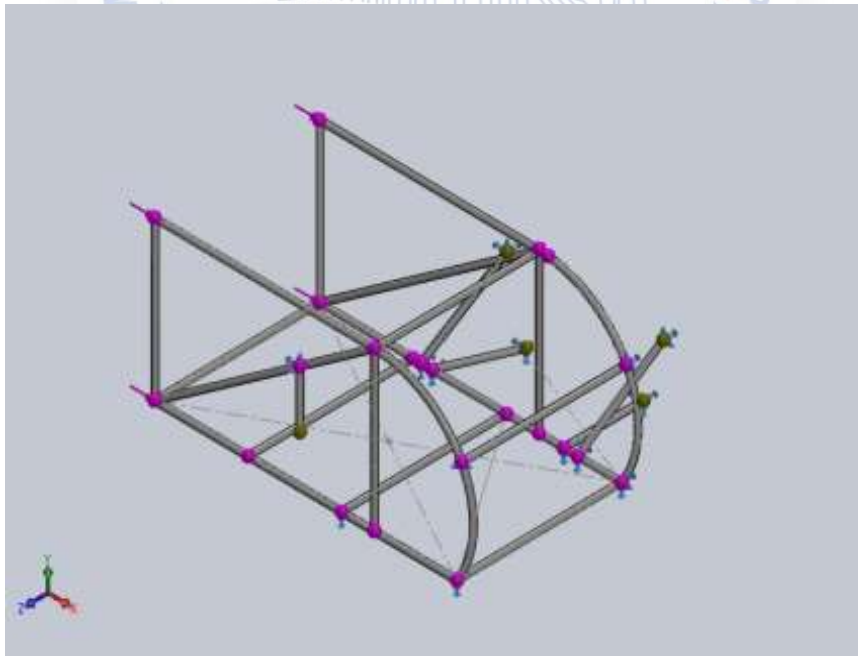

Figure 7.4 model with fixed support (static test)

Forces (Loads)

These are the actual reasons for the failure of any system. There are different types of loads acting on the entire system which are as follows:

1. **Inertial loads:**

These loads act on the entire system where density is required for mass calculations and these are only loads which act on defined point masses.

2. **Structural loads:**

Forces or moments acting on parts of system.

3. **Structural supports:**

Constraints that prevent movements on certain regions.

4. **Thermal loads:**

The thermal loads which result in a temperature field causing thermal expansion or contraction in the model.

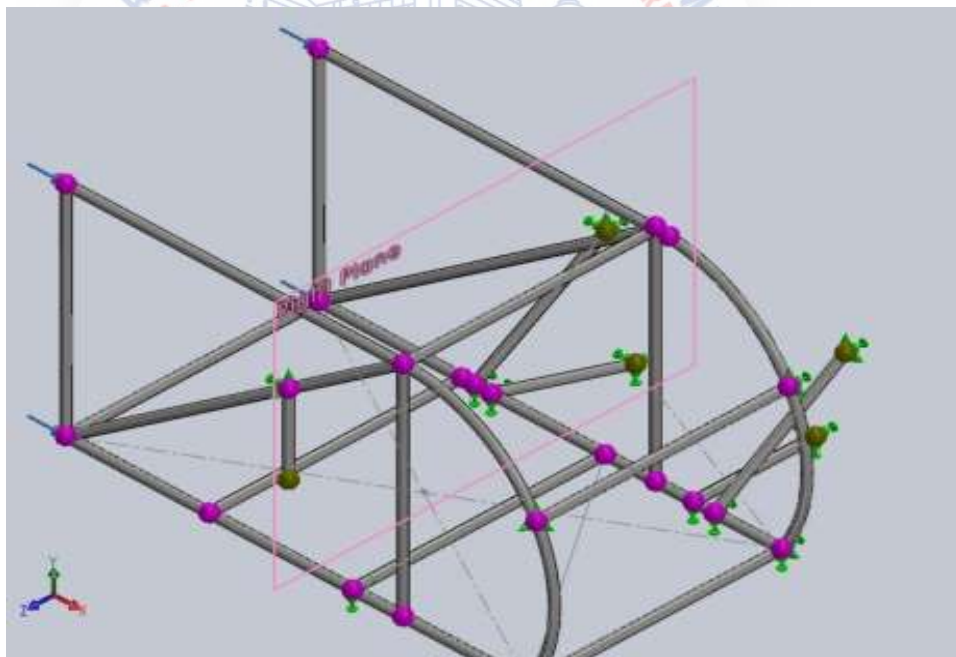

Figure 7.5 Forces applied on model

Load name	Load Image	Load Details	
Force-1		Entities:	1 plane(s), 4 Joint(s)
		Reference:	Right Plane
		Type:	Apply force
		Values:	2000N

Table 7.3. load details

7.1.4 Solution information

For solution we have selected results of analysis to display the different stresses, deformations, graphs (linear or non-linear) etc.

1. Front impact test

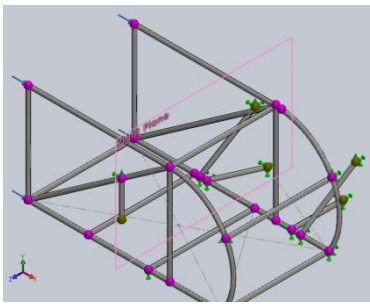
Name	Type	Min	Max
Stress1	TXY: Shear in Y Dir. on YZ Plane	0 N/m ²	8.99473e+007
		Element: 24	N/m ²
			Element: 396

Table 2.4 stress result (front impact test)

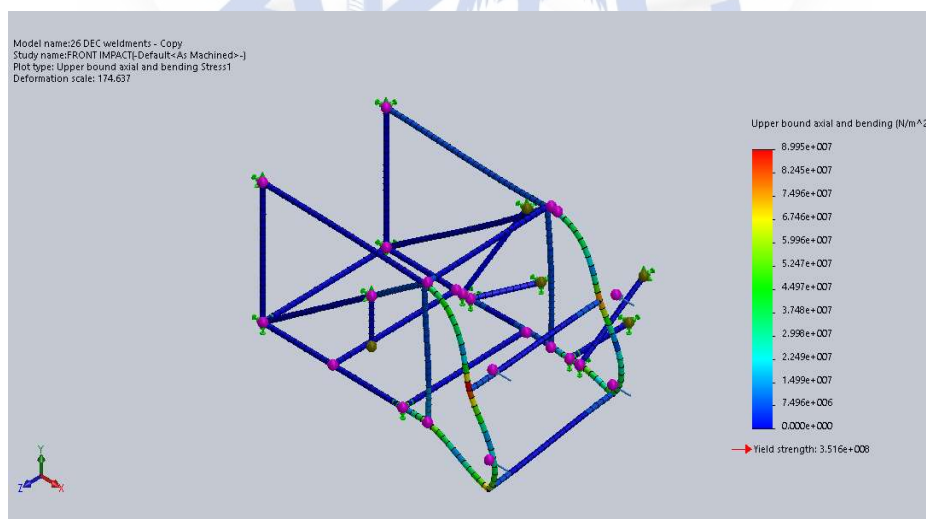

Figure 7.6. FRONT IMPACT-Stress-Stress I

Name	Type	Min	Max
Displacement1	URES: Resultant Displacement	0 mm Node: 1	1.11419 mm Node: 396

Table 7.5 displacement result (front impact test)

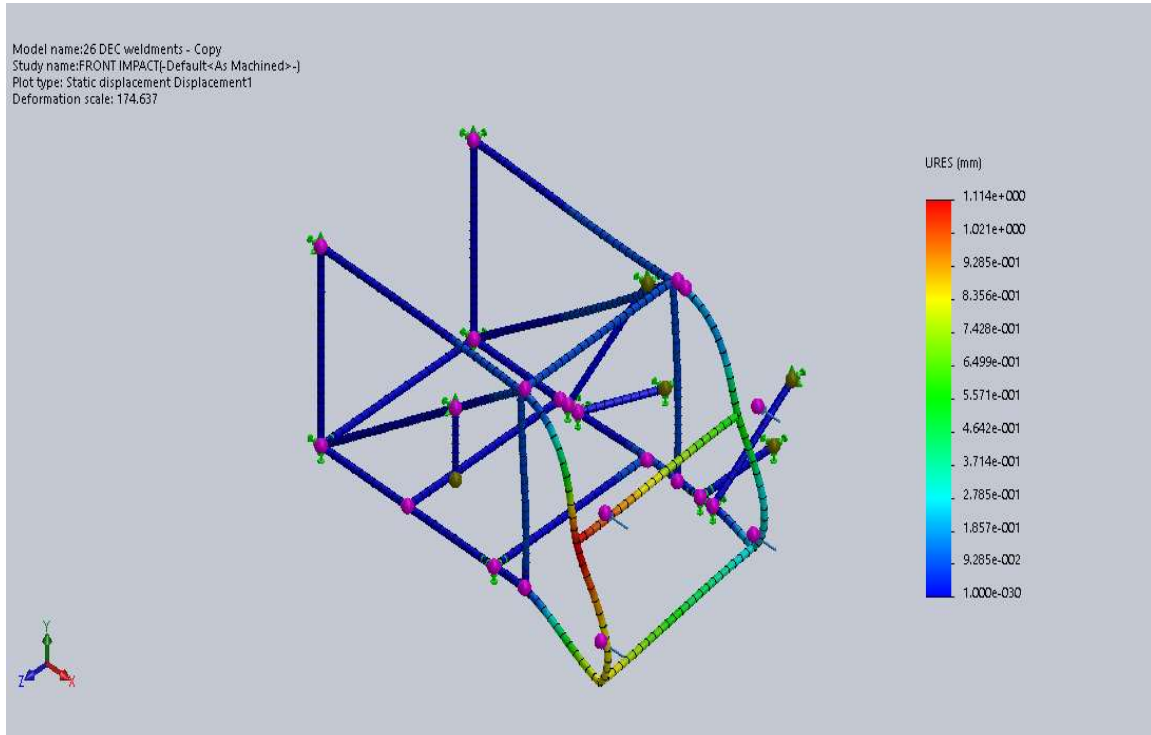

Figure 7.7 FRONT IMPACT-Displacement-Displacement1



2. Rear impact test

Name	Type	Min	Max
Stress1	TXY: Shear in Y Dir. on YZ Plane	0 N/m ² Element: 47	7.7027e+007 N/m ² Element: 497

Table 7.6 stress result (rear impact test)

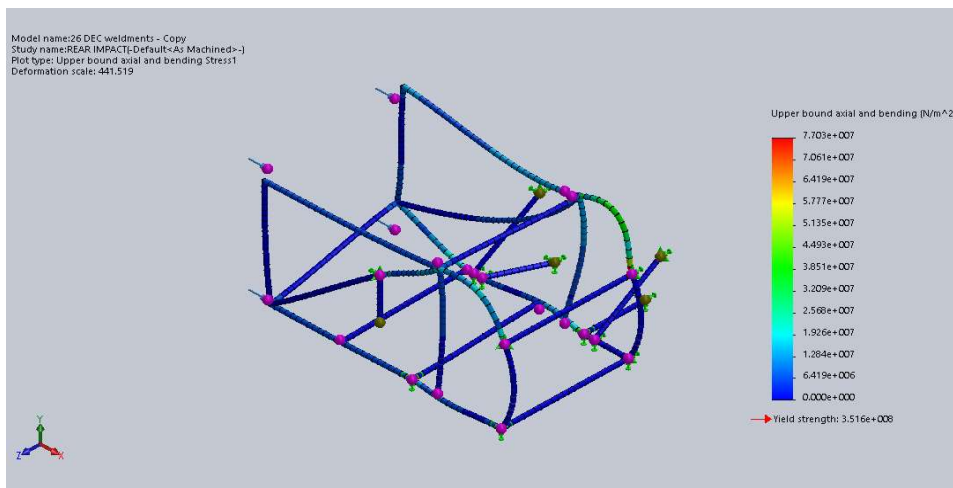

Figure 7.8. REAR IMPACT-Stress-Stress1

Name	Type	Min	Max
Displacement1	URES: Resultant Displacement	0 mm Node: 1	0.446381 mm Node: 401

Table 7.7 displacement result (rear impact test)

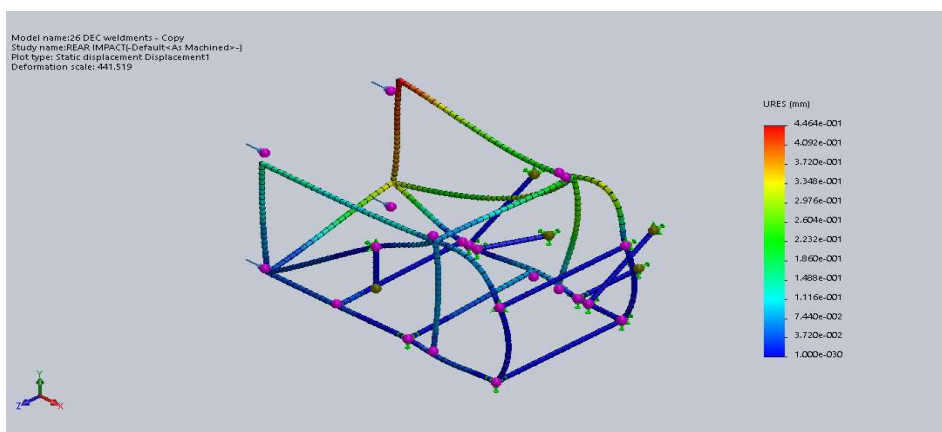

Figure 7.9 REAR IMPACT-Displacement-Displacement1

3. static test

Name	Type	Min	Max
Stress1	TXY: Shear in Y Dir. on YZ Plane	0 N/m ² Element: 129	6.01034e+007 N/m ² Element: 423

Table 7.8 stress result (static impact test)

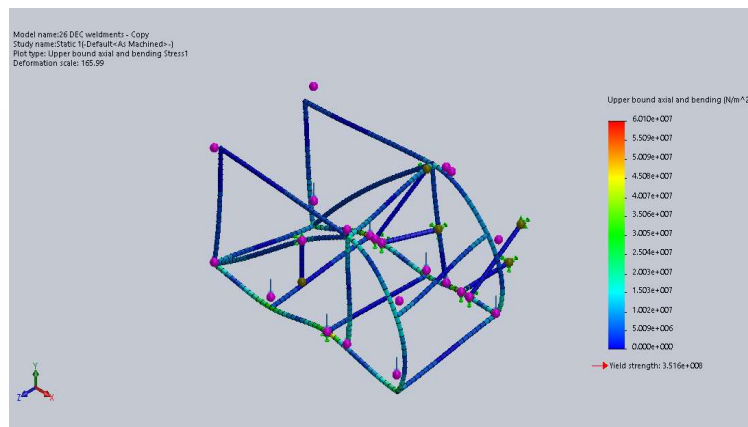

Figure 7.10 Copy-Static 1-Stress-Stress1

Name	Type	Min	Max
Displacement1	URES: Resultant Displacement	0 mm Node: 1	1.09163 mm Node: 377

Table 7.9 displacement result (static impact test)

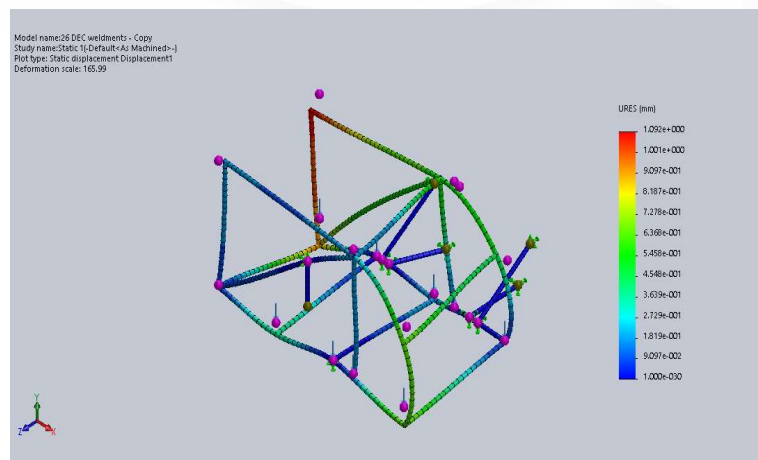
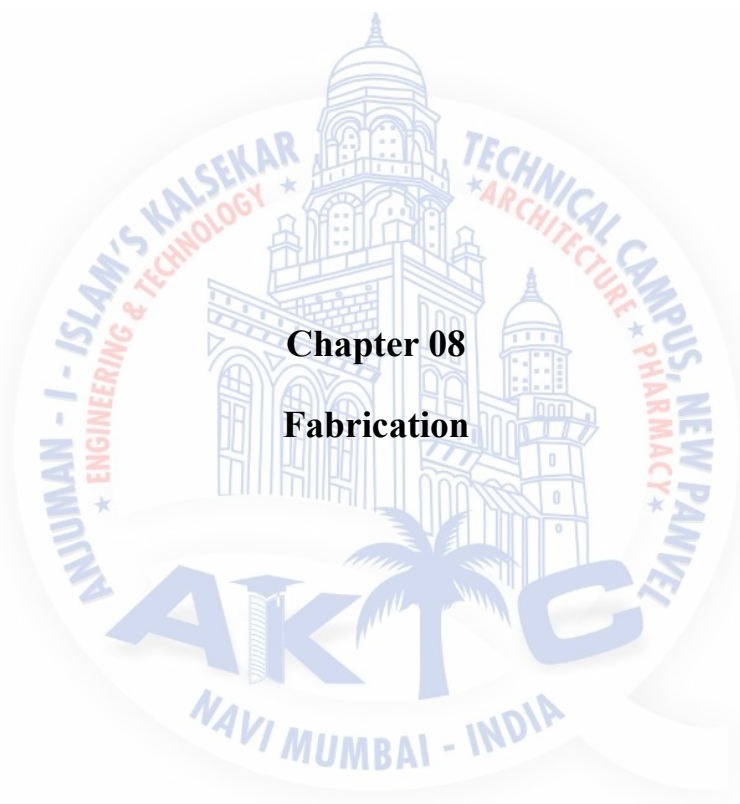

Figure 7.11. Copy-Static 1-Displacement-Displacement1



Chapter 08
Fabrication

- Various cutting wheel and grinding wheel is used for fabrication.
- Large size cutting wheel is used for metal cutting.
- Small size is used for hand grinder and hand cutting wheel.
- Electrode rod E6013 is used for welding.

8.1 Material Cutting



Figure 8.1. Material Cutting



8.2 Fitting and Welding

For welding we had used shielded metal arc welding (stick welding). The electrode that we had used is E6013. We weld at different current(ampere) condition.



Figure 8.23. Welding during fabrication



8.3 Final part



Figure 8.3. Assembly of vehicle



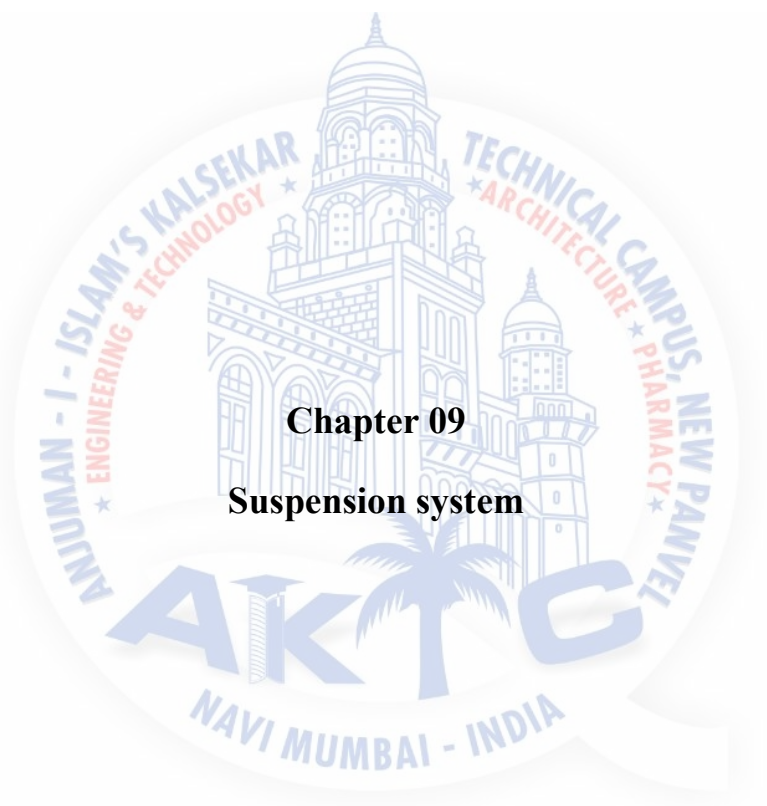

Chapter 09

Suspension system

9.1 Suspension system

We are using **independent suspension system**. Suspension is the system of tires, tire air, springs, shock absorbers and linkages that connects a vehicle to its wheels and allows relative motion between the two. Suspension systems must support both road holding/handling and ride quality, which are at odds with each other. The tuning of suspensions involves finding the right compromise. It is important for the suspension to keep the road wheel in contact with the road surface as much as possible, because all the road or ground forces acting on the vehicle do so through the contact patches of the tires. The suspension also protects the vehicle itself and any cargo or luggage from damage and wear. The design of front and rear suspension of a car may be different.

As we know that our vehicle is 3-wheeler vehicle in which we have select a 2-wheeler (Aprilia 150cc). To attach the side car a flange and some linkage are given and the third tyre is also used to support the side car



Figure 9.1 suspension (Aprilia SR150)

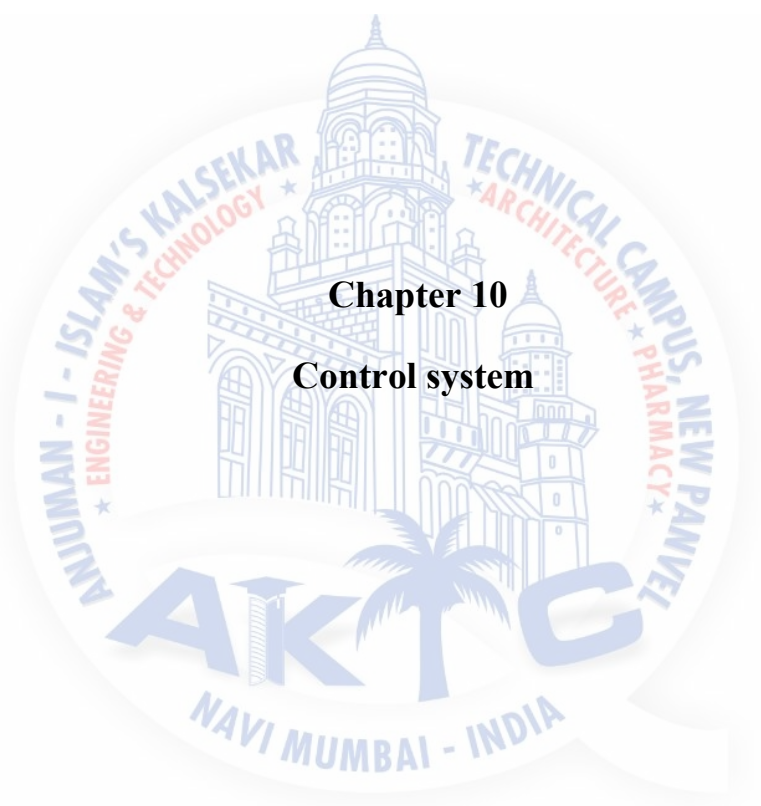

Chapter 10
Control system

As we know the subject has a disease called muscular dystrophy. In which the motor power of the subject goes on decreasing time to time. When we examined him, we observed that his leg does not work and the hand movement is little good as compared to the movement of leg.

10.1 Basic control required:

1. Steering
2. Acceleration
3. Brakes.

Previously controlling of steering was decided to be done using motors by giving special gear arrangement with the help of side mirror controlling switch used in cars.

Controlling of acceleration & brake will be done simultaneously using lever mechanism that is forward motion of joystick will lead to acceleration & backward motion will lead to braking of vehicle.

Automatic side mirrors in car

Basically, in cars this system is used to control side mirror motors for 4-way motion including horizontal as well as vertical direction.

Small switch is used to select the mirror which is to be operated.

Special gear arrangement will be done using single motor to turn the steering.

Motor will be controlled using this 4-way switch

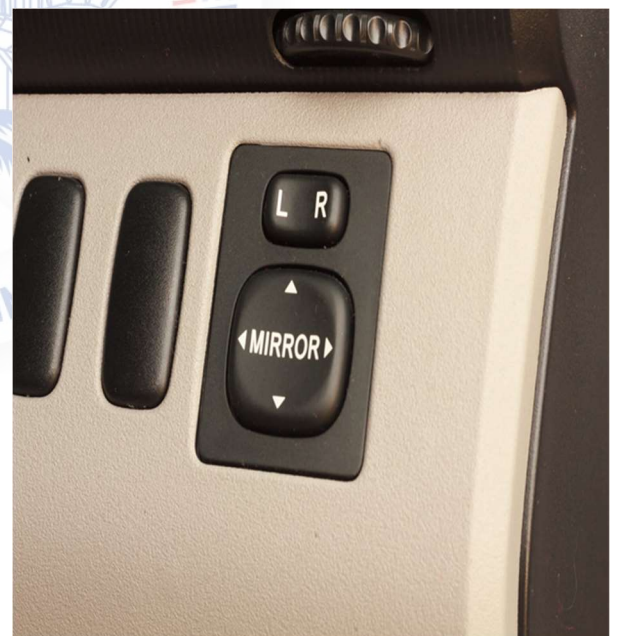

Figure 10.1. controlling of automatic side mirror in car

10.1.1 Braking system

The brake will be control by moving the hand bar in backward direction. By pulling the Lever in backward direction the mechanical cable will operate the back-drum brake of Aprilia SR150. The arrangement at the drum brake side will be as given in activa 4G front brake system as shown in the below image



Figure 10.2. dual brake in activa 4G

We will be replacing the Aprilia SR150 back drum brake Arm with the Arm shown in the above picture of Activa 4G. The Arm can be operated by both person.



Figure 10.3. Brake

10.1.2 Acceleration control:

The accelerator will be control by moving the Lever in forward direction. Due to this the cable will pull the accelerator arrangement on the engine side.



Figure 10.44. Acceleration

10.1.3 Steering Control:

The Switch on the top of bar will control the steering movement. The steering movement will be controlled by motor which can rotate in both clockwise and anticlockwise direction with the help of a joystick created or built using different electronic parts. The switch which is used to select the left and right mirror in car will be used for turning ON/OFF the steering control system on the patient side.

Motor mounting for controlling of steering



Figure 10.5. mounting of motor for controlling of steering

10.2 Ramp system

Ramp will be used to load or unload the subject into the sidecar. For controlling of ramp, we are using a high torque linear actuator with linkage shown in the figure. There are total four push button, two push buttons (green and red) inside the vehicle and two push buttons outside the vehicle for controlling the opening and closing of ramp. Green push button will be used for opening the ramp and red push button is used for closing the ramp.



Figure 10.6. linear actuator



Figure 10.7. Ramp in side car



10.3 Thing to be installed in the control system

1. Battery level indicator
2. Left & right indicator
3. Horn
4. Push button (starter)
5. Starter key
6. Kill switch

1. battery level indicator:

A Battery indicator is a device which gives information about a battery. This will usually be a visual indication of the battery's state of charge. It is particularly important in the case of a battery electric vehicle.

Some automobiles are fitted with a battery condition meter to monitor the starter battery. This meter is, essentially, a voltmeter but it may also be marked with coloured zones for easy visualization.



Figure 10.8. Battery level indicator (12v)

2. Left and right indicator:

Indicator lights are amber in colour and can be located at the front, the rear and sometimes at the side of the car on both the left and right-hand sides. You **use** your indicators to show an intended change of direction, whether turning left or right or moving out into traffic.



Figure 10.9. left right indicator switch

3. Horn:

A horn is a sound-making device that can be equipped to motor vehicles, buses, bicycles, trains. The sound made usually resembles a "honk". The vehicle operator uses the horn to warn others of the vehicle's approach or presence, or to call attention to some hazard.

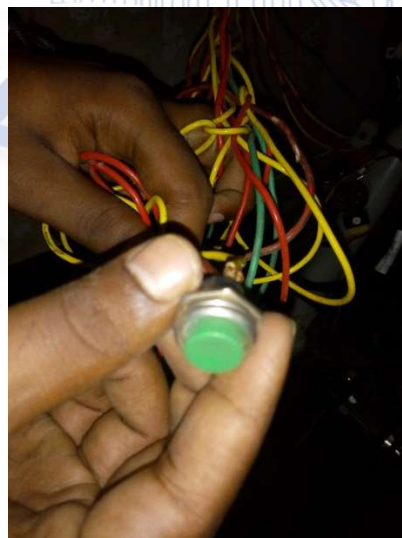

Figure 10.10. horn (button)

4. Push button (starter):

A starter (also self-starter, self, cranking motor, or starter motor) is a device used to rotate (crank) an internal-combustion engine so as to initiate the engine's operation under its own power. Starters can be electric, pneumatic, or hydraulic. In the case of very large engines, the starter can even be another internal-combustion engine.



Figure 10.11. push button

5. Ignition switch (starter switch):

An ignition switch or starter switch is a switch in the control system of an internal combustion engine motor vehicle that activates the main electrical systems for the vehicle. Besides providing power to the starter solenoid and the ignition system components (including the engine control unit and ignition coil) it also usually switches on power to many "accessories" (radio, power windows, etc.). The ignition switch usually requires a key be inserted that works a lock built into the switch mechanism. It is frequently combined with the starter switch which activates the starter motor. The ignition locking system may be bypassed by disconnecting the wiring to the switch and manipulating it directly; this is known as hotwiring.



Figure 10.12. ignition switch

6. kill switch:

A kill switch, also known as an emergency stop (e-stop) and as an emergency power off (EPO), is a safety mechanism used to shut off machinery in an emergency, when it cannot be shut down in the usual manner. Unlike a normal shut-down switch or shut-down procedure, which shuts down all systems in order and turns off the machine without damage, a kill switch is designed and configured to abort the operation as quickly as possible (even if it damages the equipment) and to be operated simply and quickly (so that even a panicked operator with impaired executive functions or a by-stander can activate it). Kill switches are usually designed to be noticeable, even to an untrained operator or a bystander.



Figure 10.13. kill switch

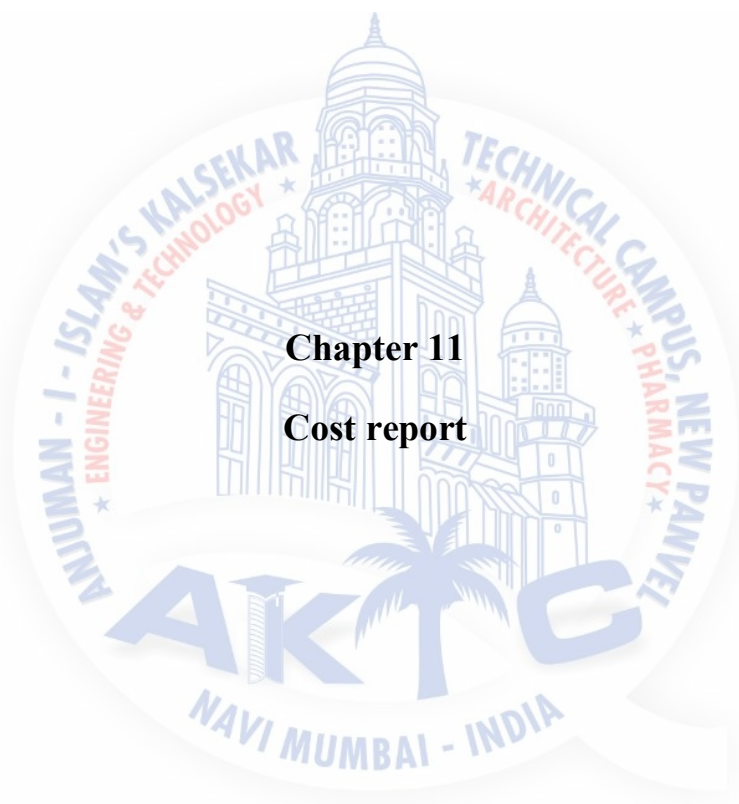

Chapter 11
Cost report

11.1 Cost report:

Sr.no,	Particular	Price (Rs.)
1.	Aprilia SR50	82,500
2.	Pipe material	8,360
3.	Ramp material(aluminium)	6,000
4.	Brake, tyre assembly	7,500
5.	Welding rods	3,200
6.	Acrylic	2,650
7.	Shock up	2,200
8.	Paint	1,000
9.	Accessories	13,500
10.	Nut, bolt	2,600
11.	Electricals	3,800
12.	Fare	1,000
13.	Petrol	2,000
14.	Motor driver	2,500
	Total	1,38,810

Table 11.1. cost report

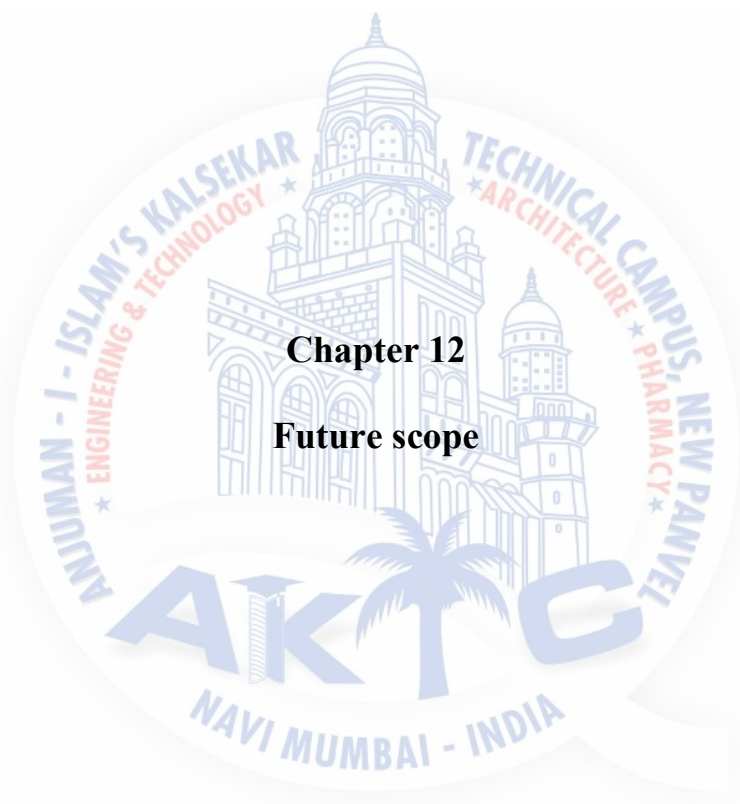

Chapter 12
Future scope

12.1 Future scope:

- Wobbling of steering can be reduce.
- Steering effort can be reduced.
- Load distribution can be balance.
- Chassis can be modified.
- Arrangements can be made to reduce the overhanging of the side car in the front end.
- Folding mechanism can be adopted for ramp.



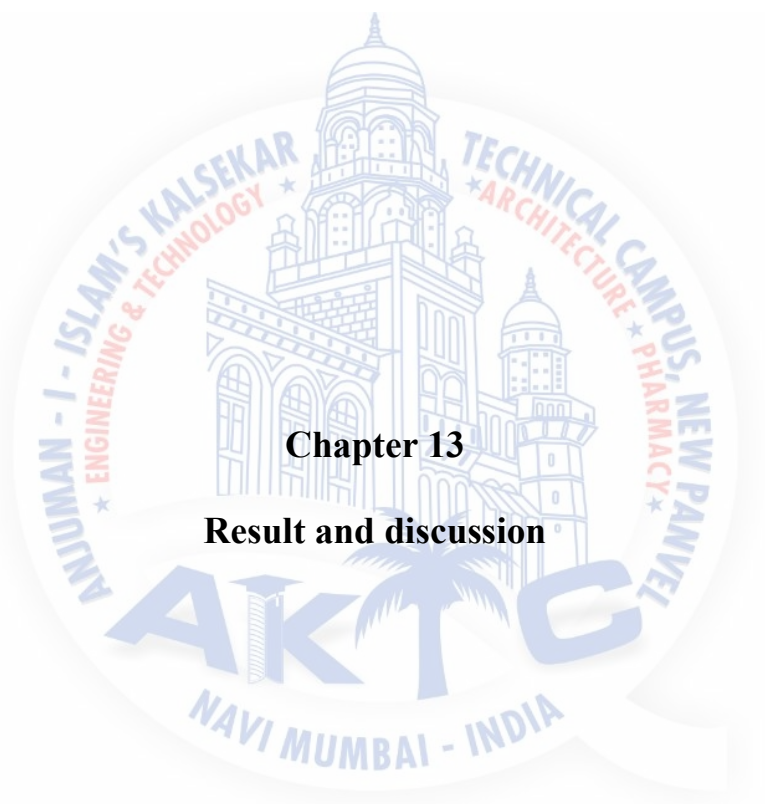

Chapter 13

Result and discussion

13.1 Result and discussion

The key to good chassis design is that the further ass is away from the neutral axis the more rigid it will be. This one sentences is the basics of automotive chassis design.

This study attempted to analyse stress on chassis design using SOLIDWORKS. This is important because the simulation data are useful for further design improvement and subsequently leads to cost effectiveness.

Our main aim is to mobilize the handicapped person who is suffering from different disabilities and serve such kind of product to our society.



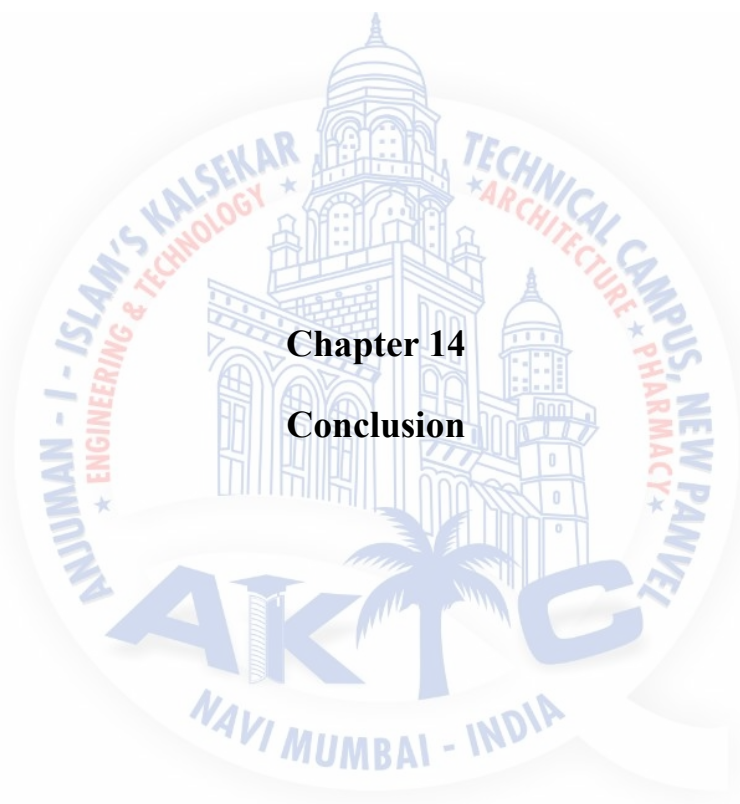

Chapter 14
Conclusion

14.1 Conclusion

With all our hard work and analysis using SOLIDWORKS we successfully carried out our project of making a Dual control system vehicle with all the comfort and abilities to drive it by a handicap person with such disabilities as described above.





Figure 14.1. front side of the vehicle



Figure 14.2. back side of the vehicle

References

1. <http://www.ijstr.org/final-print/aug2015/Motor-Torque-Calculations-For-Electric-Vehicle.pdf>
2. Car customization for Physically Challenged
<https://m.cartrade.com/blog/2011/auto-guides/car-customization-for-the-physically-challenged-172.html>
3. http://www.ijarse.com/images/fullpdf/1437994166_36_Research_Paper.pdf

science direct:

journal paper

4. <https://www.sciencedirect.com/science/article/pii/S2351978915008550>
5. <http://www.youtube.com>

