

**A PROJECT REPORT**  
**ON**  
**“MAINTENANCE OF 220KV ELECTRICAL EQUIPMENT UNDER**  
**ADANI ELECTRICITY ”**

**Submitted to**

**UNIVERSITY OF MUMBAI**

**In Partial Fulfilment of the Requirement for the Award of BACHELOR’S**  
**DEGREE IN**

**ELECTRICAL ENGINEERING**

**BY**

<b>KHAN AZHARUDDIN</b>	<b>15EE16</b>
<b>SHAIKH GULAM JILANI</b>	<b>15EE39</b>
<b>CHAUDHARY MUSHTAQUE</b>	<b>14EE30</b>
<b>SAYED MOHD JAVED</b>	<b>14EE34</b>

**UNDER THE GUIDANCE OF**  
**PROF. YAKUB KHAN**

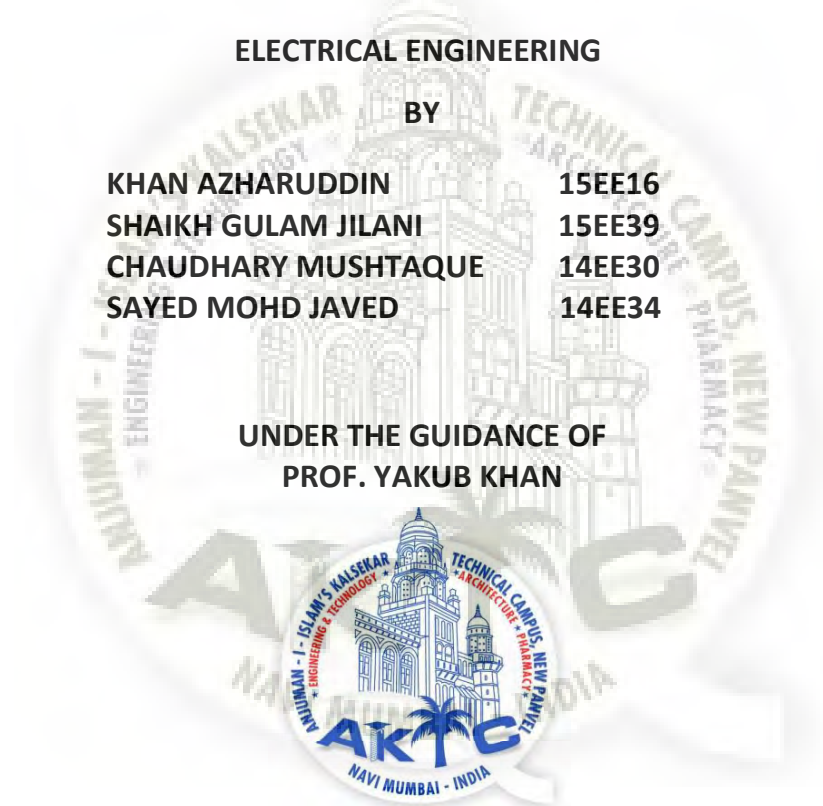

**DEPARTMENT OF ELECTRICAL ENGINEERING**

**Anjuman-I-Islam’s Kalsekar Technical Campus**  
**SCHOOL OF ENGINEERING & TECHNOLOGY**

Plot No. 2 & 3, Sector - 16, Near Thana Naka,

Khandagaon, New Panvel - 410206

**2018-2019**

**AFFILIATED TO**

**UNIVERSITY OF MUMBAI**

**A PROJECT REPORT ON**  
**“MAINTENANCE OF 220KV ELECTRICAL EQUIPMENT UNDER ADANI**  
**ELECTRICITY”**

**Submitted to**

**UNIVERSITY OF MUMBAI**

**In Partial Fulfilment of the Requirement for the Award of**  
**BACHELOR’S DEGREE IN**  
**ELECTRICAL ENGINEERING**

**BY**

<b>KHAN AZHARUDDIN</b>	<b>15EE16</b>
<b>SHAIKH GULAM JILANI</b>	<b>15EE39</b>
<b>CHAUDHARY MUSHTAQUE</b>	<b>14EE30</b>
<b>SAYED MOHD JAVED</b>	<b>14EE34</b>

**UNDER THE GUIDANCE OF**  
**PROF. YAKUB KHAN**

**DEPARTMENT OF ELECTRICAL ENGINEERING**

**Anjuman-I-Islam’s Kalsekar Technical Campus**  
**SCHOOL OF ENGINEERING & TECHNOLOGY**

**Plot No. 2 & 3, Sector - 16, Near Thana Naka,**

**Khandagaon, New Panvel - 410206**

**2018-2019**

**AFFILIATED TO**



# Anjuman-i-Islam's Kalsekar Technical Campus

Department of Electrical Engineering

SCHOOL OF ENGINEERING & TECHNOLOGY



## CERTIFICATE

This is certify that the project entitled

**“MAINTENANCE OF 220KV ELECTRICAL EQUIPMENT UNDER  
ADANI ELECTRICITY “**

submitted by

<b>KHAN AZHARUDDIN</b>	<b>15EE16</b>
<b>SHAIKH GULAM JILANI</b>	<b>15EE39</b>
<b>CHAUDHARY MUSHTAQUE</b>	<b>14EE30</b>
<b>SAYED MOHD JAVED</b>	<b>14EE34</b>

is a record of bonafide work carried out by them, in the partial fulfilment of the requirement for the award of Degree of Bachelor of Engineering (Electrical Engineering) at *Anjuman-I-Islam's Kalsekar Technical Campus, Navi Mumbai* under the University of MUMBAI. This work is done during year 2018-2019, under our guidance.

**Date: / /**

**(Prof. YAKUB KHAN)**  
Project Supervisor

**(Prof. IFTEKHAR PATEL)**  
Project Coordinator

**(Prof. SAYED KALEEM)**  
HOD, Electrical Department

**DR. ABDUL RAZAK HONNUTAGI**  
Director

**External Examiner**

## ACKNOWLEDGEMENT

The internship opportunity we had with ADANI ELECTRICITY was a great chance for learning and professional development. Therefore, we consider ourselves as a very lucky individual as we were provided with an opportunity to be a part of it. We are also grateful for having a chance to meet so many wonderful people and professionals who led us through this training period. We also want to deeply thank the **PROF YAKUB KHAN** for giving this chance to us.

Bearing in mind previous we are using this opportunity to express our deepest gratitude and special thanks to **SH SAYED JAFAR KHAN (Dy General Manager)**, **SH DILIP DEVASTHALE (Addl Vice President)** and his colleagues who in spite of being extraordinarily busy with their duties, took time out to train us and guide us through the right path and helped us with the intensive knowledge about professional life.

It is our radiant sentiment to place on record our best regards, deepest sense of gratitude to **SH DEVIDAS VISPUTE (Asst Vice President)** for their careful and precious guidance which were extremely valuable for our study both theoretically and practically. We would like to express deepest appreciation towards **DR. ABDUL RAZAK HONNUTAGI**, Director, AIKTC, Navi Mumbai, **PROF. SAYED KALEEM**, Head of Department of Electrical Engineering and **Prof. IFTEKHAR PATEL**, Project Coordinator whose invaluable guidance supported us in completing this project.

At last we must express our sincere heartfelt gratitude to all the staff members of Computer Engineering Department who helped me directly or indirectly during this course of work.

KHAN AZHARUDDIN

SHAIKH GULAM JILANI

CHAUDHARY MUSHTAQUE

SAYED MOHD JAVED

## A- Project I Approval for Bachelor of Engineering

This project entitled “ **MAINTENANCE OF 220KV ELECTRICAL EQUIPMENT UNDER ADANI ELECTRICITY** ” by KHAN AZHARUDDIN (15EE16), SHAIKH GULAM JILANI (15EE39), CHAUDHARY MUSHTAQUE (14EE30), SAYED MOHD JAVED(14EE34) is approved for the degree of **Bachelor of Engineering in Department of Electrical Engineering.**

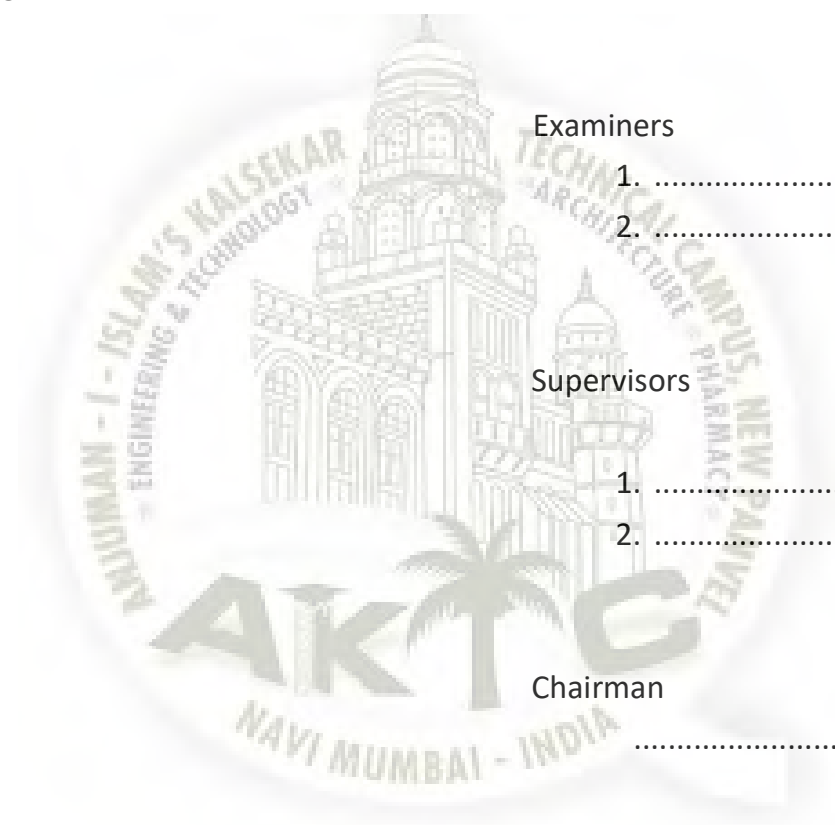

Examiners

- 1. ....
- 2. ....

Supervisors

- 1. ....
- 2. ....

Chairman

.....

## B- Declaration

I declare that this written submission represents my ideas in my own words and where others ideas or words have been included, I have adequately cited and referenced the original sources. I also declare that I have adhered to all principles of academic honesty and integrity and have not misrepresented or fabricated or falsified any idea/data/fact/source in my submission. I understand that any violation of the above will be cause for disciplinary action by the Institute and can also evoke penal action from the sources which have thus not been properly cited or from whom proper permission has not been taken when needed.

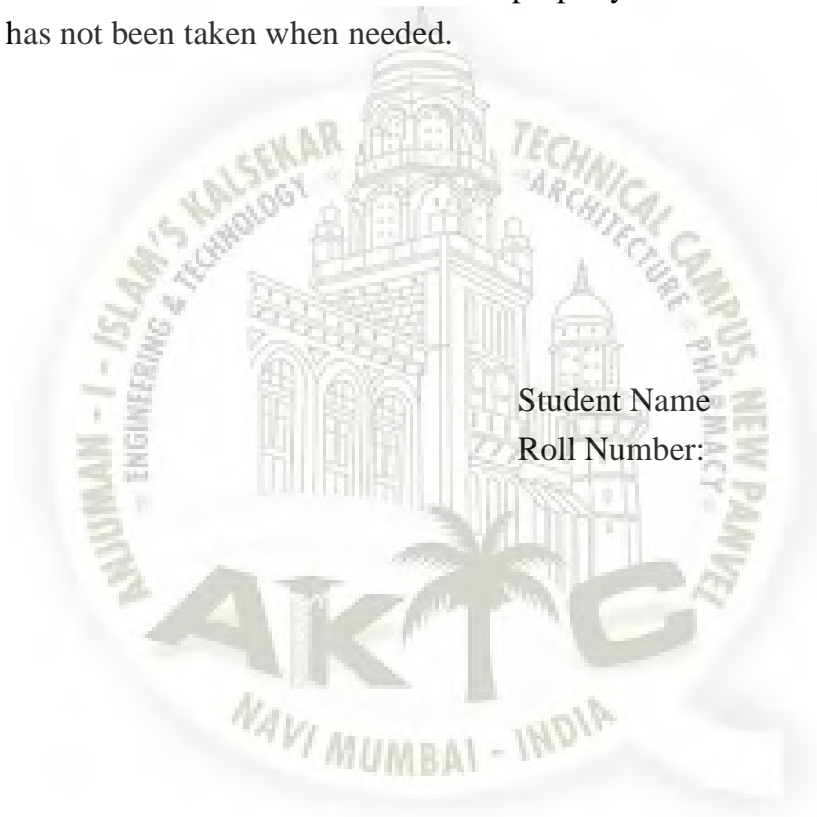

Student Name

Roll Number:



# Content

Acknowledgement	
Project I Approval for Bachelor of Engineering	
Declaration	
Table of Contents	
<b>1 Introduction</b>	<b>11-13</b>
1.1 Adani Power Limited	
1.2 History	
1.3 Operation	
1.4 Future Projects	
<b>2 Major Components in Electrical Substation &amp; There Working</b>	<b>14-20</b>
2.1 Electrical Power transformer	
2.2 Instrument Transformer	
2.3 Current Transformer	
2.4 Potential Transformer	
2.5 Conductor	
2.6 Insulator	
2.7 Isolator	
2.8 Busbar	
2.9 Lightning Arrester	
2.10 Circuit Breaker	
2.11 Relay	
2.12 Capacitor Bank	
<b>3 Define Electrical Maintenance</b>	<b>21-22</b>
3.1 Introduction	
3.2 Types of Maintenance	
3.2.1 types	
3.2.2 Preventive	
3.2.3 Corrective	
3.2.4 Predective	
<b>4 Maintenance of Transformer</b>	<b>23-25</b>



4.1	Daily Basis of Maintenance & Checking	
4.2	Monthly Basis of Maintenance of Transformer	
4.3	Half Yearly Maintenance	
4.4	Yearly Basis of Maintenance	
4.5	The Action to be Taken Once in 2 Year	
<b>5</b>	<b>Maintenance of Current Transformer</b>	<b>26</b>
<b>6</b>	<b>Maintenance of Voltage Transformer &amp; Capacitor Voltage Transformer</b>	<b>27</b>
6.1	Yearly basis of maintenance	
<b>7</b>	<b>Circuit Breaker Maintenance</b>	<b>28-29</b>
7.1	Bulk oil CB maintenance	
7.2	Minimum oil CB maintenance	
7.3	Maintenance of air blast CB	
7.4	SF6 CB maintenance	
<b>8</b>	<b>Maintenance of Relay</b>	<b>30-31</b>
<b>9</b>	<b>Electrical Isolator or Electrical Isolation Switch</b>	<b>32-34</b>
9.1	Definition of Isolator	
9.2	Types of Electrical Isolator	
9.3	Construction Features of Double Break Isolator	
9.4	Construction Features of Single Break Isolator	
9.5	Earthing Switches	
9.6	Operation of Electrical Isolator	
<b>10</b>	<b>Busbar Protection   Busbar Differential Protection Scheme</b>	<b>35-41</b>
10.1	Current Differential Function	51
10.2	Differential Protection of Sectionalized Bus	
10.3	DC Circuit of Differential Busbar Protection	
10.4	Voltage Differential Protection of Busbar	
<b>11</b>	<b>Current Transformer Selection, Operation &amp; Maintenance</b>	<b>42-44</b>
11.1	Selecting of Current Transformer	
11.2	Operating of Current Transformer	
<b>12</b>	<b>Communication</b>	<b>45-48</b>
12.1	PLCC	

12.2 SDH

12.3 Operation of SDH in Power System

12.4 STM (Synchronous Transport Module )

12.5 NMS (Network Management System)

12.6 SDH Testing

**13 Scada**

**49-54**

13.1 Why Scada

13.2 Modbus Protocol

**13 precautions regarding inspection & maintenance**

**55**

**14 references**



# Chapter 1

## INTRODUCTION

The Industrial Training program is an appreciable program designed to equip students to the real life working experience. It has been included in the curriculum of the Mumbai University in its new scheme. The theory and practical aspect is being joined together in the programme in order to find out how things are being done. This program has benefitted many students to gain the practical knowledge and on other topics synonymous to technical field.

On receiving the permission from the ADANI ELECTRICITY, 4 students from Anjuman - I - Islam's Kalsekar Technical Campus, Panvel, went for an Industrial training at ADANI ELECTRICITY at Powai. The training was of 6 months ( 1<sup>st</sup> Sept 2018 - 28<sup>th</sup> Feb 2019 ). The training will help students to gain increased maturity and understanding of the work place. The training has taught students, how to interact effectively with other workers and supervisors under various conditions in the organization. The training has exposed the students to work methods and techniques in handling equipment and machines that may not be available in the education institution.

### 1.1 Adani Power Limited :

**Adani Power Limited** is the power business subsidiary of Indian conglomerate Adani Group with head office at Ahmedabad, Gujarat. The company is India's largest private power producer, with capacity of 10,440 MW<sup>[1]</sup> and also it is the largest solar power producer of India with a capacity of 688 MW.<sup>[2]</sup> Adani Power Limited is ranked 334th in the top companies in India in Fortune India 500 list of 2011.<sup>[3]</sup>

The company operates five supercritical boilers of 660 MW each (as per March 2012) at Mundra, Gujarat & five 660 MW units (as per May 2015) at Tiroda, Maharashtra. It also operates a mega solar plant of 40 MW at Naliya, Bitta, Kutch, Gujarat.<sup>[4]</sup> It is India's first company to achieve the supercritical technology. The plant is the only thermal power plant in India to be certified by UN under CDM.<sup>[5]</sup>

The company is implementing 16,500 MW at different stages of construction. Its mission is to achieve 20,000 MW by 2020. 100 MW of solar power station is also under advanced stage of implementation at Surendranagar in Gujarat out of which 40 MW is already commissioned.<sup>[6]</sup> The company has gone to long term PPAs of about 7,200 MW of its 9,280 MW with government of Gujarat, Maharashtra, Haryana and Rajasthan.

### 1.2 History:

Adani Power was started as a power trading company in 1996. It started generation in July 2009 by implementation of its first 330 MW of 4,620 MW at Mundra. The Mundra super mega project is the largest coal-based power project of India and fifth largest in the world.

The company commissioned another three 330 MW by November 2010 and country's first supercritical unit of 660 MW on 22 December 2010, making its capacity 1,980 MW. On 6 June 2011 it synchronised its second unit of 660 MW bringing the total generating capacity to 2,640 MW and on 2 October 2011, it synchronised its third super critical unit with national grid. With this, Adani Power has become largest thermal power generating company in the private sector, and the Mundra plant has become India's largest power plant with capacity of 3,300 MW.

In February 2012, it commissioned the last unit of Mundra Project to take its capacity to 4,620 MW which makes the Mundra TPP to be the largest privately held thermal power plant in the world and fifth largest on an overall basis, as of March 2012. This plant became the largest thermal power plant in Asia after its completion.

On April 3, 2014, Adani Power Ltd. announced the commissioning of the fourth unit of 660 MW at its power plant at Tiroda in Maharashtra, thus emerging as the largest private power producer in India, with an overall installed capacity of 9,280 MW. The fifth unit was commissioned later in 2014.

Adani Power Ltd. announced the completion of acquisition of Udupi Power Corporation Limited on May 11, 2015. With this, Adani Power has a total commissioned capacity of 10,440 MW, making the company the largest private power producer in India.

### 1.3 Operations:

---

- Mundra Thermal Power Station. A **4,620 MW** (4x 330 MW, 5x 660 MW) coal-based thermal power plant at Mundra, Kutch district, Gujarat. It operates first power transmission project of 400 kV Double Circuit Transmission System from the Mundra plant to Dehgam (430 km)
- Kawai Thermal Power Station. A **1,320 MW** (2x 660 MW) coal-based thermal power plant at Kawai village, Baran district, Rajasthan. This plant is fully functional <sup>[8]</sup>
- Udupi Power Plant. A **1,200 MW** (2x 600 MW) coal-based thermal power plant at Padubidri, Udupi district, Karnataka. Both units are fully functional since September 2012. Adani Power acquired this power plant from Lanco Infratech in August 2014 for Rupees 6,000 crores.<sup>[9][10]</sup>
- Tirora Thermal Power Station. A **3,300 MW** (5x 660 MW) coal-based thermal power plant at Tirora, Gondia district, Maharashtra.
- Kamuthi Solar Power Project - A **648 MW** solar power station.<sup>[11]</sup>
- The company produces **40 MW** of solar power in Bitta, Kutch Gujarat.

#### 1.4 Future projects:

---

As of January 2011, the company has 16,500 MW<sup>[8]</sup> under implementation and planning stage. Included are a 3,300 MW coal based TPP at Bhadreswar in Gujarat, a 2,640 MW TPP at Dahej, Gujarat, a 1,320 MW TPP at Chhindwara in Madhya Pradesh, a 2,000 MW TPP at Anugul, Orissa, a 2,000 MW TPP at Sambalpur, Orissa, and a 2,000 MW gas-based power project at Mundra, Gujarat. The company is bidding for a 1,000 MW lignite coal-based power plant in Kosovo.<sup>[12]</sup>

In the second week of August 2014, Adani Power acquired Lanco Infratech's Udupi thermal power plant in a Rupee 6,000 crores deal. This would add another 1,200 MW installed capacity, taking the group capacity to 10,480 MW.<sup>[13]</sup> In November Adani Power (Jharkhand) has signed a long-term pact with Bangladesh Power Development Board to supply electricity from its upcoming 1,600 MW plant at Godda in Jharkhand.

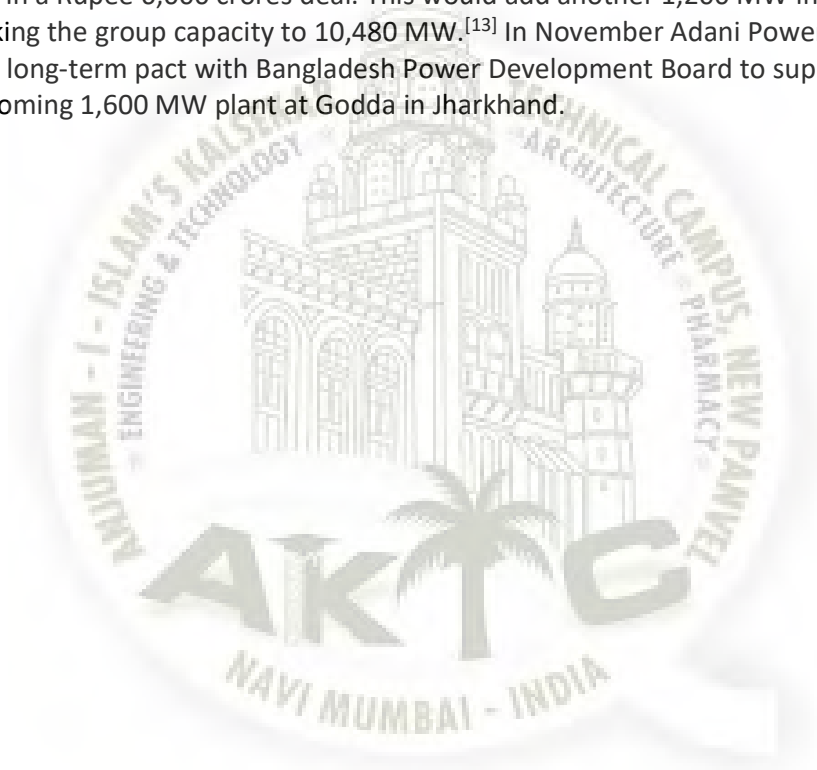

# Chapter 2

## Major Components in Electrical Substations and their Workings:

The power system is a constituent of power generation, transmission and distribution systems. For all the power system operations, substations are required for their course of action. Substations are congregation of electrical equipment through which consumers get supply of electrical power from generating stations. By varying the voltage levels or frequency or any other aspects, the required electrical quantity can be altered in substations to provide quality power to consumers.

Based on the application of substations, they are classified into different types: Generation substation, Indoor substation, Outdoor substation, Pole mounted substation, Switching substation, Transmission substation, Converter substation and Distribution substation. In rare cases like wind farm power generation system, multiple hydroelectric and thermal power plants one can observe the collector substation which is used for transferring power from multiple turbines into one transmission unit.

The substation is an assembly of the following major electrical equipments:

- Electrical Power transformers
- Instrument transformers
- Conductors & Insulators
- Isolators
- Bus bars
- Lightning arresters
- Circuit breakers
- Relays
- Capacitor banks and miscellaneous equipment

### 2.1 Electrical Power Transformer:

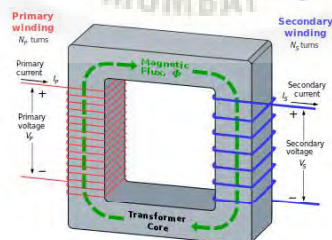

Electrical power transformer

A static electrical machine used for transforming power from one circuit to another circuit without changing frequency is termed as Power transformer. The transformers are generally used to step down or step up the voltage levels of a system for transmission and generation purpose. These transformers are classified into different types based on their design, utilization purpose, installation methods, and so on.

## 2.2 Instrument Transformers:

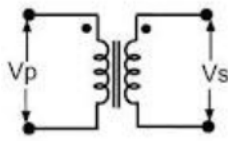

Symbol of VT

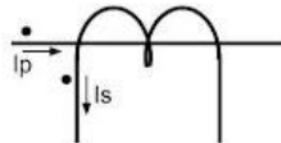

Symbol of CT

### Instrument transformers

The current and voltage transformers are together called as the Instrument transformers.

## 2.3 Current Transformer:

Current transformer is used for the measurement of the alternating current by taking samples of the higher currents of the system. These reduced samples are in accurate proportions with the actual high currents of the system. These are used for installation and maintenance of the current relays in substations for protection purpose which are normally have low-current ratings for their operation.

## 2.4 Potential Transformer:

Potential transformer is quite similar to the current transformer, but it is used for taking samples of high voltages of a system for providing low-voltage to the relays of protection system and also to the low-rating meters for voltage measurement. From this low-voltage measurement, the actual system's high voltage can be calculated without measuring high voltages directly to avoid the cost of the measurement system.

## 2.5 Conductors:

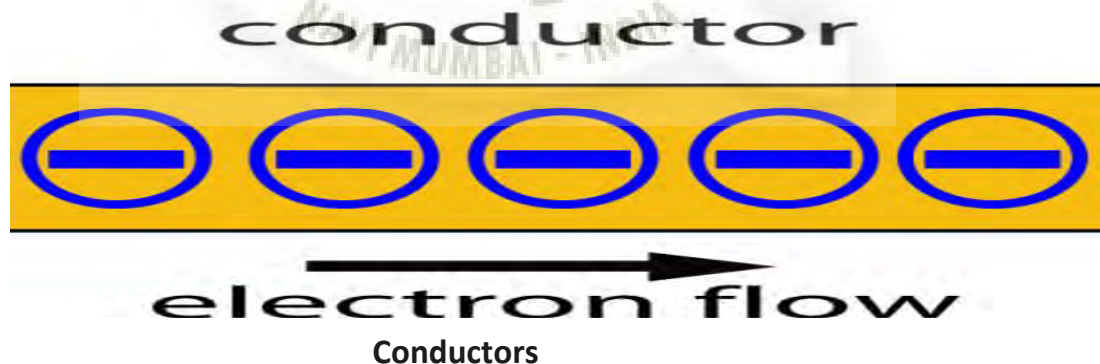

The material or object that obeys the electrical property conductance (mostly made of metals such as aluminum and copper) and that allows the flow of electric charge is called conductor. Conductors permit free movement of the flow of electrons through them. These are used for the transmission of power or electrical energy from one place (generating station) to another place (consumer point where power is consumed by the loads) through substations.

Conductors are of different types and mostly aluminum conductors are preferred in practical power systems.

## 2.6 Insulators:



Insulators

The material which does not allow free movement of electrons or electric charge is called as an insulator. Hence, insulators resist electricity with their high resisting property. There are different types of insulators such as suspension type, strain type, shackle, pin type and so on. A few types of insulators are shown in the above figure. Insulators are used for insulation purpose while erecting electric poles with conductors to avoid short circuit and for other insulation requirements.



## 2.7 Isolators:

11 KV ISOLATORS

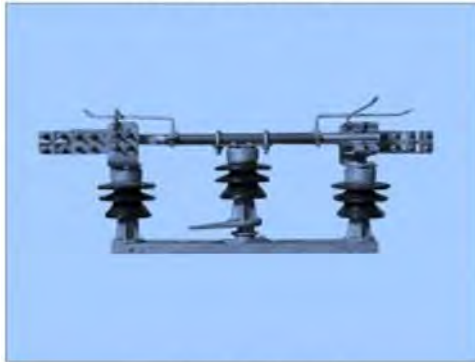

33 KV ISOLATORS



Isolators

Isolator is a manually operated electrical switch that isolates the faulty section or the section of a conductor or a part of a circuit of substation meant for repair from a healthy section in order to avoid occurrence of more severe faults. Hence, it is also called as a disconnect or disconnecting switch. There are different types of isolators used for different applications such as single-break isolator, double-break isolator, bus isolator, line isolator, etc.

## 2.8 Bus Bars:

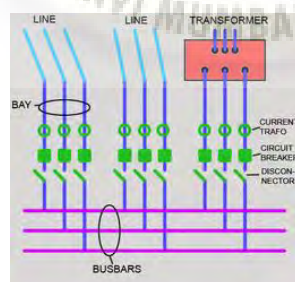

Bus bars

The conductor carrying current and having multiple numbers of incoming and outgoing line connections can be called as bus bar, which is commonly used in substations. These are classified into different types like single bus, double bus and ring bus.

## 2.9 Lightning Arresters:



Lightning Arresters

The substation equipments such as conductors, transformers, etc., are always erected outdoor. Whenever light surges occur then, a high-voltage pass through these electrical components causing damage to them (either temporary or permanent damage based on the amount of voltage surge). Therefore, to avoid this difficulty, lightning arresters are placed to pass the entire lightning surges to earth. There are other arresters which are used to ground the switching surges called as surge arresters.

## 2.10 Circuit Breakers:



Circuit Breakers

For the protection of substation and its components from the over currents or over load due to short circuit or any other fault the faulty section is disconnected from the healthy section

either manually or automatically. If once the fault is rectified, then again the original circuit can be rebuilt by manually or automatically. Different types of circuit breakers are designed based on different criteria and usage. But in general mostly used circuit breakers are Oil circuit breaker, Air circuit breaker, SF6 circuit breaker, Vacuum Circuit Breaker, and so on.

## 2.11 Relays:

### Relay Basics

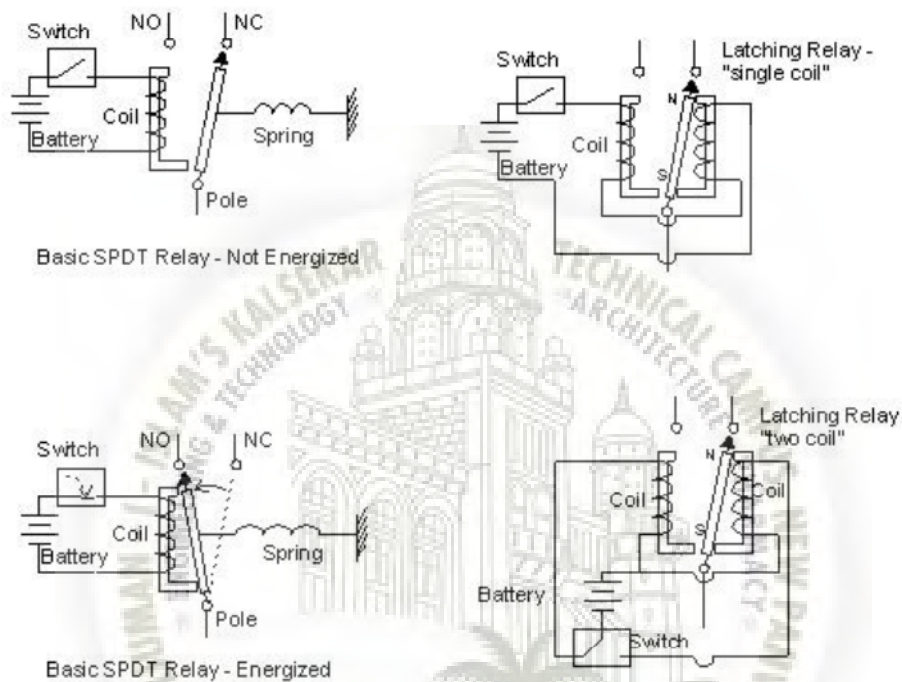

### Relays

Relays are used for disconnecting the circuits by manual or automatic operation. Relay consists of the coil which is excited or energized and such that making the contacts of relay closed activates the relay to break or make the circuit connection. There are different types of relays such as over current relays, definite time over current relays, voltage relays, auxiliary relays, reclosing relays, solid state relays, directional relays, inverse time over current relays, microcontroller relays, etc. The above figure shows some basic relays and their operation.

## 2.12 Capacitor banks:

A Capacitor bank is a set of many identical capacitors connected in series or parallel within an enclosure and is used for the power factor correction and basic protection of substation. These capacitor banks act as a source of reactive power, and thus, the phase difference between voltage and current can be reduced by the capacitor banks. They will increase the ripple current capacity of the supply. It avoids undesirable characteristics in the

power system. It is the most economical method for maintaining power factor and of correction of the power lag problems.



**Capacitor banks**

Emerging trends in technological development have created advancement in the substation installation and maintenance. For example, SCADA, supervisory control and data acquisition technique made it possible to control a substation automatically from a remote location. For more data regarding miscellaneous components and technologies in substations, post your queries in the comments section below.

# Chapter 3

## Define electrical maintenance:

The technical **meaning of maintenance** involves functional checks, servicing, repairing or replacing of necessary devices, **equipment**, machinery, building infrastructure, and supporting utilities in industrial, business, governmental, and residential installations. An electrical maintenance engineer is responsible for planning the maintenance to ensure the smooth running of production lines in a company.

### 3.1 Types of Maintenance :

#### 3.2.1 Types:

---

The basic types of maintenance falling under MRO include:

- Preventive or scheduled maintenance, where equipment or facilities are inspected, maintained and protected before break down or other problems occur.
- Corrective maintenance where equipment is repaired or replaced after wear, malfunction or break down.
- Predictive maintenance, which uses sensor data to monitor a system, then continuously evaluates it against historical trends to predict failure before it occurs.
- Architectural conservation employs MRO to preserve, rehabilitate, restore, or reconstruct historical structures with stone, brick, glass, metal, and wood which match the original constituent materials where possible, or with suitable polymer technologies when not.<sup>[11]</sup>

#### 3.2.2 Preventive:

Preventive maintenance is maintenance performed with the intent of avoiding failures, safety violations, unnecessary production costs and losses, and to conserve original materials of fabrication. The effectiveness of a preventive maintenance schedule depends on the RCM analysis which it was based on, and the ground rules used for cost efficacy.

#### 3.2.3 Corrective :

Corrective maintenance is a type of maintenance used for equipment after equipment break down or malfunction is often most expensive – not only can worn equipment damage other parts and cause multiple damage, but consequential repair and replacement costs and loss of revenues due to down time during overhaul can be significant. Rebuilding and resurfacing of equipment and infrastructure damaged by erosion and corrosion as part of corrective or preventive maintenance programmes involves conventional processes such as welding and metal flame spraying, as well as engineered solutions with thermoset polymeric materials.

### 3.2.4 Predictive:

More recently, advances in sensing and computing technology have given rise to *predictive maintenance*. This maintenance strategy uses sensors to monitor key parameters within a machine or system, and uses this data in conjunction with analysed historical trends to continuously evaluate the system health and predict a breakdown before it happens. This strategy allows maintenance to be performed more efficiently, since more up-to-date data is obtained about how close the product is to failure.

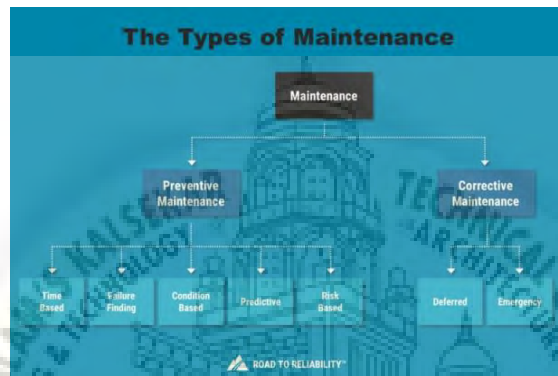

(1)



(2)

# Chapter 4

## Maintenance of Transformers:

A power transformer is most costly and essential equipment of an electrical transformer. So for getting high performance and long functional life of the transformer, it is desired to perform various maintenance activities. Not only that, a power transformer also requires various maintenance actions including measurement and testing of different parameters of the transformer. There are mainly two types of **maintenance of transformer**. We perform one group is in routine basis, and second group is as when required. That means for getting smooth performance from a transformer we have to perform some maintenance actions in regular basis.

Some other type of **maintenance of transformer** we perform as when they are required. But if one performs regular maintenance properly, he may not have any provision of performing emergency maintenance. The regular checking and maintenance of transformer is also known as condition maintenance. Hence by proper condition maintenance one can avoid emergency and breakdown maintenance. That is why one technical personnel should mainly concentrate on condition maintenance. As 100% condition maintenance causes 0% breakdown of an equipment.

There are many different maintenance action, to be performed on a power transformer. Some of them in yearly basis, some of them are monthly basis, some other are quarterly, some are half-yearly basis. These are mainly transformer maintenance action, which to be performed in 3 to 4 years interval.



#### 4.1 Daily Basis Maintenance and Checking:

There are three main things which to be checked on a power transformer in daily basis and they are :

1. Reading of MOG (Magnetic Oil Gage) of main tank and conservator tank.
2. Color of silica gel in breather.
3. Leakage of oil from any point of a transformer.

In case of unsatisfactory oil level in the MOG, oil to be filled in transformer and also the transformer tank to be checked for oil leakage. If oil leakage is found take required action to plug the leakage. If silica gel becomes pinkish, it should be replaced.

#### 4.2 Monthly Basis Maintenance of Transformer:

Let us first discuss about the action to be taken on power transformer in monthly basis.

1. The oil level in oil cap under silica gel breather must be checked in one month interval. If it is found the transformer oil inside the cup comes below the specified level, oil to be top up as per specified level.
2. Breathing holes in silica gel breather should also be checked monthly and properly cleaned if required, for proper breathing action.
3. If the transformer has oil filled bushing the oil level of transformer oil inside the bushing must be visually checked in the oil gage attached to those bushing. This action also to be done monthly basis.  
If it is required, the oil to be filled in the bushing upto correct level. Oil filling to be done under shutdown condition.

#### 4.3 Maintenance of Transformer on Half Yearly Basis:

The transformer oil must be checked half yearly basis that means once in 6 months, for dielectric strength, water content, acidity, sludge content, flash point, DDA, IFT, resistivity for transformer oil.

In case of distribution transformer, as they are operating light load condition all the time of day remaining peak hours, so there are no maintenance required.

#### 4.4 Yearly Basis Transformer Maintenance Schedule:

1. The auto, remote, manual function of cooling system that means, oil pumps, air fans, and other items engaged in cooling system of transformer, along with their control circuit to be checked in the interval of one year. In the case of trouble, investigate control circuit and physical condition of pumps and fans.
2. All the bushings of the transformer to be cleaned by soft cotton cloths yearly. During cleaning the bushing should be checked for cracking.
3. Oil condition of OLTC to be examined in every year. For that, oil sample to be taken from drain valve of divertor tank, and this collected oil sample to be tested for dielectric strength (BDV) and moisture content (PPM). If BDV is low and PPM for moisture is found high compared to recommended values, the oil inside the OLTC to be replaced or filtered.



4. Mechanical inspection of Buchholz relays to be carried out on yearly basis.
5. All marshalling boxes to be cleaned from inside at least once in a year. All illumination, space heaters, to be checked whether they are functioning properly or not. If not, required maintenance action to be taken. All the terminal connections of control and relay wiring to be checked and tighten at least once in a year.
6. All the relays, alarms and control switches along with their circuit, in R&C panel (Relay and Control Panel) and RTCC (Remote Tap Changer Control Panel) to be cleaned by appropriate cleaning agent.
7. The pockets for OTI, WTI (Oil Temperature Indicator & Winding Temperature Indicator) on the transformer top cover to be checked and if required oil to be replenished.
8. The proper function of Pressure Release Device and Buchholz relay must be checked annually. For that, trip contacts and alarm contacts of the said devices are shorted by a small piece of wire, and observe whether the concerned relays in remote panel are properly working or not.
9. Insulation resistance and polarization index of transformer must be checked with battery operated megger of 5 KV range.
10. Resistive value of earth connection and rizer must be measured annually with clamp on earth resistance meter.
11. DGA or Dissolve Gas Analysis of transformer Oil should be performed, annually for 132 KV transformer, once in 2 years for the transformer below 132 KV transformer and in 2 years interval for the transformer above 132 KV transformer.

#### **4.5 The Action to be taken once in 2 years :**

- 1.The calibration of OTI and WTI must be carried once in two years.
- 2.Tan & delta; measurement of bushings of transformer also to be done once in two years.

# Chapter 5

## Maintenance of Current Transformer:

A Current Transformer or CT is very essential equipment installed in an electrical substation for electrical measurement and protection purpose. If a current transformer does not perform properly, there may be huge disturbance in the system due to malfunctioning of protection relays. So far accurate measurement and smooth operation of electrical power system, CTs must be properly maintained. A schedule of such maintenance of current transformer is preferred below for ready reference. Let us first discuss about the maintenance of CT which to be performed in one year interval.

1. Insulation resistance of the CT must be checked in yearly basis. During insulation resistance measurement, it must be remembered that, in current transformer there are two level of insulation. The insulation level of primary of CT is quite high as it has to withstand full system voltage. But the secondary of the CT has low insulation level generally 1.1 KV. So primary to secondary and primary to earth of a current transformer are measured with 2.5 or 5 KV megger.
2. Thermo vision scanning of primary terminals and top dome of a live CT should be performed at least once in a year. This scanning can be done with help of infra-red Thermo-vision Camera.
3. All the CT secondary connections in CT secondary box and CT junction box must be checked, cleaned and tighten every year to ensure maximum possible low resistance path for CT secondary currents. It should also be ensured that CT junction box is properly cleaned.

There are some other maintenance of Current Transformer which to be performed in half yearly basis, such as,

1. The porcelain housing of CTs should be checked for hire crack if any crack is observed on insulator, necessary advice to be obtained from manufacturer.
2. The porcelain insulator housing of current transformer, to be cleaned properly by cotton clothes.

Now we will discuss about monthly basis maintenance of current transformer.

1. Oil leakage from any joint should be visually inspected if leakage found, it must be plugged by taking shutdown.
2. The secondary terminals are also checked for oil leakage, if leakage found, immediate action to be taken to plug the leakage.

In addition to these, tans or loss factor measurement to be performed on a current transformer, preferably above 66 KV class, once in two years. Dissolve Gas Analysis of oil also to be done preferably once in 4 years. If the results are found unsatisfactory as per standard, the insulating oil must be replaced.

# Chapter 6

## Maintenance of Voltage Transformer and Capacitor Voltage Transformer:

Construction wise a voltage transformer and a capacitor voltage transformer are same. Hence basis scheme of maintenance of both voltage transformer and capacitor voltage transformer are more or less same. As heavy current does not flow through PT and CVT, the defect and fault generally very low.

That is why monthly maintenance of voltage transformer and maintenance of capacitor voltage transformer may not be required. Moreover very frequent maintenance of bus PT or CVT may not also be possible as far taking shutdown of such PT or CVT total bus section would be out of protection and metering. Only yearly maintenance of such equipments are sufficient.

### 6.1 Yearly Maintenance of Voltage Transformer or Capacitor Voltage Transformer:

1. The porcelain housing must be cleaned with cotton clothes.
2. The spark gap assembly to be checked on yearly basis. Remove the moveable part of spark gap as assembly, clean the braes electrode with emery paper and fix it back in position.
3. The high frequency earthing point should be visually checked yearly in the case, the point is not used for PLCC.
4. Thermo vision camera to be used for checking any hot spots in the capacitor stacks to ensure pro action of rectification.
5. The terminal connections PT junction box including earth connections to be checked for tightness once in a year. In addition to that, the PT junction box also to be cleaned properly once in a year.
6. The health of all gasket joint also to be visually checked and replaced if any damaged gasket found.

# Chapter 7

## Circuit Breaker Maintenance:

For *maintenance of circuit breaker* or *circuit breaker maintenance*, it must be first switched off and then isolated from both sides by opening concerned electrical isolator. At this no isolated condition the circuit breaker must be operated for local and remote condition yearly and when required. The circuit breaker should be operated electrically from local and remote then mechanically from local. This type of operation makes the breaker more reliable by removing any coating developed between sliding surfaces.

### 7.1 Bulk Oil Circuit Breaker Maintenance:

For bulk oil circuit breaker, we should check contact burning. If burning is very light, remove the burn beads and polish the surface. If burning is quite heavy, replace the tips and arcing ring by new set. We should loose and tight the tips few times before final tightening is done. In addition to that we should also check the extinguishing chamber. It must be removed from the breaker unit and after washing the chamber by insulating oil it is kept as upside down. If the condition of any part indicates severe burning, we should dismantle the chamber and replace the burned/damaged parts.

Next point is cleaning and lubricating CB mechanism. The rust on the mechanism and also from metal mechanism box surface should be removed by non fluffy cotton cloths. The mechanism including gear wheel should be lubricated by high grade grease. But it should be remembered that the friction clutch must be lubricated. In case of minimum oil circuit breaker MOCB, insulator must be cleaned and carbon deposition if any should be removed by Trichloro Ethylene or Acetone. The manual provided by manufacturer for greasing and lubricating should also be followed beside this general instruction.

The locking pins of tie rods should be checked half yearly. All the foundation bolts electrical terminal connections at CB power circuit must be tighten properly after removing oxide coating if nay. This must be done half yearly. The proper adjustment of auxiliary switch by ensuring correct NO NC contacts at breaker OFF and ON condition must be checked half yearly and in addition to that the auxiliary switch's contacts should be cleaned properly with help of hard brushes. The spring charging motor and mechanism should also be cleaned and associated bearing should also be lubricated half yearly.

### 7.2 Minimum Oil Circuit Breaker Maintenance:

In case of MOCB, the breaker should be checked monthly for oil leakage and oil level. If oil leakage is found it must be attended and for low oil level top up oil up to desire level. Visual inspection of circuit breaker and its operating mechanism along with quality of painting, mechanism kiosk door gasket should be carried out quarterly if any damaged found take proper action.

The oil dash pot in operating mechanism must be checked for oil leakage quarterly if leakage is found, replace the defective and damaged O – rings. It is also highly recommended to ensure the prescribed duty cycle of operation of the breaker including reclosing annually.

### **7.3 Maintenance of Air Blast Circuit Breaker:**

For air blast circuit breaker there are some special cares to be taken in addition to general instruction for maintenance of operating mechanism. Actually for operating mechanisms and for other some features the maintenance processes and schedules are same for all oil circuit breaker, air circuit breaker, SF<sub>6</sub> circuit breaker and vacuum circuit breaker.

In air circuit breaker, the air leakage should be checked as and when it is required. If leakage is found, plug the leakage.

The grading capacitors must be checked for oil leakage monthly. If leakage found plug it. Yearly, dew point of the operating air at the outlet of the air dryer should be measured with the help of Dew Point Meter or Hygro Meters.

### **7.4 SF<sub>6</sub> Circuit Breaker Maintenance:**

As we said earlier for operating mechanisms and for some other features the maintenance processes and schedules are same for all oil circuit breaker, air circuit breaker, SF<sub>6</sub> circuit breaker and vacuum circuit breaker.

In addition to that in SF<sub>6</sub> CB some extra care to be taken.

SF<sub>6</sub> circuit breaker must be checked for SF<sub>6</sub> gas leakage, if unwanted SF<sub>6</sub> low gas pressure alarm comes. This is efficiently done by gas leakage detector.

If the circuit breaker is provided with gradient capacitors, these must be checked for oil leakage monthly. If leakage found plug it.

Dew point of SF<sub>6</sub> should be checked with the help of dew point meter or hygro meters in every 3 to 4 years interval.

Maintenance of Vacuum Circuit Breaker

In case of vacuum circuit breaker there is nothing special all the processes and schedules are same as in case of other circuit breaker.

# Chapter 8

## Maintenance of relays:

The relay is one of the most dependable electromechanical devices in use, but like any other mechanical or electrical device, relays occasionally wear out or become inoperative. Should an inspection determine that a relay is defective, the relay should be removed immediately and replaced with another of the same type. You should be sure to obtain the same type relay as a replacement. Relays are rated in the same type. You should be sure to obtain the same type relay as a replacement. Relays are rated in voltage, amperage, type of service, number of contacts, and similar characteristics.

Relay coils usually consist of a single coil. If a relay fails to operate, the coil should be tested for open circuit, short circuit, or short to ground. An open coil is a common cause of relay failure.

During preventive maintenance you should check for charred or burned insulation on the relay and for darkened or charred terminal leads. Both of these indicate overheating, and the likelihood of relay breakdown. One possible cause for overheating is that the power terminal connectors are not tight. This would allow arcing at the connection.

The build-up of film on the contact surfaces of a relay is another cause of relay trouble. Although film will form on the contacts by the action of atmospheric and other gases, grease film is responsible for a lot of contact trouble. Carbon build-up which is caused by the burning of a grease film or other substance (during arcing), also can be troublesome. Carbon forms rings on the contact surfaces and as the carbon rings build-up, the relay contacts are held open.

When current flows in one direction through a relay, a problem called "cone and crater" may be created at the contacts. The crater is formed by transfer of metal from one contact to the other contact, the deposit being in the shape of a cone. This condition is shown in figure 3-25(A).

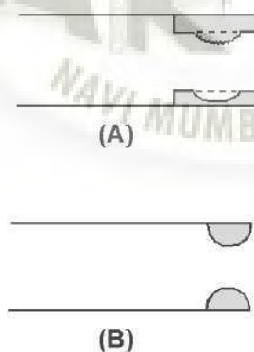
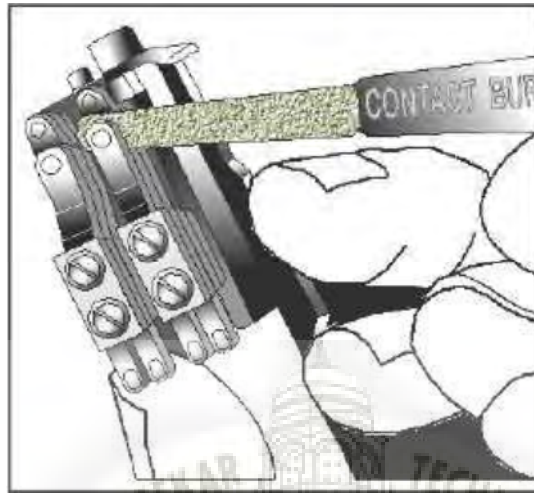

Figure 3-25.—Relay contacts.

Some relays are equipped with ball-shaped contacts and, in many applications, this type of contact is considered superior to a flat surface. Figure 3-25(B) shows a set of ball-shaped contacts. Dust or other substances are not as readily deposited on a ball-shaped surface. In addition, a ball-shaped contact penetrates film more easily than a flat contact. When you clean or service ball-shaped relay contacts, be careful to avoid flattening or otherwise

altering the rounded surfaces of the contacts, YOU could damage a relay if you used sandpaper or emery cloth to clean the contacts. Only a burnishing tool, shown in figure 3-26 should be used for this purpose.



**Figure 3-26.—Burnishing tool.**

You should not touch the surfaces of the burnishing tool that are used to clean the relay contacts. After the burnishing, tool is used, it should be cleaned with alcohol. Contact clearances or gap settings must be maintained in accordance with the operational specifications of the relay. When a relay has bent contacts, you should use a point bender (shown in figure 3-27) to straighten the contacts. The use of any other tool could cause further damage and the entire relay would have to be replaced.



**Figure 3-27.—Point bender.**

A **POINT BENDER** is used to adjust contact spacing of a relay. No other tool should be used.

Cleanliness must be emphasized in the removal and replacement of covers on semi sealed relays. The entry of dust or other foreign material can cause poor contact connection. When the relay is installed in a position where there is a possibility of contact with explosive fumes, extra care should be taken with the cover gasket. Any damage to, or incorrect seating of the gasket increases the possibility of igniting the

# Chapter 9

## Electrical Isolator or Electrical Isolation Switch:

### 9.1 Definition of Isolator:



Circuit breaker always trip the circuit but open contacts of breaker cannot be visible physically from outside of the breaker, and that is why it is recommended not to touch any electrical circuit just by switching off the circuit breaker. So for better safety, there must be some arrangement so that one can see the open condition of the section of the circuit before touching it. The isolator is a mechanical switch which isolates a part of the circuit from the system as when required. **Electrical isolators** separate a part of the system from rest for safe maintenance works. So the definition of isolator can be rewritten as an isolator is a manually operated mechanical switch which separates a part of the electrical power. Isolators are used to open a circuit under no load. Its main purpose is to isolate one portion of the circuit from the other and is not intended to be opened while current is flowing in the line. Isolators are generally used on both ends of the breaker so that repair or replacement of circuit breaker can be done without any danger.



## 9.2 Types of Electrical Isolators:

There are different types of isolators available depending upon system requirement such as

1. Double Break Isolator
2. Single Break Isolator
3. Pantograph type Isolator.

Depending upon the position in the power system, the isolators can be categorized as

1. Bus side isolator – the isolator is directly connected with main bus
2. Line side isolator – the isolator is situated at line side of any feeder
3. Transfer bus side isolator – the isolator is directly connected with transfer bus.

## 9.3 Constructional Features of Double Break Isolators:



Let's discuss constructional features of Double Break Isolators. These have three stacks of post insulators as shown in the figure. The central post insulator carries a tubular or flat male contact which can be rotated horizontally with a rotation of central post insulator. This rod type contact is also called moving contact.

The female type contacts are fixed on the top of the other post insulators which fitted at both sides of the central post insulator. The female contacts are generally in the form of spring-loaded figure contacts. The rotational movement of male contact causes to come itself into female contacts and isolators becomes closed. The rotation of male contact in the opposite direction make to it out from female contacts and isolators becomes open.

Rotation of the central post insulator is done by a driving lever mechanism at the base of the post insulator, and it is connected to operating handle (in case of hand operation) or motor (in case of motorized operation) of the isolator through a mechanical tie rod.

#### 9.4 Constructional features of Single Break Isolators:

The contact arm is divided into two parts one carries male contact and other carries female contact. The contact arm moves due to rotation of the post insulator upon which the contact arms are fitted. Rotation of both post insulators stacks in opposite to each other causes to close the isolator by closing the contact arm. Counter rotation of both post insulators stacks open the contact arm and isolator becomes in off condition. This motorized form of this type of isolators is generally used, but an emergency hand driven mechanism is also provided.



#### 9.5 Earthing Switches:

Earthing switches are mounted on the base of line side isolator. Earthing switches are usually vertically broken switches. Earthing arms (contact arm of earthing switch) usually are aligned horizontally at off condition during switching on the operation, these earthing arms rotate and move to vertical position and make contact with earth female contacts fitted at the top of the post insulator stack of the isolator at its outgoing side. The earthing arms are so interlocked with the main isolator moving contacts that it can be closed only when the primary contacts of the isolator are in open position. Similarly, the main isolator contacts can be closed only when the earthing arms are in open position.

#### 9.6 Operation of Electrical Isolator:

As no arc quenching technique is provided in isolator it must be operated when there is no chance current flowing through the circuit. No live circuit should be closed or open by isolator operation. A complete live closed circuit must not be opened by isolator operation, and also a live circuit must not be closed and completed by isolator operation to avoid huge arcing in between isolator contacts. That is why isolators must be open after circuit breaker is open, and these must be closed before circuit breaker is closed. The isolator can be operated by hand locally as well as by motorized mechanism from a remote position. Motorized operation arrangement costs more compared to hand operation.

# Chapter 10

## Busbar Protection | Busbar Differential Protection Scheme :

In early days only conventional over current relays were used for **busbar protection**. But it is desired that fault in any feeder or transformer connected to the busbar should not disturb busbar system. In viewing of this time setting of busbar protection relays are made lengthy. So when faults occurs on busbar itself, it takes much time to isolate the bus from source which may came much damage in the bus system.

In recent days, the second zone distance protection relays on incoming feeder, with operating time of 0.3 to 0.5 seconds have been applied for **busbar protection**.

But this scheme has also a main disadvantage. This scheme of protection can not discriminate the faulty section of the busbar.

Now days, electrical power system deals with huge amount of power. Hence any interruption in total bus system causes big loss to the company. So it becomes essential to isolate only faulty section of busbar during bus fault.

Another drawback of second zone distance protection scheme is that, sometime the clearing time is not short enough to ensure the system stability.

To overcome the above mentioned difficulties, differential busbar protection scheme with an operating time less than 0.1 sec., is commonly applied to many SHT bus systems.

### Differential Busbar Protection:

#### 10.1 Current Differential Protection:

The scheme of **busbar protection**, involves, Kirchoff's current law, which states that, total current entering an electrical node is exactly equal to total current leaving the node.

Hence, total current entering into a bus section is equal to total current leaving the bus section.

The principle of differential busbar protection is very simple. Here, secondaries of CTs are connected parallel. That means,  $S_1$  terminals of all CTs connected together and forms a bus wire. Similarly  $S_2$  terminals of all CTs connected together to form another bus wire.

A tripping relay is connected across these two bus wires.

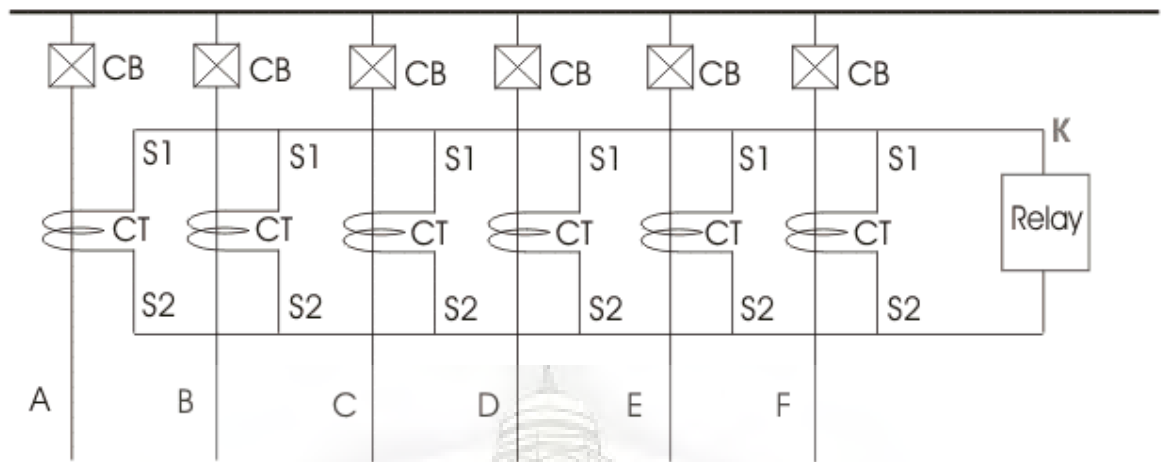

Here, in the figure above we assume that at normal condition feed, A, B, C, D, E and F carries current  $I_A$ ,  $I_B$ ,  $I_C$ ,  $I_D$ ,  $I_E$  and  $I_F$ .

Now, according to Kirchoff's current law,

$$I_A + I_B + I_C + I_D + I_E + I_F = 0$$

Essentially all the CTs used for differential busbar protection are of same current ratio.

Hence, the summation of all secondary currents must also be equal to zero.

Now, say current through the relay connected in parallel with all CT secondaries, is  $i_R$ , and  $i_A$ ,  $i_B$ ,  $i_C$ ,  $i_D$ ,  $i_E$  and  $i_F$  are secondary currents.

Now, let us apply KCL at node X. As per KCL at node X,

$$i_R + i_A + i_B + i_C + i_D + i_E + i_F = 0$$

$$\Rightarrow i_R + (i_A + i_B + i_C + i_D + i_E + i_F) = 0$$

$$\Rightarrow i_R + (\text{Sum of all secondary currents}) = 0$$

$$\Rightarrow i_R + 0 = 0 \text{ [ As sum of all secondary currents is zero ]}$$

So, it is clear that under normal condition there is no current flows through the **busbar protection** tripping relay. This relay is generally referred as Relay 87. Now, say fault is occurred at any of the feeders, outside the protected zone. In that case, the faulty current will pass through primary of the CT of that feeder. This fault current is contributed by all other feeders connected to the bus. So, contributed part of fault current flows through the corresponding CT of respective feeder. Hence at that faulty condition, if we apply KCL at node K, we will still get,  $i_R = 0$ .

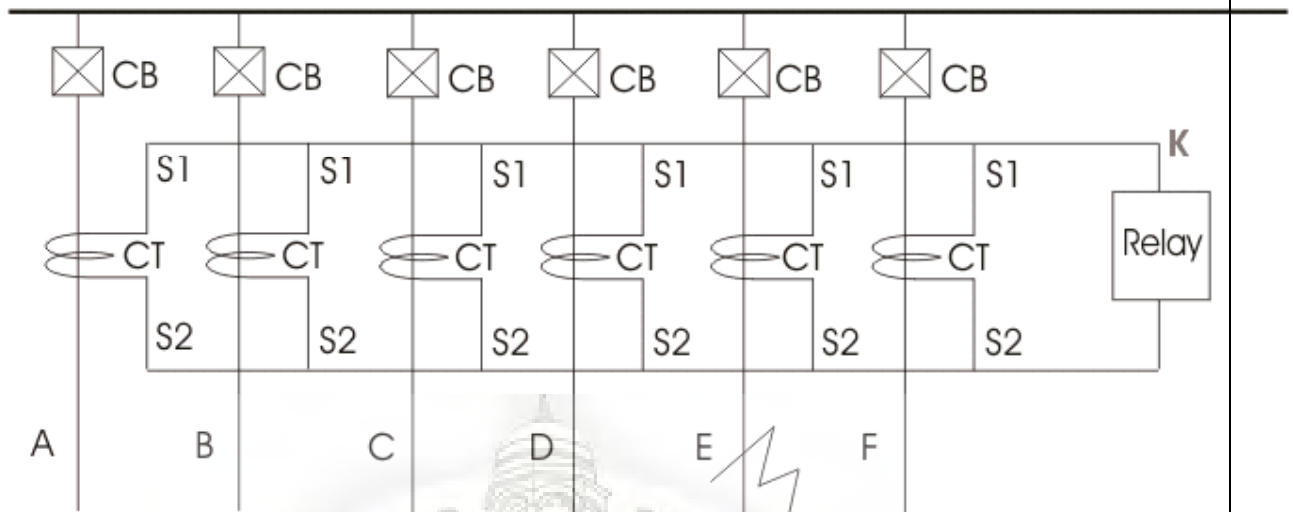

That means, at external faulty condition, there is no current flows through relay 87. Now consider a situation when fault is occurred on the bus itself. At this condition, also the faulty current is contributed by all feeders connected to the bus. Hence, at this condition, sum of all contributed fault current is equal to total faulty current. Now, at faulty path there is no CT. (in external fault, both fault current and contributed current to the fault by different feeder get CT in their path of flowing).

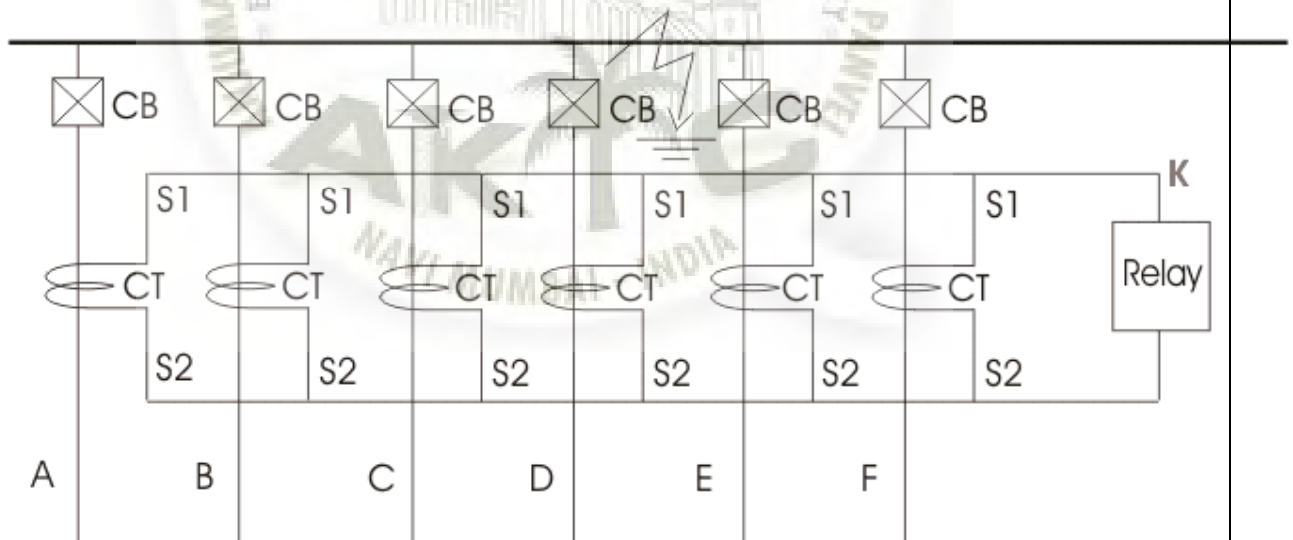

The sum of all secondary currents is no longer zero. It is equal to secondary equivalent of faulty current.

Now, if we apply KCL at the nodes, we will get a non zero value of  $i_R$ .

So at this condition current starts flowing through 87 relay and it makes trip the circuit breaker corresponding to all the feeders connected to this section of the busbar.

As all the incoming and outgoing feeders, connected to this section of bus are tripped, the bus becomes dead.

This differential busbar protection scheme is also referred as current differential protection of busbar.

## 10.2 Differential Protection of Sectionalized Bus:

During explaining working principle of current differential protection of busbar, we have shown a simple non sectionalized busbar. But in moderate high voltage system electrical bus sectionalized in than one sections to increase stability of the system. It is done because, fault in one section of bus should not disturb other section of the system. Hence during bus fault, total bus would be interrupted.

Let us draw and discuss about protection of busbar with two sections.

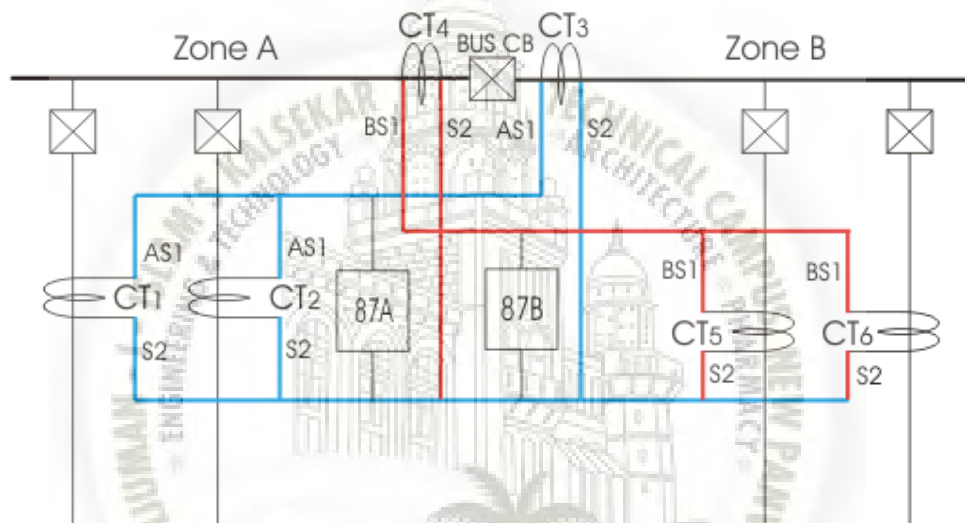

Here, bus section A or zone A is bounded by CT<sub>1</sub>, CT<sub>2</sub> and CT<sub>3</sub> where CT<sub>1</sub> and CT<sub>2</sub> are feeder CTs and CT<sub>3</sub> is bus CT.

Similarly bus section B or zone B is bounded by CT<sub>4</sub>, CT<sub>5</sub> and CT<sub>6</sub> where CT<sub>4</sub> is bus CT, CT<sub>5</sub> and CT<sub>6</sub> are feeder CT.

Therefore, zone A and B are overlapped to ensure that, there is no zone left behind this **busbar protection** scheme.

ASI terminals of CT<sub>1</sub>, 2 and 3 are connected together to form secondary bus ASI;

BSI terminals of CT<sub>4</sub>, 5 and 6 are connected together to form secondary bus BSI.

S<sub>2</sub> terminals of all CTs are connected together to form a common bus S<sub>2</sub>.

Now, busbar protection relay 87A for zone A is connected across bus ASI and S<sub>2</sub>.

Relay 87B for zone B is connected across bus BSI and S<sub>2</sub>.

This section **busbar differential protection scheme** operates in some manner simple current differential protection of busbar.

That is, any fault in zone A, with trip only CB<sub>1</sub>, CB<sub>2</sub> and bus C<sub>B</sub>.

Any fault in zone B, will trip only CB<sub>5</sub>, CB<sub>6</sub> and bus C<sub>B</sub>.

Hence, fault in any section of bus will isolate only that portion from live system.

In current differential protection of busbar, if CT secondary circuits, or bus wires is open the relay may be operated to isolate the bus from live system. But this is not desirable.

### 10.3 DC Circuit of Differential Busbar Protection:

A typical DC circuit for **busbar differential protection scheme** is given below.

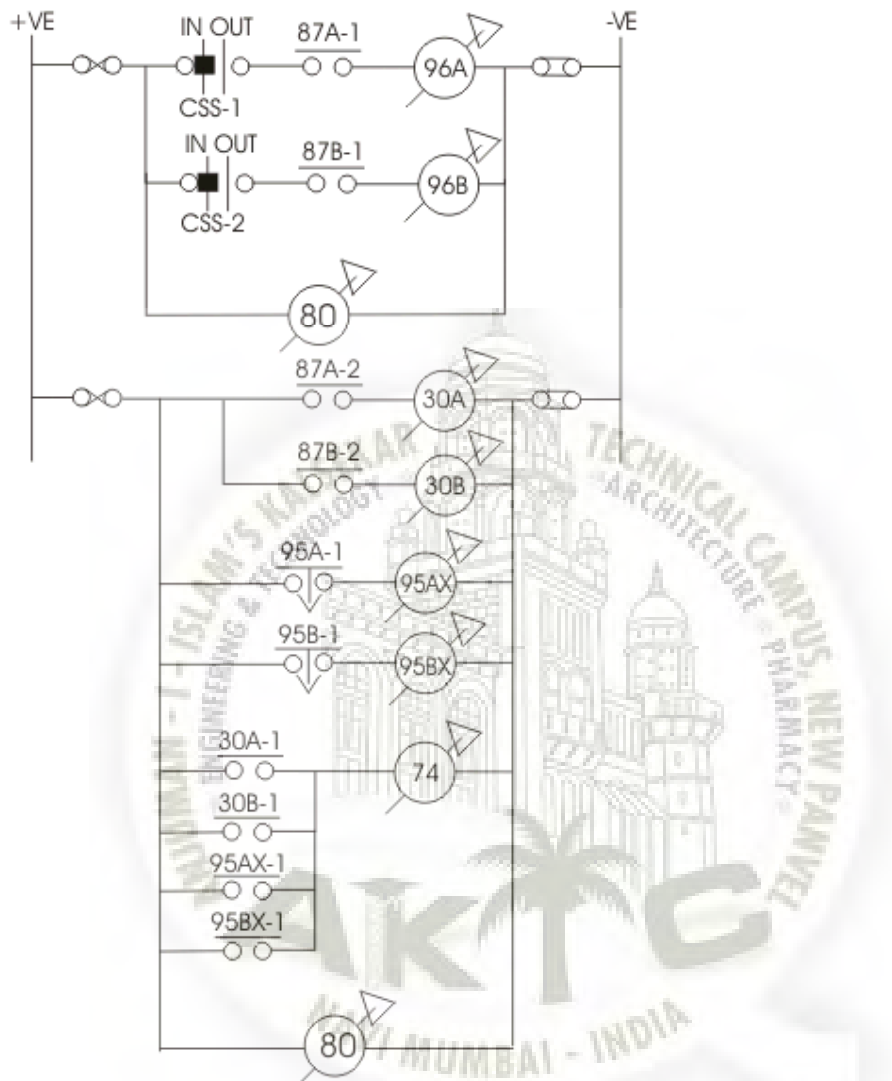

Here, CSSA and CSSB are two selector switch which are used to put into service, the **busbar protection** system for zone A and zone B respectively.

If CSSA is in "IN" position, protection scheme for zone A is in service.

If CSSB is in "IN" position, protection for zone B is in service.

Generally both of the switches are in "IN" position in normal operating condition. Here, relay coil of 96A and 96B are in series with differential busbar protection relay contact 87A-1 and 87B-1 respectively.

96A relay is multi contacts relay. Each circuit breaker in zone A is connected with individual contact of 96A.

Similarly, 96B is multi contacts relay and each circuit breaker in zone-B is connected with individual contacts of 96B.

Although here we use only one tripping relay per protected zone, but this is better to use





The secondaries of all CTs and differential relay form a closed loop. If polarity of all CTs are properly matched, the sum of voltage across all CT secondaries is zero. Hence there would be no resultant voltage appears across the differential relay. When a buss fault occurs, sum of the all CT secondary voltage is no longer zero. Hence, there would be current circulate in the loop due to the resultant voltage. As this loop current also flows through the differential relay, the relay is operated to trip all the circuit beaker associated with protected bus zone. Except when ground fault current is severally limited by neutral impedance there is usually no selectivity problem when such a problem exists, it is solved by use of an additional more sensitive relaying equipment including a supervising protective relay.



# Chapter 11

## Current Transformer Selection, Operation & Maintenance:

**Current Transformer:** For Selection, Operation, and Inspection & Maintenance:

In general, large currents (hundreds of amperes) cannot be directly input to powermeters for measuring power. Therefore, the current is passed through a CT (current transformer) prior to measurement. The following are some points regarding selection, operation, and maintenance of CTs.

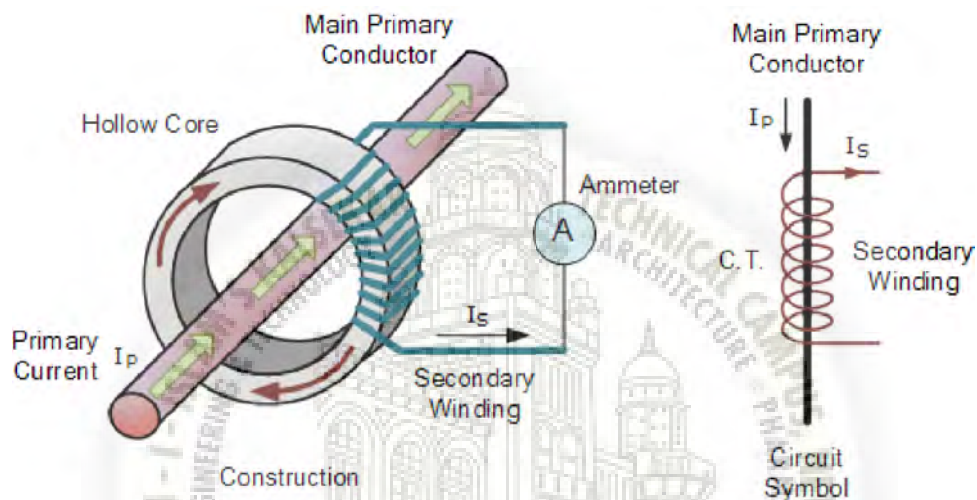

### 11.1 Selecting a CT:

1. Check the voltage of the circuit. Check the voltage of the circuit to be tested, then select a CT that supports that voltage.
2. Check the rated primary current. Choose a CT with a rated primary current that is slightly larger than the maximum current that will be measured (ex.: 100 A, 200 A, 300 A, 500 A, 800 A). The rated secondary current is typically 5 A, but there are also 1-A transformers. Single ampere CTs are useful for long-distance wiring.
3. Check the rated load. The load should be checked because it affects the wiring distance and other factors. See, "Operating a CT."



4. Ampere-turn: If the primary current is a few amperes, winding the primary cable around the CT several times will cause the secondary current to be multiplied by just the number of times the cable is wound, allowing you to extract it. For

example, if you wind a cable once around a 100 A/1 A CT, two turns of the cable will pass through the center of the CT resulting in a 50 A/1 A ratio.

1. Other:

To prevent accidents when the secondary circuit is open, it is safest to use a CT with a built-in voltage restraint.

## 11.2 Operating a CT:

1. The rated load is the sum of the distribution loss between the CT and instrument

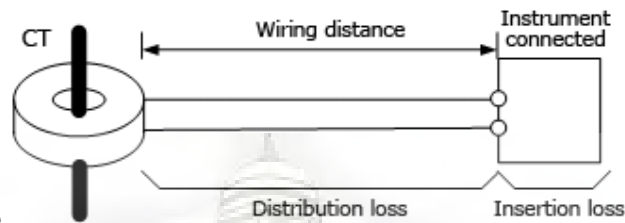

connected to the secondary side, and the insertion loss at the instrument connected to the secondary side. You should keep the value within this load rating, for example, an indication of 0.5 VA or 2.5 VA.

**CT rated load  $\geq$  distribution loss + insertion loss at secondary side**

To calculate the distribution loss, see (2) and (3) below.

2. Check the wiring distance and material. Loss grows proportionally larger with the wiring distance. The total length of the wiring materials is the distance both ways.

**Approx. Resistance in Wiring Material**  
**Nominal cross-sectional area: 1.25 mm<sup>2</sup> = Approx. 18  $\Omega$ /km**  
**Nominal cross-sectional area: 2.0 mm<sup>2</sup> = Approx. 10  $\Omega$ /km**

3. Examples (rough calculation)

**CT: rated primary current/rated secondary current = 100 A/1 A**  
**CT's rated load: 0.5 VA**

1. When using wiring material with a nominal cross-sectional area of 1.25 mm<sup>2</sup>

$$\text{Wiring resistance } R = 18 \Omega/\text{km} \times 0.015 \text{ km} \times 2 \text{ (both ways)} = 0.54 \Omega$$

1.

- Distribution loss  $\approx I^2R = (\text{rated secondary current})^2 \times \text{wiring resistance} = 1 \times 1 \times 0.54 = 0.54 \text{ VA}$

Condition: CT rated load > distribution loss + insertion loss of the instrument connected to the secondary side

This results in  $0.5 < 0.54 + 0.2 = 0.74$ , which is false (the condition is not met).

- When using wiring material with a nominal cross-sectional area of  $2.0 \text{ mm}^2$   
Wiring resistance  $R = 10 \text{ } \Omega/\text{km} \times 0.015 \text{ km} \times 2 = 0.3 \text{ } \Omega$   
Distribution loss  $\approx I^2R = (\text{rated secondary current})^2 \times \text{wiring resistance} = 1 \times 1 \times 0.3 = 0.3 \text{ VA}$   
Condition: CT rated load > distribution loss + insertion loss of the instrument connected to the secondary side  
This results in  $0.5 \geq 0.3 + 0.2 = 0.5$ , which is true (the condition is met).  
In the example above, wiring with a nominal cross-sectional area of  $2.00 \text{ mm}^2$  is required.



# Chapter 12

## Communication

They are basically two different method of communication in power system, they are:

- PLCC (Power line carrier communication)
- SDH (Synchronous Digital hierarchy)

PLCC is a older and conventional mode of communication in a power system as its name suggests, whereas SDH is modern fiber optic based high speed and reliable communication system in a power system

### 12.1 PLCC:

Use of plcc in modern electrical power system is mainly for telemetry and tele control. Tele means remote. Telemetry refers to science of measurement of remote location.

Different types of data transmission system can be used depending upon the network requirement and conditions. Each end of transmission line is provided with identical PLCC equipment consist of equipment.

1. Transmitter and receivers
2. Hybrids and filters
3. Line tunners
4. Line traps
5. Power amplifier
6. Coupling capacitors

Distance protection relay in relay panel at one end of the transmission line gets the input from CT and CVT in line. The output Of relay goes to modern of PLCC.

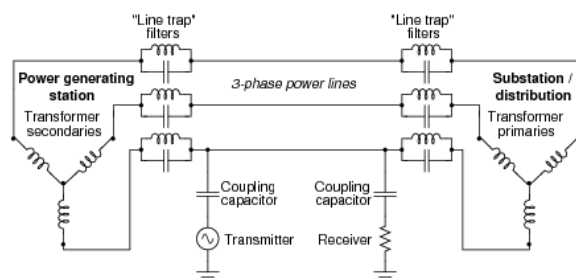

Figure 1

The output of PLCC goes to coupling capacitor and then to transmission line and travels to Another end where it is received through coupling capacitor and inputted to relay and control panel at that end.

PLCC communication is used basically for those electricity boards whose networks is very large and mainly consist of rural areas like MSETCL.

At Mumbai Transmission we use SDH communication which is discussed below.

## 12.2 SDH:

What does Synchronous Digital Hierarchy (SDH) mean ?

Synchronous digital hierarchy (SDH) is an international technology standard that utilizes light emitting diodes (LED) or lasers for synchronous optical fiber communication was developed

To eliminate synchronization issues and replace the plesiochronous digital hierarchy (PDH) System for bulk telephone and data exchange.

Is SDH the basic mod of communication is optical fiber cable, between the station this optical fiber cable is through OPGW (optical ground wire) presents at the top of transmission tower.

The main advantage of using optical fiber are as below:

- Increased bandwidth
- Less cost
- Small size
- Immunity to electromagnetic and radio interference.

The main of sending and receiving the data through fiber optic cable are:

- Light source

LED, VCSEL and LASER can be used as light source. At Mumbai Transmission we use LASER as light source.

- Light receiver
- Optical cable:

It can of two types as below :

1. Multi-mode: multimode fiber has a relatively large light carrying core, usually 62.5 Microns or large in diameter. It is usually used for short distance transmissions.
2. Single mode: single-mode fibre has a small light carrying core of 8 to 10 microns in diameter . it is usually used for long distance transmission.

The small form-factor pluggable (SFP) is a compact, hot-pluggable optical module transceiver used for both telecommunication and data communications applications.

SDH basically works on the principle of multiplexing, and incorporates TDM (time division multiplexing ) technique.

### 12.3 Applications of SDH in power system:

1. Line differential protection.
2. DT (direct trip) >used in case of LBB.
3. Distance protection .
4. BCC (Bbackup control centre) communication.
5. Load shedding scheme.

### 12.4 Some redundant applications are:

1. RMS (Relay Management System)>can extract disturbance graph of relays.
2. DTS(distributed temperature sensor)>Used I case of cables.
3. VOIP (voice over internet protocol)>for voice communications.

### 12.5 STM (Synchronous Transport Module):

The basic transport frame of an SDH network , operating at a minimum of 155mbps (STM 1).STM-1 can be multiplexed to create higher order STM, for example an STM-4 would be 4 x STM-1 and STM-16 would be 4x STM-4. SDH (synchronous digital hierarchy) uses the following STM (synchronous transport modules ) and rates: STM-1 (155mbps), STM-4 (622mbps), STM-16 (2.5Gbps), STM-64 (10Gbps).

At Mumbai transmissions we employ STM-4, and it consist of two channels in each stations. The different modules in a SDH panel and their functions are as below:

1. POSUM module: It is used to provide 5 V DC supply to other modules.
2. TEBIT: Used for distance protection communication.  
DISTANCE>TEBIT>SDH
3. OPTIF: Used for differential protection communication.  
DIFFERENTIAL>TEBIT>SDH
4. GECOD: Used for differential protection communication.  
For differential, C37.94>OPTIF (make is MiCOM/ABB)  
G703 (make is Siemens)
5. SYN4E: IS Used to synchronise all the data in above modules and communication between substations.
6. NEBRO: For BCC communication and load shedding scheme.

## 7. AFS Switch

**12.5 NMS (Network Management System):** SDH of all substations are managed through NMS.

Both SDH Scheme and Fiber network have redundancy for backup.

A complete different module is used for redundant application of SDH, because a failure in this module should not affect the primary protection communication at any cost.

## 12.6 SDH TESTING:

>Main component of to be tested in SDH is the fiber optic cable.

- There is a loss in the cable along in length which should not exceed a predefined limit. Hence the optic has to be tested for this value.

- Insertion and span losses are seen in fiber optics due to joints and bends.

- The equipment used to detect the losses is OLP315.

>OTDR (Optical Time Domain Reflector) is a device used to find faults, splices and bends in fiber optic cable.

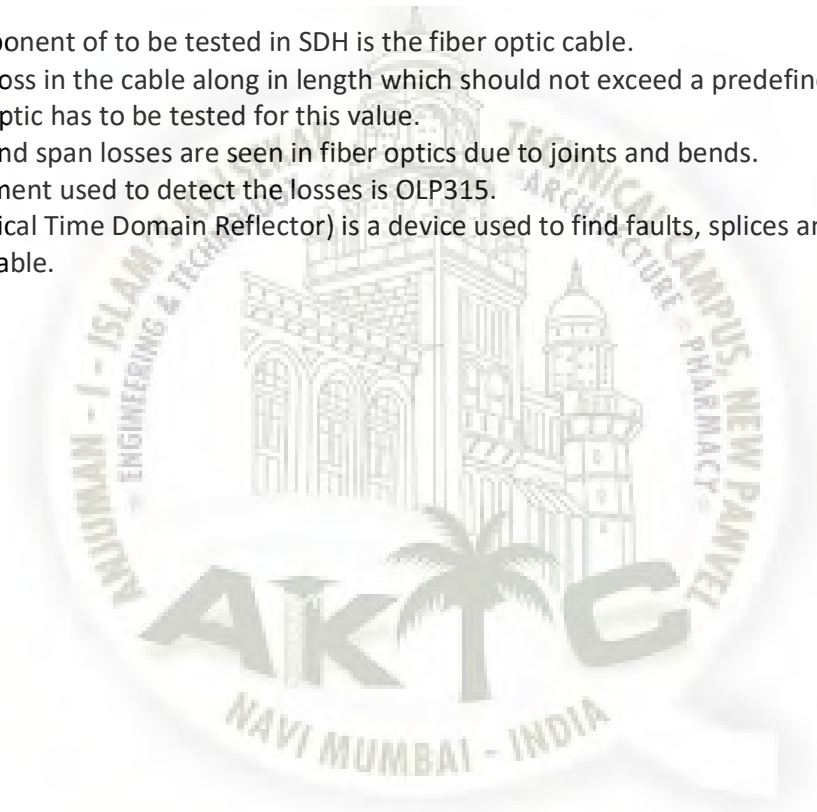



# Chapter 13

## SCADA:

Supervisory control and data acquisition (SCADA) IS a system of software and Hardware elements that allows industrial Organization to:

- . Control industrial processes locally or at remote locations
  - . monitor, gather, and process real-time data
  - .Directly interact with devices such as sensors, valves, pumps, motors, and more through human-machine interface (HMI) software
  - . Record events into a log file
- SCADA system are crucial for industrial organizations since they help to maintain efficiency, process data for smarter decisions, and communicate system issues

### 13.1 Why Scada?

One reason is that with scada, you can eliminate the need for side visits by your personnel for inspection, adjustment and data collection. SCADA software enables you to monitor the operation in real time. It can also make modification to the system, auto-generate reports and trouble shoot.

Thus, once the system is installed it reduces operation cost and improve the efficiency of the set-up. SCADA system are equipped to make immediate correction in the operational system, so they can increase the life-period of your equipment and save for the need for costly repairs. It also translate into man-hours saved and personnel enabled to focused on task that equire human involvement. Further, the auto-generated reporting system ensures compliance with regulatory principles.

The typical SCADA system comprises of,

1. sensors (either digital or analog): sensors control relays that directly interface with the managed system.
2. Remote telemetry units (RTU): these are small computerized units diploid in the field at specific sites and locations. It serves as local collection points for gathering information from sensors and delivering command to control relays.
3. Communications network: it connects the SCADA master station the RTU.
4. SCADA master units: These are larger computer consoles that serves as the central processor for the SCADA system. Master units provide a human interface to the system and automatically regulate the managed system I response to sensor inputs.
5. Remote Communication Server (RCS): The RCS communicates with the RTU and collect information which is also called master station. The master station, an HMI (Human

Machine Interface) or an HCI (human computer interface) performs data processing on information gathered from sensors.

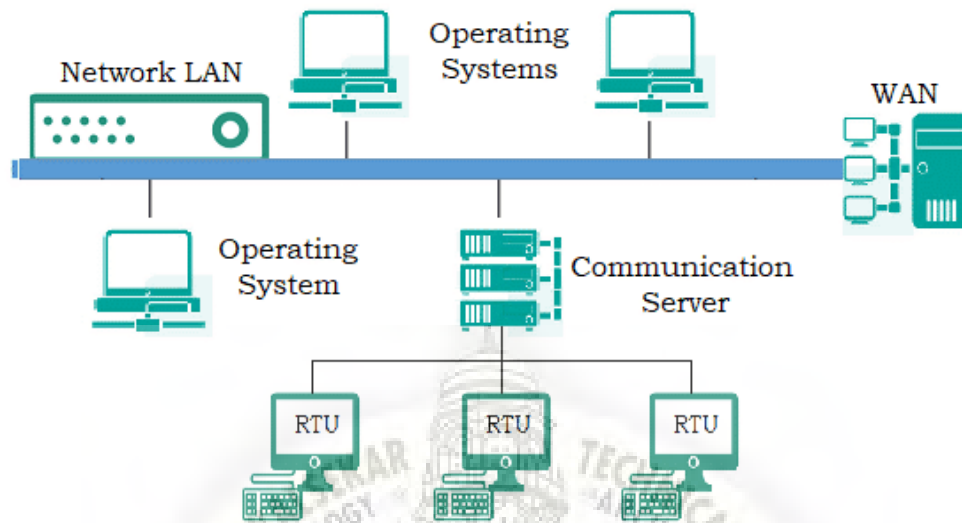

Figure 2

There are different types of SCADA system that can be considered as SCADA architectures of four different generations:

1. First generation : Monolithic or Early SCADA systems,
2. Second generation : Distributed SCADA systems,
3. Third generation : Networked SCADA systems and
4. Fourth generation : Internet of things technology, SCADA systems

### 13.2 MODBUS Protocol

Modbus is a protocol used for machine-to-machine communication in a wide variety of industrial application. The communication occurs over some kind of network transport. Modbus is generally used for remote monitoring and control where data is collected from and commands are issued to instrumentation and control devices.

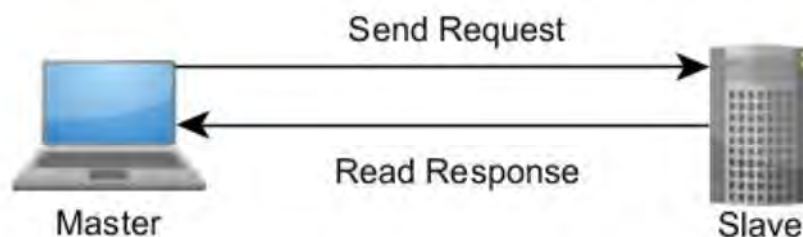

In modbus networks, there is typically one and multiple slave units. Modbus masters will either request information from or issue commands to Remote Telemetry Units (RTU).

Each RTU is assigned a unique Modbus address to enable data and commands to be routed correctly over a network. Traditionally a Modbus network was a multi-drop serial channel like RS-485 or RS-232 with appropriate unit isolation. In these traditional networks, up to 247 RTUs could be connected at one time. Modbus/TCP increases the number of units that can be connected to the same network.

The Modbus protocol can be used with two types of serial connections, both RS-232 and RS-485. Some versions of Modbus can also be sent over Ethernet or TCP/IP. These Modbus communications are packed as a single bit, or 16-bit Word packets.

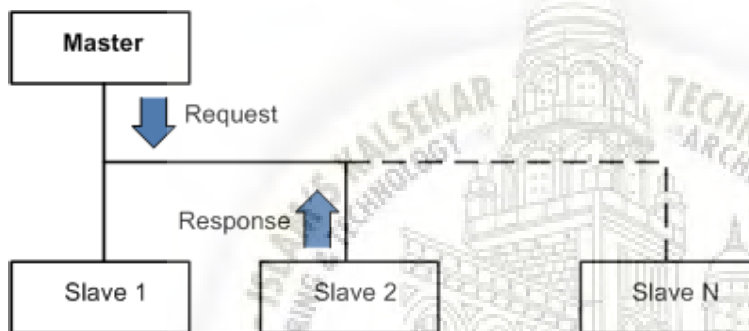

Figure 3

At Mumbai Transmission, Various protocols of SCADA are used,

1. At Aarey, Versova and Ghodbunder Stations the SCADA unit for AIS type system are hardwired and other work on the IEC (international electrotechnical committee)-103 protocol.
2. At Goregaon, Ghodbunder, Saki, Chembur the SCADA works on IEC-61850 based protocol.

**IEC 61850** is an international standard defining communication protocols for intelligent electronic devices at electrical substations. It is a part of the International Electrotechnical commission's (IEC) Technical committee 57 reference architecture for electric power systems.

The main advantage of using IEC61850 include:

- . offering a complete set of specifications covering all communication issues inside a substations.
- . Meeting the requirement for an integrated information management providing the user with consistent knowledge of the system on line, rather than just gigabytes of raw data.
- . Inter-operability between various manufactures' IED's, thus forming an integrated system.
- . Substation configuration Language (SCL).

- . Lowering installation and maintenance costs, with self-describing devices that reduce manual configuration.
- . Support for functions difficult to implement otherwise.

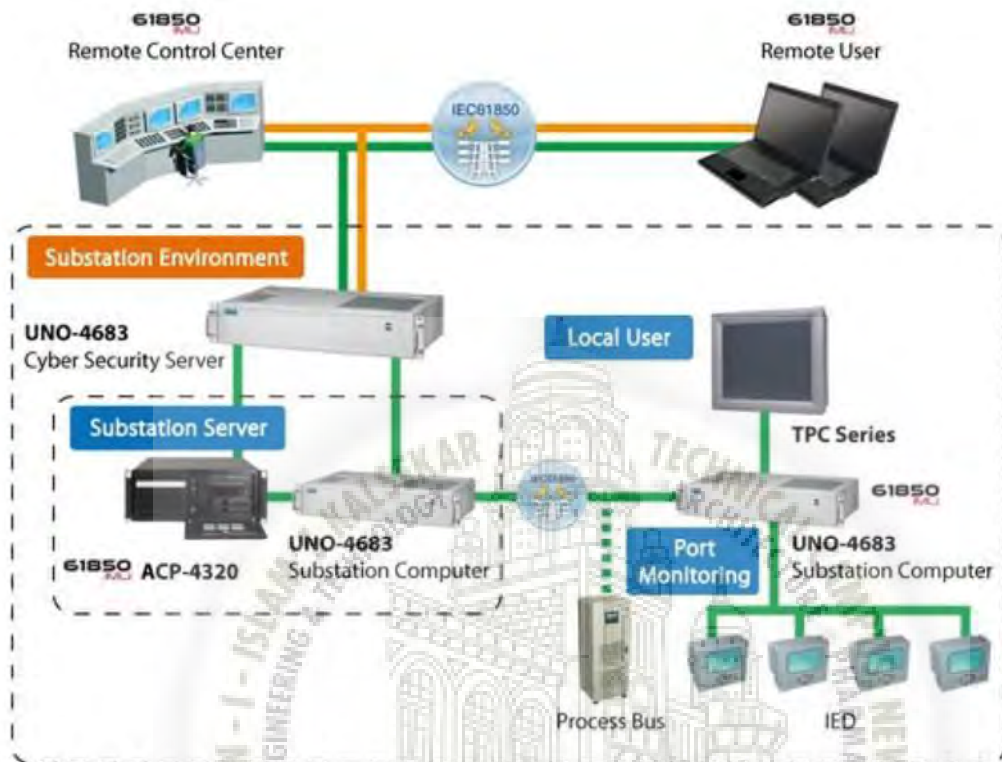

Figure 4

In IEC protocol, The main substation automation (SA) function consist of several sub-functions which are appropriately interfaced.

The sub function are assigned at three levels-(1) process level (2) Bay level (3) Station level

**Process level** function extracts the information from sensors/transducers in the substation and to send them to upper level device, called bay level device. The other major task of process level function is to receive the control command from bay level device and execute it at the appropriate switch level.

**Bay level** function acquire the data from the bay and the mainly act on the primary (power circuit) equipment of the bay. The CT, PT and actuator are connected to protection and control unit via merging unit. Merging unit is a device to collect the instantaneous values of current and voltage from CT, and PT, sample the same and send them to the protection and control unit. Protection unit and control unit are bay level devices. Bay level device collect data from the same the bay and/or from different bays and perform actions on the primary equipment in its own bay.

**Station level** functions are of two types-

1. Process related functions act on the data from multiple bays or substation level database. These functions are used to submit the control commands for the primary equipment (circuit breakers) and collect the substation data like voltage, current, power factor etc. from the bay level devices. As described in the bay configuration of the report, each bay includes one primary equipment such as transformer, feeders etc.
2. Interface related functions enable interactive interface of the substation automation system to the local station operator HMI (Human Machine Interface), to a remote control center (Station Control Room) or to the remote monitoring center for monitoring and maintenance (BCC).

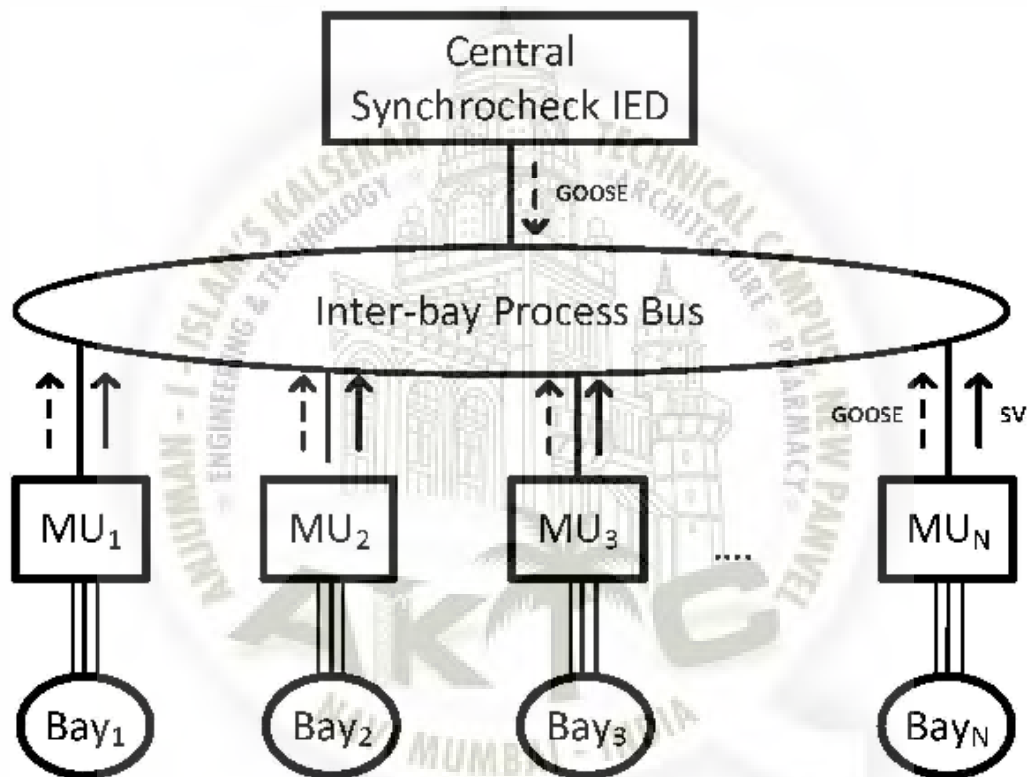

Conceptual Station Bays

Figure 5

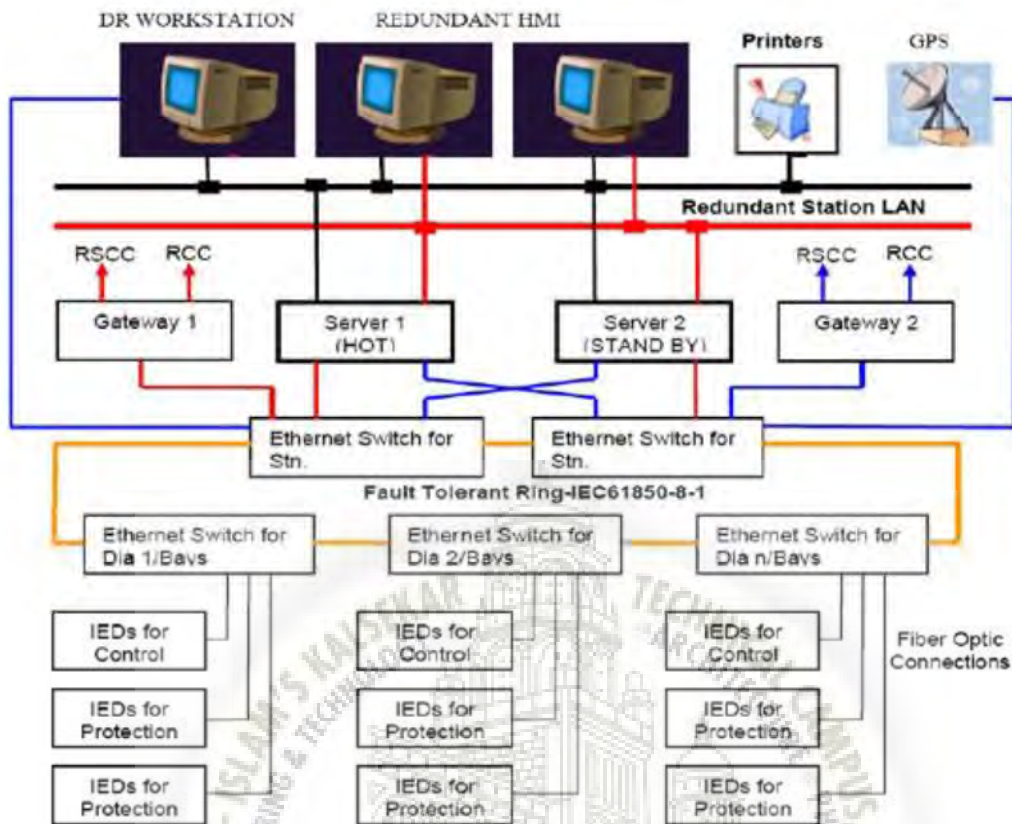

Typical Communication System in a Substation

Figure 6

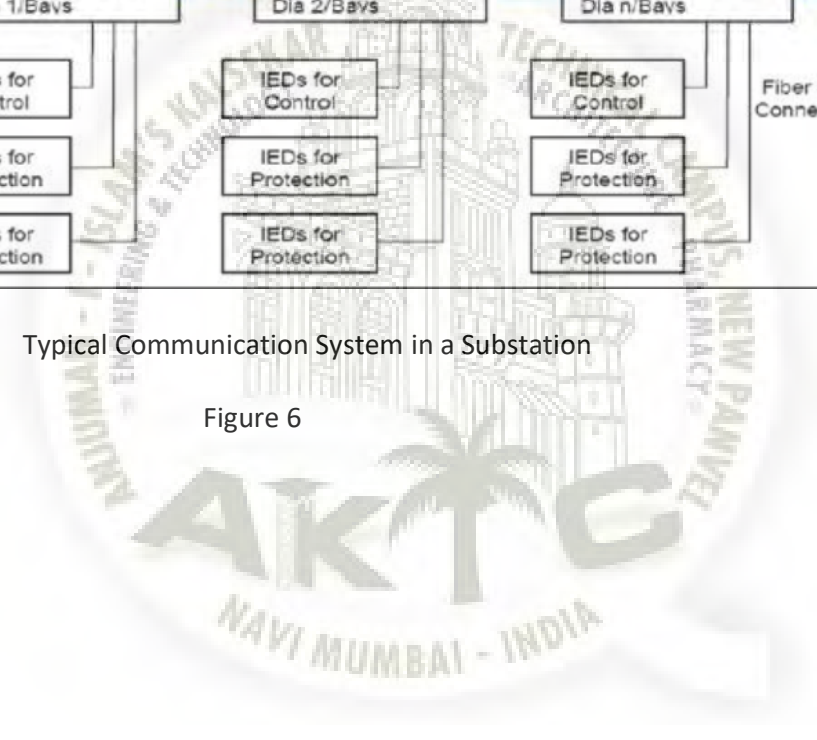

# Chapter 14

## Precautions Regarding Inspection and Maintenance:

**N**ever work on live wires. High voltage is generated when current is flowing through the CT and the secondary circuit is open. It is extremely dangerous to leave the device in a state in which dielectric breakdown seems likely to occur, as burns or fires can result. Therefore, always short the CT's secondary circuit before turning on the electricity after performing maintenance. Recently, CTs with built-in voltage restraints for the secondary circuit have become available.



## Reference

- [1]. Andruşca, M., Adam, M., Baraboi, A., Irimia, D.F., Aspects regarding the asset management of the electrical equipment into a power station. International Conference on Electrical Engineering and Energy Converts, Suceava, 2011.
- [2]. McCalley J., Kezunovic, M., Natti, S., Automated Integration of Condition Monitoring with an Optimized Maintenance Scheduler for Circuit Breakers and Power Transformers. Power Systems Engineering Research Centre, 2006.
- [3]. Pancu, C., Adam, M., Baraboi, A., Roman, C., New possibility for the electro erosion estimation of the circuit breakers contacts. 8th WSEAS International Conference on Electric Power Systems, High Voltages, Electric Machines "POWER '08", Venice, Italia, pp. 81-84, 2008.
- [4]. Ray Mohapatra, S. K., Mukhopadhyay, S., Risk and Asset Management of Transmission System in a Reformed Power Sector. Power India Conference, 2006.
- [5]. Endrenyi, J., Introduction to maintenance, IEEE tutorial on asset management—maintenance and replacement strategies, Tampa, USA, 2007.

## Achievement

Paper Type :: Research Paper  
Title :: **Maintenance of 220kv Substation Equipment**  
Country :: India  
Authors :: Khan Azharuddin || Shaikh Gulam Jilani || Sayed Mohd Javed ||  
Chaudhary Mushtaque || Yakub Khan || Sayed Kaleem  
Page No. :: 60-63