

# ELECTRIC GENERATION BY SPINNING EXERCISE

*Project Stage-II*

*Report Submitted*

*In*

*Partial fulfillment of requirement*

*For the award of degree of*

**Bachelor of Engineering**

**In**

**Electrical Engineering**

*Submitted by*

<b>SAYYED FARZEEN</b>	<b>16EE03</b>
<b>ANIS ANSARI</b>	<b>16EE07</b>
<b>TUFAIL BARGIR</b>	<b>16EE10</b>
<b>ALTAMASH SHAIKH</b>	<b>16EE28</b>

*Under the guidance of*

**PROF. TANVEER HUSAIN KHATIK**



**Department of Electrical Engineering**

Anjuman-I-Islam's Kalsekar Technical Campus, Panvel

Mumbai University, Mumbai

2019-2020

# **ELECTRIC GENERATION BY SPINNING EXERCISE**

*Project Stage-II*

*Report Submitted*

*In*

*Partial fulfillment of requirement*

*For the award of degree of*

**Bachelor of Engineering**

**In**

**Electrical Engineering**

*Submitted by*

<b>SAYYED FARZEEN</b>	<b>16EE03</b>
<b>ANIS ANSARI</b>	<b>16EE07</b>
<b>TUFAIL BARGIR</b>	<b>16EE10</b>
<b>ALTAMASH SHAIKH</b>	<b>16EE28</b>

*Under the guidance of*

**PROF. TANVEER HUSAIN KHATIK**



**Department of Electrical Engineering**

Anjuman-I-Islam's Kalsekar Technical Campus, Panvel

Mumbai University, Mumbai

2019-2020

© Anjuman-I-Islam's Kalsekar Technical Campus-2020

## CERTIFICATE

This to verify that the dissertation titled “**ELECTRIC GENERATION BY SPINNING EXERCISE**”, which is being submitted herewith for the award of the, ‘**Bachelor of Engineering**’ in **Electrical Engineering** of Anjuman-I-Islam’s Kalsekar Technical Campus, New Panvel (M.S, India). This is the result of the original research work and contributed by ‘**Ms. FARZEEN SAYYED, Mr. TUFAIL BARGIR, Mr. ANIS ANSARI, Mr. ALTAMASH SHAIKH**’ under guidance and supervision. The work embodied in this dissertation has not formed earlier for the basis of award of any degree or compatible certificate or similar title of this for any other diploma/examining body or university to the best of knowledge and belief.

Place: Panvel

Date: / / 2020

Prof. Tanveer Husain Khatik

**Guide**

Prof. Kaleem Sayyed

**H.O.D.**

Dr. Abdul Razzak Honutagi

**Director**

## Acknowledgement

It is our pleasure and privilege to present this project on ELECTRIC GENERATION BY SPINNING EXERCISE. We are very grateful to head of the department *Mr. Sayyed Kaleem* for the valuable guidance and for the support in making this report. We would like to express our sincere thanks to *Prof. Tanveer Hussain K.* for all the valuable inputs and suggestions shared for making this report. We are immensely thankful to all the faculties and staff members of Electrical Engineering for their cooperation.

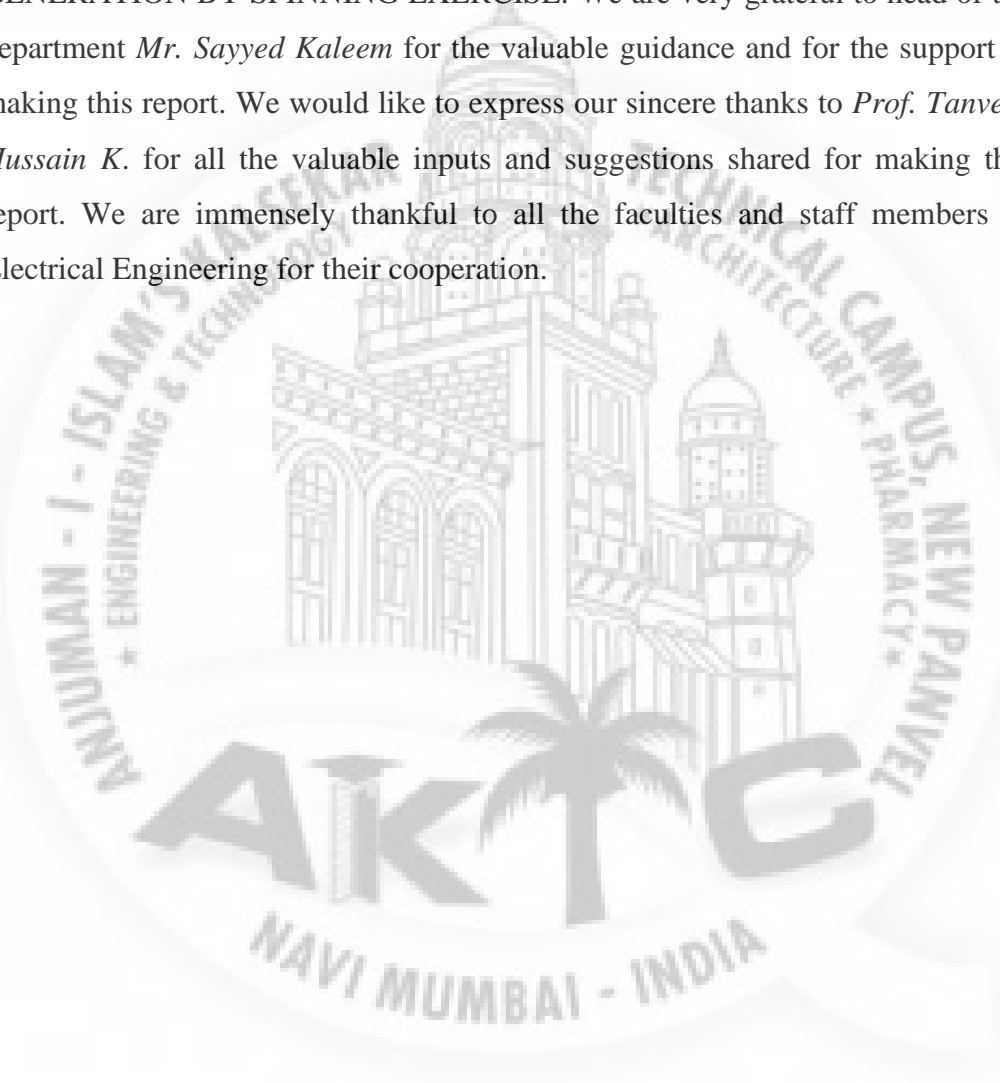

## TABLE OF CONTENT

Serial no.	Content	Page No.
	Abstract	i
	List of Figures	ii
1:	Introduction	(1-3)
	1.1 Introduction	1
	1.2 Objectives	2
	1.3 Application of Pedal Powered Generator	2
	1.4 Layout of Paper	2
2:	Energy Resource Analysis	(4-14)
	2.1 Energy Resources in the World	4
	2.1.1 Coal	5
	2.1.2 Natural Gas	6
	2.1.3 Fossil Fuel	7
	2.1.4 Radioactive Fuel	7
	2.1.5 Solar Energy	8
	2.1.6 Wind Power	8
	2.1.7 Hydro Power	9
	2.1.8 Geothermal Energy	10
	2.2 Future Generation Scenario Demand Projection	11
	2.3 Selection of Battery	11
	2.4 Battery Ratings	12
	2.5 Selection of Bicycle	13
3:	Description of Pedal Power Generator	(15-24)
	3.1 Design Steps	15
	3.2 Major Components	16
	3.3 Working Principle	17
	3.4 Power Transmission	20

	3.5 Calculation of Belt-Pulley Selection	21
	3.6 Electrical Circuit Connection Diagram	24
4:	Permanent Magnet DC Motor	(25-28)
	4.1 Types of Permanent Magnet Materials	27
	4.2 Applications	27
	4.3 Advantages	28
	4.4 Disadvantages	28
5:	Bicycle and Load	(29-32)
	5.1 The Bicycle	29
	5.1.1 The Frame	30
	5.1.2 Drive train and Gearing	30
	5.1.3 Steering and Seating	31
	5.2 Loads	31
	5.2.1 Fluorescent Bulb	31
	5.2.2 Fan	32
6:	Discussion	(33-34)
	6.1 Outcome of the Project	33
	6.2 Limitations	33
7:	Conclusions and Recommendations	35
	7.1 Introduction	35
	7.2 Further improvement	35
	References	(36-39)

## Abstract

Pedal powered generator is a device that uses human energy to produce electricity for charging a battery. Here an alternator is used as the electricity generator. The alternator is coupled to a pulley which is rotated by a belt and chain-sprocket system of a bicycle structure. The power is given to the paddle and final rotational speed is achieved in the alternator rotor.

Most components of the portable pedal power generator are based upon existing inventions, both recent and historic. The real innovation behind this power generator is portability. University groups often organize events around and off campus. Therefore, mobility of equipment is of great importance. This innovation brings together the resourcefulness of pedal power generation with the transportation feasibility of a bicycle frame. The integrated unit will generate needed electricity on-site, and transport it to the site with pedal power. During transportation, the unit can also capture energy used in braking and coasting. A photovoltaic panel could further the energy production while demonstrating the potable potential. We think our pedal powered device will inspire students and the public to think about the realities of energy production, which may spark new energy solution.

In our country it can be used in the villages as useful electricity source for a small family where the family themselves charge the battery by paddling for a short period of time each. This will not only provide electricity when needed but also provide a useful way of physical exercise for them. And due to the low due to initial cost and very low maintenance cost, wide scale application of 'Pedal Power Generator' can be suitable source of renewable energy

## LIST OF FIGURES

Figure No.	Title	Page No.
Figure 2.3	General Bicycle	13
Figure 2.4	Racing Cycle	14
Figure 3.1	Initial Design of Pedal Powered Generator	15
Figure 3.2	Modified Design of the Setup	16
Figure 3.3	Approved Design of Pedal Powered Generator	16
Figure 3.4	Pedal Power Generator Setup	17
Figure 3.5	Typical Alternator Circuit	19
Figure 3.6	Electrical Circuit Diagram	24
Figure 4.1	Cross Sectional View of 2 pole PMDC motor	25
Figure 4.2	Circuit Diagram of PMDC motor	26
Figure 5.1	Different Parts of the Bicycle	29



# 1. Introduction

## 1.1 Introduction

Pedal powered generators have been of interest at many places where no other alternative electricity generator has been viable. While using pedal power is not a new concept in itself, it has not been successfully used on a wider scale.

Pedal powered generator is a device that uses human energy to produce electricity for charging a battery. Here an alternator is used as the electricity generator. The alternator is coupled to a pulley which is rotated by a belt and chain- sprocket system of a bicycle structure. The input power is given to the pedal and final rotational speed is achieved in the alternator rotor.

Most components of the portable pedal power generator are based upon existing inventions, both recent and historic. The real innovation behind this power generator is portability. University groups often organize events around and off campus. Therefore, mobility of equipment is of great importance. This innovation brings together the resourcefulness of pedal power generation with the transportation feasibility of a bicycle frame. The integrated unit will generate needed electricity on-site, and transport it to the site with pedal power. During transportation, the unit can also capture energy used in braking and coasting. A photovoltaic panel could further the energy production while demonstrating the portable potential. We think our pedal-powered device will inspire students and the public to think about the realities of energy production, which may spark new energy solution.

By using this pedal powered generator, different types of equipment, such as, TV, radio, CD player etc. can be run by using pedal power. Pedal powered

generator is very useful to those areas, which areas do not have electricity connection.

The pedal power generator stores energy to a battery which provides electricity in DC form, if AC type of electricity is required, an inverter is connected.

## 1.2 Objectives

The goal of pedal powered generator is to find a fun way to bring energy into the output, reduce consumption, or just enjoy more productive physical exercise; Pedal power can supply turnkey solutions or components for larger projects or exhibitions.

## 1.3 Application of Pedal Powered Generator

1. Pedal powered generator can be used to charge the battery which may be a great opportunity of people of remote area to use telecommunication system.
2. It can be a great source of light during night time and save a great amount of electricity.
3. Pedal powered generator can be used to operate the machines such as
  - a) Photocopy machine.
  - b) Fax.
  - c) Printer.
  - d) Computer.
  - e) Water pumping machine.
  - f) Laptop computer

g) TV

## 1.4 Layout of the thesis paper

In the first chapter, the main goal of this project is expressed. This chapter also shows the possible implementation of this idea in practical field.

Second chapter highlights the energy sources of the world. It mainly shows the energy crisis. Selection of battery and selection of alternator is also included in the battery.

Third chapter describes the whole setup. Working principle and mechanism of power transmission is described here. Electrical circuit connection diagram and calculation of belt pulley selection also included here.

The fourth chapter describes the construction of PMDC motor. Also its types, applications, advantages and disadvantages.

The fifth chapter contain the complete description of a bicycle.

Discussion and conclusion are covered in the last.

## 2. Energy Resource Analysis

### 2.1 Energy Resources in the World

In physics, energy (Ancient Greek: ἐνέργεια *energeia* "activity, operation" is an indirectly observed quantity. It is often understood as the ability a physical system has to do work on other physical systems . Since work is defined as a force acting through a distance (a length of space), energy is always equivalent to the ability to exert pulls or pushes against the basic forces of nature, along a path of a certain length.

Energy can be divided into 2 categories. They are

1. Renewable energy.
2. Non-renewable energy.

Renewable energy is energy which comes from natural resources such as sunlight, wind, rain, tides, and geothermal heat, which are renewable (naturally replenished). About 16% of global final energy consumption comes from renewables, with 10% coming from traditional biomass, which is mainly used for heating, and 3.4% from hydroelectricity. New renewables (small hydro, modern biomass, wind, solar, geothermal, and biofuels) accounted for another 2.8% and are growing very rapidly]. The share of renewables in electricity generation is around 19%, with 16% of global electricity coming from hydroelectricity and 3% from new renewables

While many renewable energy projects are large-scale, renewable technologies are also suited to rural and remote areas, where energy is often crucial in human development. As of 2011, small solar PV systems provide electricity to a few million households, and micro-hydro configured into mini-grids serves many more. Over 44 million households use biogas made in household-scale digesters for lighting and/or

cooking and more than 166 million households rely on a new generation of more-efficient biomass cook-stoves].

A non-renewable resource is a natural resource which cannot be produced, grown, generated, or used on a scale which can sustain its consumption rate, once depleted there is no more available for future needs. Also considered non-renewable are resources that are consumed much faster than nature can create them. Fossil fuels (such as coal, petroleum, and natural gas), types of nuclear power (uranium) and certain aquifers are examples. In contrast, resources such as timber (when harvested sustainably) or metals (which can be recycled) are considered renewable resources.

Some major sources of renewable and non-renewable sources are discussed below:

1. Radioactive fuel.
2. Crude oil.
3. Natural Gas.
4. Coal

Main sources of renewable energy are

1. Wind power.
2. **Hydropower.**
3. Solar energy.
4. Biomass.
5. Biofuel.
6. Geothermal energy.

### 2.1.1 Coal

Coal is a combustible black or brownish-black sedimentary rock normally occurring in rock strata in layers or veins called coal beds or coal seams. The harder forms, such as anthracite coal, can be regarded as metamorphic rock because of later exposure to elevated temperature and pressure. Coal is composed primarily of carbon along with variable quantities of other elements, chiefly hydrogen, with smaller quantities of sulfur, oxygen and nitrogen.

Coal begins as layers of plant matter accumulating at the bottom of a body of water. For the process to continue, the plant matter must be protected from biodegradation and oxidization, usually by mud or acidic water. This trapped atmospheric carbon in the ground in immense peat bogs that eventually were covered over and deeply buried by sediments under which they metamorphosed into coal. Over time, the chemical and physical properties of the plant remains were changed by geological action to create a solid material].

The wide shallow seas of the Carboniferous period provided ideal conditions for coal formation, although coal is known from most geological periods. The exception is the Coal gap in the Lower Triassic, where coal is incredibly rare: presumably a result of the mass extinction which prefaced this era. Coal is even known from Precambrian strata, which predate land plants: this coal is presumed to have originated from algal residue

Coal, a fossil fuel, is the largest source of energy for the generation of electricity worldwide, as well as one of the largest worldwide anthropogenic sources of carbon dioxide releases. Gross carbon dioxide emissions from coal usage are slightly more than those from petroleum and about double the amount from natural gas].Coal are extracted from the ground by mining, either underground by shaft mining through the seams or in open pits.

### 2.1.2 Natural gas

Natural gas is a gas consisting primarily of methane, typically with 0–20% higher hydrocarbons] (primarily ethane). It is found associated with other hydrocarbon fuel, in

coal beds, as methane clathrates, and is an important fuel source and a major feedstock for fertilizers.

Most natural gas is created by two mechanisms: biogenic and thermogenic. Biogenic gas is created by methanogenic organisms in marshes, bogs, landfills, and shallow sediments. Deeper in the earth, at greater temperature and pressure, thermogenic gas is created from buried organic material].

Before natural gas can be used as a fuel, it must undergo processing to remove almost all materials other than methane. The by-products of that processing include ethane, propane, butanes, pentanes, and higher molecular weight hydrocarbons, elemental sulfur, carbon dioxide, water vapor, and sometimes helium and nitrogen.

Natural gas is often informally referred to as simply gas, especially when compared to other energy sources such as oil or coal.

### **2.1.3 Fossil fuel**

Fossil fuels are fuels formed by natural processes such as anaerobic decomposition of buried dead organisms. The age of the organisms and their resulting fossil fuels is typically millions of years, and sometimes exceeds 650 million years. The fossil fuels, which contain high percentages of carbon, include coal, petroleum, and natural gas. Fossil fuels range from volatile materials with low carbon: hydrogen ratios like methane, to liquid petroleum to nonvolatile materials composed of almost pure carbon, like anthracite coal. Methane can be found in hydrocarbon fields, alone, associated with oil, or in the form of methane clathrates. It is generally accepted that they formed from the fossilized remains of dead plants by exposure to heat and pressure in the Earth's crust over millions of years. This biogenic theory was first introduced by Georg Agricola in 1556 and later by Mikhail Lomonosov in the 18th century.

It was estimated by the Energy Information Administration that in 2007 primary sources of energy consisted of petroleum 36.0%, coal 27.4%, natural gas 23.0%,

amounting to an 86.4% share for fossil fuels in primary energy consumption in the world]. Non-fossil sources in 2006 included hydroelectric 6.3%, nuclear 8.5%, and others (geothermal, solar, tide, wind, wood, waste) amounting to 0.9 percent. World energy consumption was growing about 2.3% per year.

#### **2.1.4 Radioactive fuel**

Radioactive fuel is a material that can be 'consumed' by fission or fusion to derive nuclear energy. Radioactive nuclear fuels are the densest sources of energy available. Nuclear fuel in a nuclear fuel cycle can refer to the fuel itself, or to physical objects (for example bundles composed of fuel rods) composed of the fuel material, mixed with structural, neutron moderating, or neutron reflecting materials.

Most nuclear fuels contain heavy metal fissile elements that can be made to undergo a nuclear fission chain reaction in a nuclear reactor. The most common fissile nuclear fuels are Uranium 235 ( $^{235}\text{U}$ ) and Plutonium 239 ( $^{239}\text{Pu}$ ). The actions of mining, refining, purifying, using, and ultimately disposing of these elements together make up the nuclear fuel cycle.

Not all nuclear fuels are used in fission reactors. Plutonium-238 and some other elements are used to produce small amounts of nuclear power by radioactive decay in radioisotope thermoelectric generators and other atomic batteries. Light nuclides such as  $^3\text{H}$  (tritium) are used as fuel for nuclear fusion.

#### **2.1.5 Solar energy**

Solar energy, radiant light and heat from the sun, has been harnessed by humans since ancient times using a range of ever-evolving technologies. Solar radiation, along with secondary solarpowered resources such as wind and wave power, hydroelectricity and biomass, account for most of the available renewable energy on earth. Only a minuscule fraction of the available solar energy is used.

Solar powered electrical generation relies on heat engines and photovoltaics. Solar energy's uses are limited only by human ingenuity. A partial list of solar applications includes space heating and cooling through solar architecture, potable water



via distillation and disinfection, day lighting, solar hot water, solar cooking, and high temperature process heat for industrial purposes. To harvest the solar energy, the most common way is to use solar panels.

Solar technologies are broadly characterized as either passive solar or active solar depending on the way they capture, convert and distribute solar energy. Active solar techniques include the use of photovoltaic panels and solar thermal collectors to harness the energy. Passive solar techniques include orienting a building to the Sun, selecting materials with favorable thermal mass or light dispersing properties, and designing spaces that naturally circulate air.

The Earth receives 174 petawatts (PW) of incoming solar radiation (insolation) at the upper atmosphere. Approximately 30% is reflected back to space while the rest is absorbed by clouds, oceans and land masses. The spectrum of solar light at the Earth's surface is mostly spread across the visible and near-infrared ranges with a small part in the near-ultraviolet.

### **2.1.6 Wind power**

Wind power is the conversion of wind energy into a useful form of energy, such as using wind turbines to make electricity, windmills for mechanical power, wind pumps for water pumping or drainage, or sails to propel ships.

Wind power, as an alternative to fossil fuels, is plentiful, renewable, widely distributed, clean, and produces no greenhouse gas emissions during operation. A large wind farm may consist of several hundred individual wind turbines which are connected to the electric power transmission network. At the end of 2010, worldwide nameplate capacity of wind-powered generators was 197 GW. Energy production was 430 TWh, which is about 2.5% of worldwide electricity usage]. Several countries have achieved relatively high levels of wind power penetration, such as 21% of stationary electricity production in Denmark, 18% in Portugal, 16% in Spain, 14% in Ireland and 9% in Germany in 2010. As of 2011, 83 countries around the world are using wind power on a commercial basis.

### 2.1.7 Hydro power

Hydropower, hydraulic power or water power is power that is derived from the force or energy of moving water, which may be harnessed for useful purposes. Prior to the development of electric power, hydropower was used for irrigation, and operation of various machines, such as watermills, textile machines, sawmills, dock cranes, and domestic lifts.

Another method used a trompe to produce compressed air from falling water, which could then be used to power other machinery at a distance from the water.

In hydrology, hydropower is manifested in the force of the water on the riverbed and banks of a river. It is particularly powerful when the river is in flood. The force of the water results in the removal of sediment and other materials from the riverbed and banks of the river, causing erosion and other alterations.

Hydropower has been used for hundreds of years. In India, water wheels and watermills were built; in Imperial Rome, water powered mills produced flour from grain, and were also used for sawing timber and stone; in China, watermills were widely used since the Han Dynasty. The power of a wave of water released from a tank was used for extraction of metal ores in a method known as hushing. The method was first used at the Dolaucothi gold mine in Wales from 75 AD onwards, but had been developed in Spain at such mines as Las Medulas. Hushing was also widely used in Britain in the Medieval and later periods to extract lead and tin ores. It later evolved into hydraulic mining when used during the California gold rush.

In China and the rest of the Far East, hydraulically operated "pot wheel" pumps raised water into irrigation canals. At the beginning of the Industrial revolution in Britain, water was the main source of power for new inventions such as Richard Arkwright's water frame [23]. Although the use of water power gave way to steam power in many of the larger mills and factories, it was still used during the 18th and 19th centuries for many smaller operations, such as driving the bellows in small blast furnaces (e.g. the Dyfi Furnace) [24] and gristmills, such as those built at Saint Anthony Falls, which uses the 50-foot (15 m) drop in the Mississippi River.

### **2.1.8 Geothermal energy**

Geothermal energy is thermal energy generated and stored in the Earth. Thermal energy is energy that determines the temperature of matter. Earth's geothermal energy originates from the original formation of the planet, from radioactive decay of minerals and from volcanic activity. The geothermal gradient, which is the difference in temperature between the core of the planet and its surface, drives a continuous conduction of thermal energy in the form of heat from the core to the surface.

From hot springs, geothermal energy has been used for bathing since Paleolithic times and for space heating since ancient Roman times, but it is now better known for electricity generation. Worldwide, about 10,715 MW of geothermal power is online in 24 countries. An additional 28 GW of direct geothermal heating capacity is installed for district heating, space heating, spas, industrial processes, desalination and agricultural applications.

Geothermal power is cost effective, reliable, sustainable, and environmentally friendly, but has historically been limited to areas near tectonic plate boundaries. Recent technological advances have dramatically expanded the range and size of viable resources, especially for applications such as home heating, opening a potential for widespread exploitation. Geothermal wells release greenhouse gases trapped deep within the earth, but these emissions are much lower per energy unit than those of fossil fuels. As a result, geothermal power has the potential to help mitigate global warming if widely deployed in place of fossil fuels.

## **2.2 Future Generation Scenario Demand Projection**

BPDB has carried out a Power System Master Plan Study in 1995 to identify least cost power development plan up to 2015. In the PSMP, the benchmark load forecast was based on 8% growth rate. However, due to shortage in generation capacity, the actual demand could not be supplied. The minimum demand served so far is 2823 MW (27.07.2000). The Government's Vision is to provide affordable and reliable supply of electricity to all of the year 2020. Therefore, the electricity development is required to be accelerated to increased access and attain economic development. The desirable

economic growth rate would be about 6-7% p.u. considering these aspects, it would be logical to use the high forecast of demand as given in the PSMP-95. Based' upon the High Forecast from FY2003 onwards, the anticipated peak demand would be about 6071 MW in FY2007 and 11439 MW in FY2015. According to this Forecast, the average growth rate between 2000-2007 is 9.83% and 8.98% between 2000-2015. Generation Capacity expansion. In order to meet the projected demand reliably, various generation and transmission projects along with distribution expansion have been identified. These are under various stages of implementation. The generation capacity (including existing, under construction and planned capacity) would be about 7463 MW by 2007. Out of which IPP capacity would stand at 2050 MW

### 2.3 Selection of Battery

. Battery selection depends on load. Capacity of the battery must be increased for the higher power consumption. A sample calculation for selection of battery is provided below:

$$\text{Total Watt-Hr} = 230.0 \text{ WHr}$$

$$\text{Battery Voltage} = 12\text{V}$$

$$\text{Ampere-Hr} = (230/12) \text{ AHr}$$

$$= 19.2 \text{ AHr @ 4 Hr}$$

$$\text{Assume, Depth of Discharge (DOC)} = 70\%$$

$$\text{Then Ampere Hour} = (19.2/7) \text{ AHr}$$

$$= 27.44 \text{ AHr @ 4Hr}$$

The battery is rated at 20 hour for discharging. So efficiency falls down.

Efficiency, if the battery discharge rate at 5 Hr = 75%

Efficiency, if the battery discharge rate at 3 Hr = 66% So,

$$\begin{aligned} \text{Efficiency, if the battery discharge rate at 4 Hr} &= (75\%+66\%)/2 \\ &= 70.5\% \end{aligned}$$

$$\begin{aligned} \text{Recommended battery} &= (27.44/.705) \text{ Ahr} \\ &= 38.92 \text{ Ahr} \\ &= 40 \text{ Ahr (Available at stock)} \end{aligned}$$

## 2.4 Battery ratings

In general terms, the capacity of a cell/battery is the amount of charge available expressed in ampere-hours (Ah). An ampere is the unit of measurement used for electrical current and is defined as a coulomb of charge passing through an electrical conductor in one second. The capacity of a cell or battery is related to the quantity of active materials in it, and the amount of electrolyte and the surface area of the plates. The capacity of a battery/cell is measured by discharging at a constant current until it reaches its terminal voltage (usually about 1.75 volts). This is usually done at a constant temperature, under standard conditions of 25°C (77°F). The capacity is calculated by multiplying the discharge current value by the time required to reach terminal voltage.

The most common term used to describe a battery's ability to deliver current is its rated capacity. Manufacturers frequently specify the rated capacity of their batteries in ampere-hours at a specific discharge rate. For example, this means that a lead-acid battery rated for 200 Ah (for a 10-hour rate) will deliver 20 amperes of current for 10 hours under standard temperature conditions (25°C or 77°F). Alternatively, a discharge rate may be specified by its charge rate or C-rate, which is expressed as a multiple of the rated capacity of the cell or battery. For example, a battery may have a rating of 200 Ah at a C/10 discharge rate. The discharge rate is determined by the equation below:

$$\text{C/10 rates (amperes)} = 200\text{Ah}/10\text{h} = 20\text{A}$$

Battery capacity varies with the discharge rate. The higher the discharge rate, the lower the cell capacity. Lower discharge rates result in higher capacity. Manufacturer's

literature on batteries will normally specify several discharge rates (in amperes) along with the associated discharge time (in hours). The capacity of the battery for each of these various discharge rates can be calculated as discussed above.

The rated capacity for lead-acid batteries is usually specified at the 8-, 10-, or 20-hour rates ( $C/8$ ,  $C/10$ ,  $C/20$ ). UPS batteries are rated at 8-hour capacities and telecommunications batteries are rated at 10-hour capacities.

## 2.5 Selection of Bicycle

Pedaling is the operating force of the bicycle. So bicycle frame is the best option for the pedal power generator setup. General bicycle is enough for this purpose. If suitable base is joined with the cycle frame then it will be fully prepared for the setup.



Figure 2.3: General bicycle.

But general cycle has single geared power transmission and it is not capable of raising speed in short time. The simple solution of this problem is racing cycle. Racing cycle has multigeared power transmission system which provides the opportunity to increase the speed in very less time by increasing the gear ratio.



Figure 2.4: Racing cycle.

Racing cycle is more expensive than general cycle but it is the most available and easy solution of setup problem.

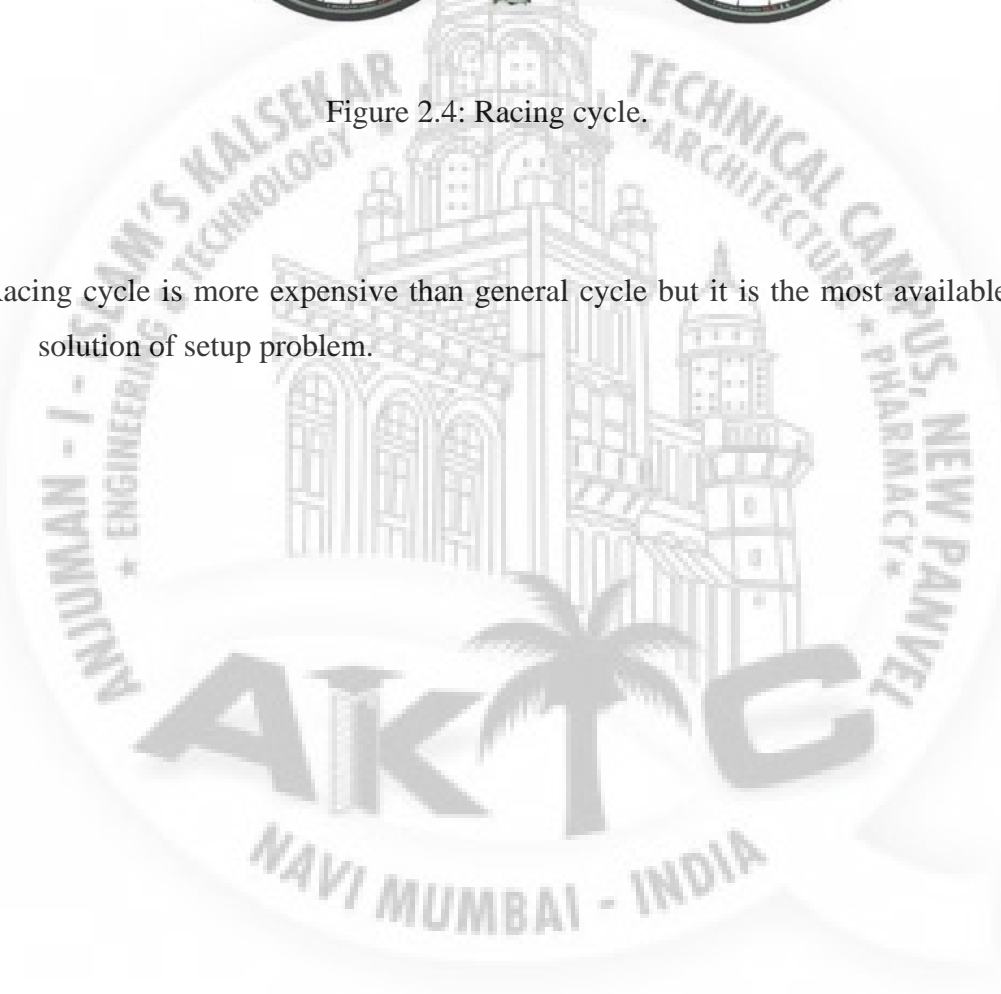



### 3. Description of Pedal Power Generator

#### 3.1 Design steps

The project begins with a simple approach embedded with very shallow theoretical knowledge. Elementary planning was formulated roughly conceiving general guideline given by the supervisor. The typical trial and error method was very fruitful to reach new designs, adopting one idea to another. The chronology of the preliminary designs and ideas are imprinted sequentially in upcoming paragraphs.

At first, very simple design was developed. This was not stable as well as quite complicated to materialize in the practical functioning shape.

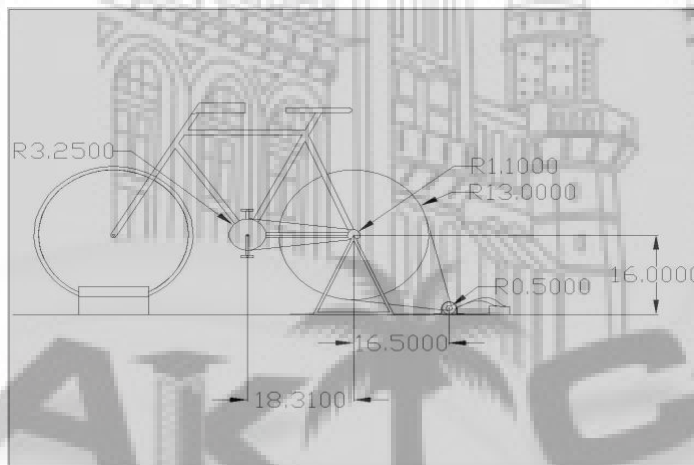

Figure 3.1: Initial design of pedal powered generator

Basing upon the previous experiences another attempt was launched. reinnovated design seemed stable including avisualization of lot of difficulties rised in the power transmission system.

Adjustable frame revealed another challenge predicting practical considerations.



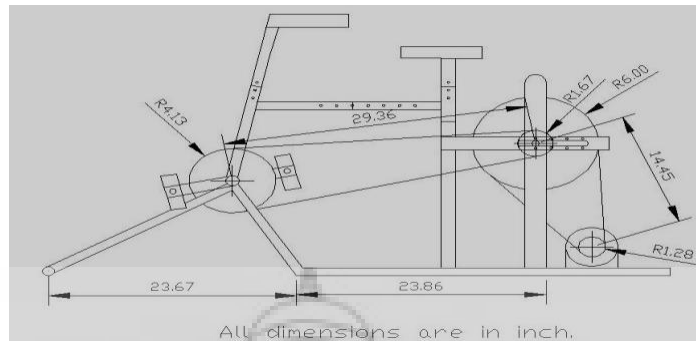

Figure 3.2 : Modified design of the setup

The next design exposed the accessibility of the first two design. A frame with the racing bicycle is used to eliminate the transmission problem . An external welded base is joined with the bicycle frame for stability.

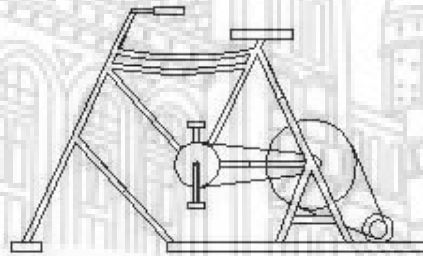

Figure 3.3: Approved design of pedal powered generator

This design was finally selected for this project.

### 3.2 Major components

- A bicycle structure with its front wheel removed.
- An automotive alternator.
- A belt pulley system for speed transmission.
- A regulator system for the alternator.

- An indicator system.
- An automotive battery.

### 3.3 Working principle

The entire setup works in three steps.

First, human energy is transformed into mechanical energy by means of pedaling. This Mechanical energy is represented in the form of rotation of chain sprocket system.

Second, the mechanical energy in the form of rotation is converted to electrical energy by the alternator which is connected to the chain-sprocket and belt-pulley system transmission system by means of pulley.

At the third stage the electrical energy is converted to chemical energy in the batter for future use.



Figure 3.4 Pedal Power Generator setup

#### 3.3.1 Production of mechanical energy

The bottom frame of the Pedal Generator was welded steel plate and channel, the crankset was an American Schwinn ball bearing set, a cotterless crank conversion spindle, alloy cranks and inexpensive pedals with toe clips.

The crankset had a steel chain-wheel on it. Some larger holes were drilled in the chain-wheel and bolted the particle board disk to it. It is strong enough to hold the weight of the particle board disk and run true. An oblong hole is routed through the particle board disk for the "arm" of the crankset.

The seat-post and handlebar tube were standard galvanized water pipe. The generator/motor was mounted on a piece of 3/4 plywood visible in the motor pictures seen above, which was then bolted to the water-pipe frame.

The particle board disk was a key feature of this unit. The weight of the disk served as an excellent flywheel. Human legs and pedals create an extremely "peaky" torque curve, resulting in jerky motion and lots of stress on parts. The flywheel smooths this all out by absorbing part of the energy on the power stroke, lowering peak torque, and releasing it on the "dead" part of the stroke, creating torque where Human legs/pedals cannot generate any. Another thing to remember is that Human legs do not like extreme stress. The flywheel allows the Human to avoid having to generate extreme pressure during the power stroke just to make it past the "dead" spots. Many "bicycle converters" lack the flywheel characteristic because tires/rims are designed to be so light.

Best output can be 25 amps at 17 volts (425 Watts) at 25 years old, and 265 Watts at 52 years old.

and 301 Watts at 55 years old.

### **3.3.2 Conversion of mechanical energy to electrical energy**

This is done by the alternator. Alternator is a type of generator. It has a unique feature to control its output voltage by a circuit called the regulator. The main components of an alternator are:

1. A stator in star or delta connection.
2. A single phase rotor with slip ring attachment
3. Two rectifier bridges.

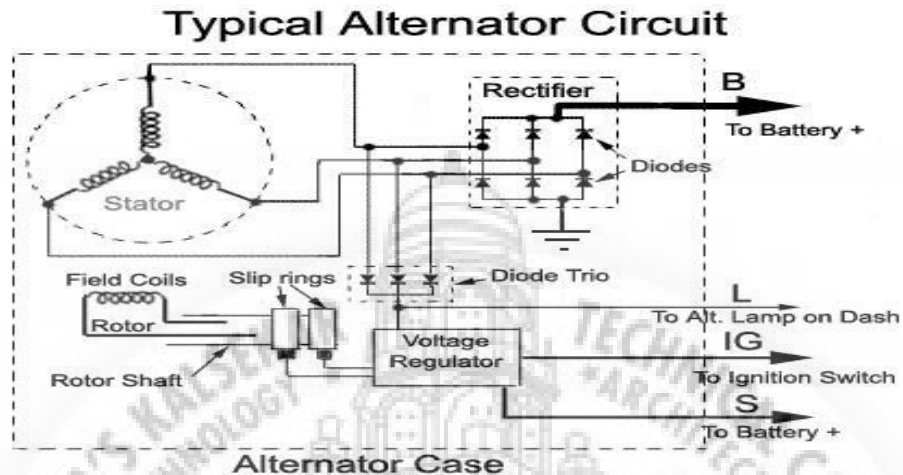

Figure 3.5: Typical Alternator Circuit

Another feature of the alternator is that it draws energy from the battery it is charging.

An automotive alternator is a three phase generator with a built in rectifier circuit consisting of six diodes. As the pulley is rotated by a belt connected to the automobile engines, a magnet is spun past a stationary set of three phase stator. The magnet is an electro magnet. Alternators are designed this way so that the magnetic field strength can be controlled, in order that the output voltage may be controlled independent of rotor speed. This rotor coil or field coil is energized by battery power, so that it takes a small amount of power as input to give large amount of electrical power as output.

Electrical power is conducted to the rotating field coil through a pair of copper slip rings mounted concentrically on the shaft connected by a stationary carbon brushes held firmly by springs. Many modern alternators are equipped with built in regulator.

### 3.3.3 Conversion of electrical energy to chemical energy for storage

Storage and discharge occurs in a battery by the following chemical reaction.

Discharge



□

Charge

### 3.4 Power transmission

In this pedal powered generator power transmission occurs in two stages to attain a minimum effective speed of 1000-1100 rpm. The first transmission occurs by a chain sprocket system and then a belt pulley system which are connected by a single free rotating shaft

First when the user pedals the machine the large sprocket is rotated at a speed equal to the rotation of the pedal. This large Sprocket has 48 teeth. The large sprocket is connected by a chain with the small sprocket of 18 teeth.

Let the large sprocket rotates at a speed  $N_1$  and the small sprocket rotates at a speed  $N_2$ .

So the relation of the rotation of the two sprockets is

$$\frac{N_2}{N_1} = \frac{48}{18} \quad (1)$$

Now the small sprocket has the same shaft with the large pulley of the belt pulley system.

So the large pulley rotates at the same speed as the small sprocket. So if the speed of the large pulley is

$N_3$  then

$$N_2 = N_3 \quad (2)$$

Here diameter of the large pulley is 30.48 cm and small pulley is 6.5 cm and let the speed of the small pulley is  $N_4$ . So

$$N_4 = 30.48$$

$$\frac{N_3}{N_2} = \frac{6.5}{6.5} \dots\dots\dots (3)$$

Now as the small pulley is coupled with the alternator so the speed of the small pulley will ultimately be the speed of the alternator.

Form equation 1, 2 and 3 speed of the alternator

$$\frac{N_4}{N_1} = \frac{48}{18} \times \frac{30.48}{6.5} = 12.505$$

So, the ultimate speed multiplying factor = 12.505

### 3.5 Calculation of Belt-Pulley selection

Let,

Diameter of Larger pulley,  $d_1 = 32$  cm

Diameter of small pulley,  $d_2 = 8$  cm

Centre distant between two pulley,  $c = 34.5$  cm

$$\frac{\pi}{2} (d_1 + d_2) + \frac{(d_1 - d_2)^2}{4c}$$

Then, length of the belt,  $L =$

$$\frac{\pi}{2} (d_1 + d_2) + \frac{(d_1 - d_2)^2}{4c}$$

$$= (32+8) + 2 \times 34.5 + \frac{(32-8)^2}{4 \times 34.5}$$

$4 \times 34.5$

$$= 136 \text{ cm}$$

Assume,

$$\text{Max power transmitted} = 300 \text{ Watt} = .3 \text{ KW}$$

From Machine Design hand book, table 17.16

For small driving and driven machine

$$\text{Service Factor } N_{sf} = 1.1$$

From Machine Design hand book, Equation (33)

$$\text{Design Power} = \text{Transmitted power} \times N_{sf}$$

$$= 300 \times 1.1$$

$$= 330 \text{ Watt}$$

$$\text{Centre to centre distance, } c = 34.5 \text{ cm} \quad [\text{Recommended Range } d_1 < c < (d_1 + d_2)]$$

$$= 345 \text{ mm}$$

Minimum Rotational speed of small pulley  $n = 1000 \text{ rpm}$

From Machine Design hand book, figure 17.6,

Belt section: A-section

For, A-section belt, minimum small pulley diameter  $d_2 (\text{min}) = 76 \text{ mm}$

From Machine Design hand book table 17.15

$$a = 0.4560$$

$$c = 19.8628$$

$$-4$$

$$e = .7736 \times 10$$

$$\pi \times d_2 \times n$$

Peripheral velocity of small pulley,  $v =$  \_\_\_\_\_

60

$$= \frac{\pi \times .08 \times 1000}{60} = 4.20 \text{ m/sec}$$

From Machine Design hand book

Table 17.7  $d_1/d_2 = 4.0$

then,  $K_d = 1.12$

From Machine Design hand book equation (30)

$$\text{Rated Power, } H_r = aV - \frac{0.91 cV^3}{Kdd1} - eV$$

$$= (0.4560 \times 4.2^3) - \frac{19.8628 \times 4.2}{1.12 \times 80} - (.7736 \times 10^{-4} \times 4.2^3)$$

$$= .744 \text{ KW}$$

From Machine Design hand book figure 17.8

$$\frac{d^1 - d^2}{32 - 8}$$

$$= 0.696 - c 34.5$$

then,

$$K_\theta = 0.84$$

$$\frac{(d_1 - d_2)^2}{4c}$$

$$\text{Belt Length} = 12c + 1.57 (d_1 - d_2) + \frac{(d_1 - d_2)^2}{4c}$$

$$= 135.0 \text{ cm}$$

Therefore,  $K_L = 0.95$



From Machine Design hand book equation (34)

$$\text{Adjusted rated power} = K_0 \times K_L \times \text{Rated Power}$$

$$= 0.84 \times .95 \times .744 \text{ KW}$$

$$= 0.59 \text{ KW}$$

*DesignPower*

No of Belt = \_\_\_\_\_

*AdjustedRatedPower*

$$= \frac{0.33}{0.59} =$$

$$0.56 \approx 1$$

From Machine Design hand book table 17.15

$$\text{Pitch length} = 1328 \text{ mm}$$

Belt-Pulley Specification

1. Belt No: A 51
2. No of Belt = 1
3. Diameter of Larger Pulley = 320 mm
4. Diameter of small pulley = 80 mm
5. Centre Distant = 34.5 cm
6. Belt Length = 1328 mm

### 3.6 Electrical circuit connection diagram

In a power production circuit, storage equipment (battery) is connected with different indicating devices and generator.

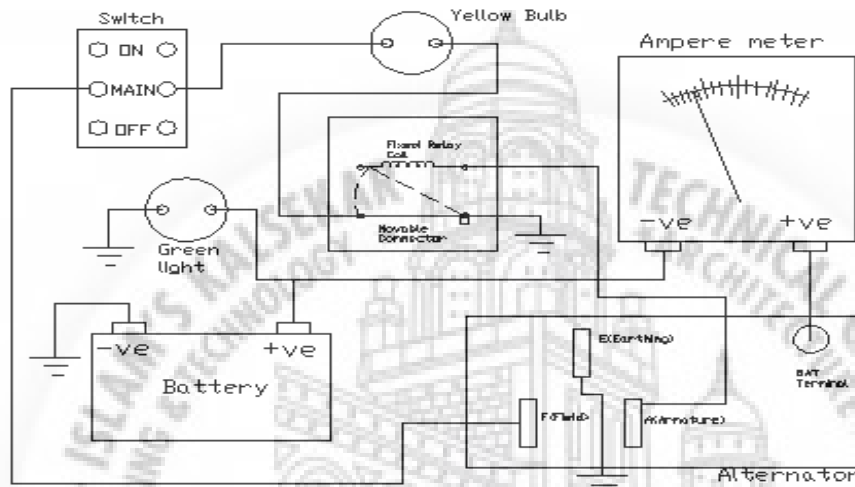
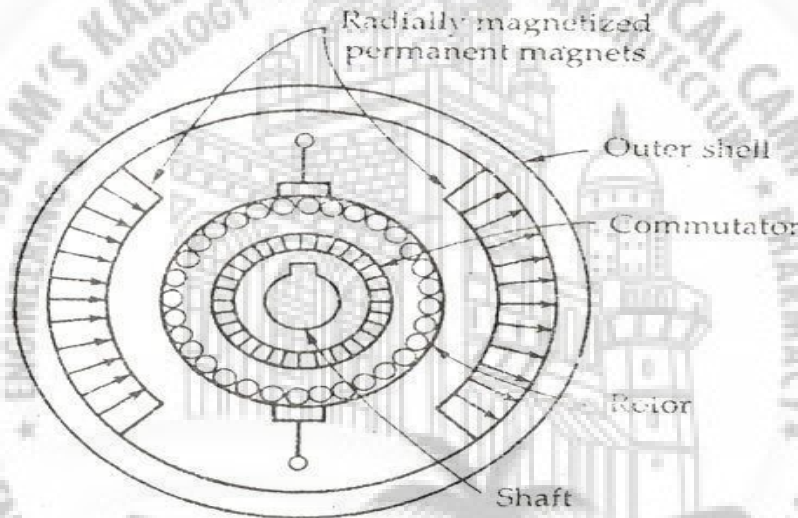

Figure 3.6: Electrical Circuit Diagram

## 4. Permanent Magnet DC Motor

A DC Motor whose poles are made of Permanent Magnets is known as **Permanent Magnet DC (PMDC) Motor**. The magnets are radially magnetized and are mounted on the inner periphery of the cylindrical steel stator. The stator of the motor serves as a return path for the magnetic flux. The rotor has a DC armature, with commutator segments and brushes.

The cross-sectional view of the 2 pole PMDC motor is shown in the figure below.



The Permanent Magnet DC motor generally operates on 6 V, 12 V or 24 Volts DC supply obtained from the batteries or rectifiers. The interaction between the axial current carrying rotor conductors and the magnetic flux produced by the permanent magnet results in the generation of the torque.

The circuit diagram of the PMDC is shown below.

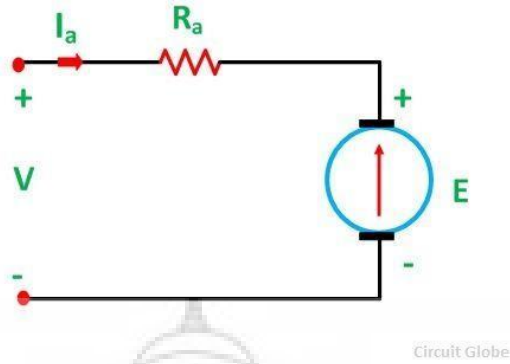

In conventional DC motor, the generated or back EMF is given by the equation shown below.

$$E = k \phi N \dots \dots \dots (1)$$

The electromagnetic torque is given as

$$\tau_e = k \phi I_a \dots \dots \dots (2)$$

In Permanent Magnet DC motor, the value of flux  $\phi$  is constant. Therefore, the above equation

(1) and (2) becomes

$$E = k_1 N \dots \dots \dots (3)$$

$$\tau_e = k_1 I_a \dots \dots \dots (4)$$

Considering the above circuit diagram the following equations are expressed.

$$V = E + I_a R_a \dots \dots \dots (5)$$

Putting the value of E from the equation (3) in equation (5) we get

$$V = k_1 N + I_a R_a \quad \text{or}$$

$$N = \frac{V - I_a R_a}{k_1} \dots \dots \dots (6)$$

Where  $k_1 = k \phi$  and is known as speed-voltage constant or torque constant. Its value depends upon the number of field poles and armature conductors.

The speed control of the PMDC motor cannot be controlled by using flux control method as the flux remains constant in this type of motor. Both speed and torque can be controlled by armature voltage control, armature rheostat control, and chopper control methods. These motors are used where the motor speed below the base speed is required as they cannot be operated above the base speed.

#### 4.1 Types of Permanent Magnet Materials

There are three types of Permanent Magnet Materials used in PMDC Motor. The detailed information is given below.

##### Alnicos

Alnicos has a low coercive magnetizing intensity and high residual flux density. Hence, it is used where low current and high voltage is required.

##### Ferrites

They are used in cost sensitive applications such as Air conditioners, compressors, and refrigerators.

##### Rare earths

Rare earth magnets are made of Samarium cobalt, neodymium-iron-boron. They have a high residual flux and high coercive magnetizing intensity. The rare earth magnets are exempted from demagnetizing problems due to armature reaction. It is an expensive material.

The Neodymium iron boron is cheaper as compared to Samarium cobalt. But it can withstand higher temperature. Rare earth magnets are used for size-sensitive

applications. They are used in automobiles, servo industrial drives and in large industrial motors.

## 4.2 Applications of the Permanent Magnet DC Motor

The PMDC motors are used in various applications ranging from fractions to several horsepower. They are developed up to about 200 kW for use in various industries. The following applications are given below.

- PMDC motors are mainly used in automobiles to operate windshield wipers and washers, to raise the lower windows, to drive blowers for heaters and air conditioners etc.
- They are also used in computer drives.
- These types of motors are also used in toy industries.
- PMDC motors are used in electric toothbrushes, portable vacuum cleaners, food mixers.
- Used in a portable electric tool such as drilling machines, hedge trimmers etc.

## 4.3 Advantages of the Permanent Magnet DC Motor

Following are the advantages of the PMDC

- Motor.
- They are smaller in size.
  - For smaller rating Permanent Magnet reduces the manufacturing cost and thus PMDC motor are cheaper.
  - As these motors do not require field windings, they do not have field circuit copper losses. This increases their efficiency.

## 4.4 Disadvantages of the Permanent Magnet DC Motor

The disadvantages of the PMDC motor are given below.

- Permanent magnets cannot produce a high flux density as that as an externally supplied shunt field does. Therefore, a PMDC motor has a lower induced torque per ampere turns of armature current than a shunt motor of the same rating.

- There is a risk of demagnetization of the poles which may be caused by large armature currents. Demagnetization can also occur due to excessive heating and also when the motor is overloaded for a long period of time.
- The magnetic field of PMDC motor is present at all time, even when the motor is not being used.
- Extra ampere turns cannot be added to reduce the armature reaction.



## 5. Bicycle and load

### 5.1 The Bicycle

A bicycle, also known as a bike, pushbike or cycle, is a human-powered, pedal-driven, single-track vehicle, having two wheels attached to a frame, one behind the other. A person who rides a bicycle is called a cyclist, or bicyclist.

Bicycles were introduced in the 19th century and now number about one billion worldwide, twice as many as automobiles. They are the principal means of transportation in many regions. They also provide a popular form of recreation, and have been adapted for such uses as children's toys, adult fitness, military and police applications, courier services and bicycle racing.

The basic shape and configuration of a typical upright bicycle has changed little since the first chain-driven model was developed around 1885. However, many details have been improved, especially since the advent of modern materials and computer-aided design. These have allowed for a proliferation of specialized designs for particular types of cycling.





Figure 5.1 Different parts of the bicycle

The invention of the bicycle has had an enormous impact on society, both in terms of culture and of advancing modern industrial methods. Several components that eventually played a key role in the development of the automobile were originally invented for the bicycle, including ball bearings, pneumatic tires, chain-driven sprockets, and spoke-tensioned wheels[44]. The bicycle consists of many components.

### 5.1.1 The Frame

The great majority of today's bicycles have a frame with upright seating which looks much like the first chain-driven bike. Such upright bicycles almost always feature the diamond frame, a truss consisting of two triangles: the front triangle and the rear triangle. The front triangle consists of the head tube, top tube, down tube and seat tube. The head tube contains the headset, the set of bearings that allows the fork to turn smoothly for steering and balance. The top tube connects the head tube to the seat tube at the top, and the down tube connects the head tube to the bottom bracket. The rear triangle consists of the seat tube and paired chain stays and seat stays. The chain stays run parallel to the chain, connecting the bottom bracket to the rear fork ends. The seat stays connect the top of the seat tube (at or near the same point as the top tube) to the rear fork ends.

### 5.1.2 Drivetrain and gearing

The drivetrain begins with pedals which rotate the cranks, which are held in axis by the bottom bracket. Most bicycles use a chain to transmit power to the rear wheel. A relatively small number of bicycles use a shaft drive to transmit power. A very small number of bicycles (mainly singlespeed bicycles intended for short-distance commuting) use a belt drive as an oil-free way of transmitting power.

Since cyclists' legs are most efficient over a narrow range of pedaling speeds (cadence), a variable gear ratio helps a cyclist to maintain an optimum pedaling speed while covering varied terrain. As a first approximation, utility bicycles often use a hub gear with a small number (3 to 8) of widely spaced gears, road bicycles and racing bicycles use derailleur gears with a moderate number (10 to 22) of closely spaced gear

ratios, while mountain bicycles, hybrid bicycles, and touring bicycles use dérailleur gears with a larger number (15 to 33) of moderately spaced gear ratios, often including an extremely low gear ("granny gear") for climbing steep hills.

### **5.1.3 Steering and Seating**

The handlebars turn the fork and the front wheel via the stem, which rotates within the headset. Three styles of handlebar are common. Upright handlebars, the norm in Europe and elsewhere until the 1970s, curve gently back toward the rider, offering a natural grip and comfortable upright position. Drop handlebars "drop" as they curve forward and down, offering the cyclist best braking power from a more aerodynamic "crouched" position, as well as more upright positions in which the hands grip the brake lever mounts, the forward curves, or the upper flat sections for increasingly upright postures. Mountain bikes generally feature a 'straight handlebar' or 'riser bar' with varying degrees of sweep backwards and centimeters rise upwards, as well as wider widths which can provide better handling due to increased leverage against the wheel.

### **5.1.4 Brakes**

Modern bicycle brakes may be: rim brakes, in which friction pads are compressed against the wheel rims; internal hub brakes, in which the friction pads are contained within the wheel hubs; or disc brakes, with a separate rotor for braking. Disc brakes are more common for off-road bicycles, tandems and recumbent bicycles than on road-specific bicycles.

## **5.2 Loads**

Many loads can be fitted in the pedal powered generator. The load application depends on the power of battery and power of the user.

### **5.2.1 Fluorescent Bulb**

A fluorescent lamp or fluorescent tube is a gas-discharge lamp that uses electricity to excite mercury vapor. The excited mercury atoms produce short-wave ultraviolet light that then causes a phosphor to fluoresce, producing visible light. A fluorescent lamp converts electrical power into useful light more efficiently than an incandescent lamp.

Lower energy cost typically offsets the higher initial cost of the lamp. The lamp fixture is more costly because it requires a ballast to regulate the current through the lamp.

While larger fluorescent lamps have been mostly used in commercial or institutional buildings, the compact fluorescent lamp is now available in the same popular sizes as incandescent and is used as an energy-saving alternative in homes.

The United States Environmental Protection Agency classifies fluorescent lamps as hazardous waste, and recommends that they be segregated from general waste for recycling or safe disposal

### **5.2.2 Fan**

A fan consists of a rotating arrangement of vanes or blades which act on the air. Usually, it is contained within some form of housing or case. This may direct the airflow or increase safety by preventing objects from contacting the fan blades. Most fans are powered by electric motors, but other sources of power may be used, including hydraulic motors and internal combustion engines and solar power.

Fans produce air flows with high volume and low pressure, as opposed to compressors which produce high pressures at a comparatively low volume. A fan blade will often rotate when exposed to an air stream, and devices that take advantage of this, such as anemometers and wind turbines, often have designs similar to that of a fan.

## 6. Discussion

### 6.1 Outcome of the project

The main outcome of this project is to produce electricity and to charge a battery successfully. But, during the work, many things are found that were not expected at the very beginning. They are:

1. A very complicated way was thought to establish the project. But at last, a readymade racing cycle was used for the setup. It provides the solution of many problems such as getting high speed at less time. Though multiple gear is used, but, user feels comfortable in the first gear.
2. Large scale production can be possible by using larger battery and more than one alternator. Electricity production depends on the number of users. If two setups operate at a time the production will be two times.
3. Some performance test was done. The idea about efficiency can be assumed by those data.
4. Production of electricity mainly depends on the rotor speed.
5. Charging time depends on the battery size and user's ability.
6. Most of the time result follow standard one but except sometimes they fluctuated.

### 6.2 Limitations

This project is not a perfect one. It has some limitations. They are:

1. Alternator rotates at the same speed of engine. Engine speed is 1100-1400 RPM which is very difficult to reach by pedaling. But, even more difficult task is to maintain this high speed all the time.

2. Alternator needs an initial power source to excite its own magnetic field. Battery works here as an initial power source and storage equipment. As a result alternator takes time to give output and cannot work without battery.
3. This setup will stop production for any kind of interruption of current in the alternator magnetic field. So, we cannot get any kind of electricity even a very high speed without current in the existing field.
4. Stable position of the alternator is very necessary for proper output.
5. No safety device such as voltage regulator cut out is used in this setup it can make the whole setup slow and costly.
6. Some experiments are done to evaluate the performance of the generator. Most results are satisfactory but in some cases it varies unexpectedly with the standard one the main reason is the precision on the measuring instrument because different data are found at same position in different time. Specially the hydrometer we used not an precise equipment.  
Addition to this, we lost some acid water mixture which produced wrong data.
7. A brand new component give always give better performance. The main component of this setup is the alternator but brand new alternator costs 5 times greater than the second hand. So, we could not use brand new equipment.
8. Battery specification is very important. Charging time mainly depends on the battery size.  
Large battery needs more human power and time.
9. To transmit power, a V-belt is used. Rope wire chain is not suitable for this purpose because of gripping ability and noise creation. But, these are stronger and more sustainable.
10. General bicycle is not perfect for this arrangement. Racing cycle or cycle with multiple geared cycles can produce high speed in less time. So, we used this but it increases the cost of the whole setup.

## 7. Conclusion and Recommendation

### 7.1 Introduction

The pedal powered generator is a very effective way to produce electricity in these times, when the problem of energy is rising. It is a very good solution of the shortage of energy. It can make a dramatic solution of the problem regarding power.

### 7.2 Further improvement

The performance of the machine can be further improved by taking the following steps:

1. A permanent magnet generator is a better option than AC alternator. It requires only the rotation of the rotor, no extra power for the magnetic field. It can also provide instant power supply. But, It is rare now a days and one time use.
2. Flywheel is the simple solution of maintaining uniform speed. But, balancing of a flywheel is a difficult task. So a heavy wheel can be used as a rear wheel of the cycle.
3. A larger wheel can provide greater speed to the rotor. At the same time, if smaller pulley is used in the alternator speed can be increased.
4. Permanent joint (welding, riveting) should be avoided for easy maintenance and transportation. It also gives opportunity to use the bicycle.
5. An adjustable cycle frame can be used so that people at different ages and sizes can pedal comfortably.

6. Power can be tremendously increased by connecting same arrangement in series. Rickshaw can be used instead of bicycle so that two rear wheels can take part in electricity production.



## REFERENCES

1. Harper, Douglas. "Energy". Online Etymology Dictionary. Retrieved May 1, 2007.
2. Retrieved on 2010-Dec-05". Faculty.clintoncc.suny.edu. Retrieved 2010-12-12.
3. Aitken, Donald W. (2010). Transitioning to a Renewable Energy Future, International Solar Energy Society, January, 54 pages.
4. HM Treasury (2006). Stern Review on the Economics of Climate Change, 575 pages.
5. World Energy Assessment (2001). Renewable energy technologies, p. 221.
6. REN21 (2011). "Renewables 2011: Global Status Report". p. 14.
7. Taylor, Thomas N; Taylor, Edith L; Krings, Michael (2009). Paleobotany: The biology and evolution of fossil plants. ISBN 9780123739728.
8. Tyler, S. A.; Barghoorn, E. S.; Barrett, L. P. (1957). "Anthracitic Coal from Precambrian Upper Huronian Black Shale of the Iron River District, Northern Michigan". Geological Society of America Bulletin 68 (10): 1293.  
doi:10.1130/0016-7606(1957)68[1293:ACFPUH]2.0.CO;2. ISSN 0016-7606.
9. Mancuso, J. J.; Seavoy, R. E. (1981). "Precambrian coal or anthraxolite; a source for graphite in high-grade schists and gneisses". Economic Geology 76 (4): 951–954.  
doi:10.2113/gsecongeo.76.4.951
10. The EIA reports the following emissions in million metric tons of carbon dioxide  
Nat gas: 5,840;



11. composition of natural gas". Naturalgas.org. Retrieved 2011-02-06.
12. US Geological Survey, Organic origins of petroleum.
13. Paul Mann, Lisa Gahagan, and Mark B. Gordon, "Tectonic setting of the world's giant oil and gas fields," in Michel T. Halbouty (ed.) Giant Oil and Gas Fields of the Decade, 1990-1999, Tulsa, Okla.: American Association of Petroleum Geologists, p.50, accessed 22 June 2009.
14. Dr. Irene Novaczek. "Canada's Fossil Fuel Dependency". Elements. Retrieved 2007-01-18.
15. Fossil fuel". EPA. Archived from the original on March 12, 2007. Retrieved 2007-01-18.
16. U.S. EIA International Energy Statistics". Retrieved 2010-01-12.
17. "International Energy Annual 2006". Retrieved 2009-02-08.
18. Smil (1991), p. 240
19. Natural Forcing of the Climate System". Intergovernmental Panel on Climate Change. Retrieved 2007-09-29.
20. World Wind Energy Report 2010" (PDF). Report. World Wind Energy Association. February 2011. Retrieved 8-August-2011.
21. Wind Power Increase in 2008 Exceeds 10-year Average Growth Rate". Worldwatch.org. Retrieved 2010-08-29.

22. Renewables 2011: Global Status Report". p. 11.
23. Kreis, Steven (2001). "The Origins of the Industrial Revolution in England". The history guide. Retrieved 19 June 2010.
24. Gwynn, Osian. "Dyfi Furnace". BBC Mid Wales History. BBC. Retrieved 19 June 2010.
25. Fridleifsson, Ingvar B.; Bertani, Ruggero; Huenges, Ernst; Lund, John W.; Ragnarsson, Arni; Rybach, Ladislaus (2008-02-11), O. Hohmeyer and T.
26. William E. Glassley. Geothermal Energy: Renewable Energy and the Environment CRC Press, 2010.
27. [www.wikipedia.org](http://www.wikipedia.org)
28. <http://www.los-gatos.ca.us/davidbu/pedgen.html>
29. Thompson, Sylvanus P., Dynamo-Electric Machinery, A Manual for Students of Electrotechnics, Part 1, Collier and Sons, New York, 1902
30. White, Thomas H., "Alternator-Transmitter Development.
31. Saadat, Hadi. 2004. Power Systems Analysis. 2nd Ed. McGraw Hill. International Edition.
32. Cyril W. Lander, Power Electronics third edition, McGraw Hill, 1993 ISBN 0-077077148 chapter 2 Rectifying Circuits.
33. Mansell, A.D.; Shen, J. (6 August 2002). "Pulse converters in traction applications".  
Power Engineering Journal.
34. "Battery" (def. 4b), Merriam-Webster Online Dictionary (2009). Retrieved 25 May 2009.

35. Power Shift: DFJ on the lookout for more power source investments. Draper Fisher Jurvetson. Retrieved 20 November 2005.
36. Buchmann, Isidor. Battery statistics. Battery University. Retrieved 11 August 2008.
37. "Spotlight on Photovoltaics & Fuel Cells: A Web-based Study & Comparison" . pp. 1–2.  
Retrieved 2007-03-14.
38. <http://van.physics.illinois.edu/qa/listing.php?id=563>
39. [http://www.allaboutcircuits.com/vol\\_1/chpt\\_11/2.html](http://www.allaboutcircuits.com/vol_1/chpt_11/2.html)
40. <http://www.azsolarcenter.org/images/docs/tech-science/papers/batteries/ch3.pdf>
41. All About Cycling, Rand McNally.
42. Richard Ballantine, Richard's Bicycle Book, Pan, 1975.
43. Caunter C. F. The History and Development of Cycles Science Museum London 1972.
44. David B. Perry, Bike Cult: the Ultimate Guide to Human-powered Vehicles, Four Walls Eight Windows, 1995.
45. [www.epa.gov/waste/hazard/wastetypes/universal/lamps/index.htm](http://www.epa.gov/waste/hazard/wastetypes/universal/lamps/index.htm)