

Project I

"Automatic segregation and supervision of waste material using Industrial Control Devices"

Submitted in partial fulfilment of the requirements for the degree of
Bachelor of Engineering

by

Khan Salman Roll No. 17DET46

Shaikh Faraz Roll No. 17DET62

Khan Athar Roll No. 17DET43

Ansari Afwan Roll No. 17DET40

Supervisor

Asst. Prof. Awab Fakh

**Department of Electronics and Telecommunication
Engineering,**

School of Engineering and Technology

Anjuman-I-Islam's Kalsekar Technical Campus

Plot No. 23, Sector -16, Near Thana Naka, Khanda Gaon,
New Panvel, Navi Mumbai. 410206

Academic Year : 2019-2020

CERTIFICATE



Department of of Electronics and Telecommunication Engineering,

School of Engineering and Technology,
Anjuman-I-Islam's Kalsekar Technical Campus
Khanda Gaon, New Panvel, Navi Mumbai. 410206

This is to certify that the project entitled *Automatic Segregation and Supervision of Waste Material using Industrial Control Devices* is a bonafide work of **Khan Salman (17DET46), Shaikh Faraz (17DET62), Khan Athar (17DET43), Ansari Afwan (17DET40)** submitted to the University of Mumbai in partial fulfillment of the requirement for the award of the degree of **Bachelor of Engineering in Department of Electronics and Telecommunication Engineering.**

Asst. Prof. Awab Fakh

Supervisor

Asst. Prof. Afzal Shaikh

I/c HoD,ET

Asst. Prof. Siraj Pathan

Project Coordinator

Dr. Abdul Raza Honnutagi

Director

Project I Approval for Bachelor of Engineering

This project entitled *Automatic Segregation and Supervision of Waste Material using Industrial Control Devices* by *Khan Salman (17DET46), Shaikh Faraz (17DET62), Khan Athar (17DET43), Ansari Afwan (17DET40)* is approved for the degree of *Bachelor of Engineering in Department of Electronics and Telecommunication Engineering*.

Examiners

1.

Supervisors

1.



Declaration

I declare that this written submission represents my ideas in my own words and where others ideas or words have been included, I have adequately cited and referenced the original sources. I also declare that I have adhered to all principles of academic honesty and integrity and have not misrepresented or fabricated or falsified any idea/data/fact/source in my submission. I understand that any violation of the above will be cause for disciplinary action by the Institute and can also evoke penal action from the sources which have thus not been properly cited or from whom proper permission has not been taken when needed.



Khan Salman Mehtabali
17DET46

Shaikh Faraz Riyaz
17DET62

Khan Athar Wasi Ahmed
17DET43

Ansari Afwan Kamruddin
17DET40

Acknowledgement

It is our great pleasure to present this report, a written testimonial of a fruitful experience. It would be unethical on my part to claim complete credit for the project. We therefore take this opportunity to express acknowledgement to all those individuals who helped in making our project a success.

We are highly indebted to Asst. Prof. Awab Faikh for guidance and constant supervision as well as for providing necessary information regarding the project. We would also like to thank Prof. Afzal Shaikh (HOD-Electronics Telecommunication Department) working with whom is a delightful and wholesome learning experience. We would like to express my sincere gratitude towards Mr. Momin Shoeb (Sr.Engineer-Pinnacle Industrial Controls Pvt.Ltd.) and Mr. Alister DSilva (Director-Absolute Motion Pvt.Ltd.)for offering us an internship and allowed to gain industrial exposure through it.

We would also like to thank Prof. Siraj Pathan and other faculty for their remarks and suggestions during progress of the project work. They have given us the direction and has made us understand the project better.

Our sincere thanks to teaching non-teaching staff without whom this wouldn't have been possible. We will be grateful for their guidance, support and help whenever we needed it. Our thanks and appreciations also go to my colleague in developing the project and my friends who have willingly helped me out with their abilities.

Contents

Project I Approval for Bachelor of Engineering	ii
Declaration	iii
Table of Contents	vi
List of Figures	vii
1 Introduction	1
1.1 Introduction	1
1.2 Statement of project	2
1.2.1 Project Architecture	2
1.3 Motivation: -	3
2 Literature Review	4
2.1 RFID Based Segregation System.....	4
2.2 Micro-Controller Based Automatic Waste Segregation.....	5
2.2.1 Open close mechanism:-	5
2.2.2 Inductive Proximity Sensor:-	5
2.2.3 Conveyor Belt Mechanism:-.....	6
2.2.4 Blower Section:-	6
2.2.5 Ultrasonic Sensor Section.....	6
2.3 Software Implementation: -.....	6
2.4 Drawbacks or Weakness of the System.....	6
2.5 How to Overcome: -.....	6
3 Technical Details	8
3.1 Technical Skills Requirement.....	8
3.2 Methodology: -.....	8
3.3 Project Requirement.....	8
3.3.1 Software Requirements.....	9
3.3.2 Hardware Requirements.....	10
3.3.2.1 Crusher.....	10

3.3.2.2 Programmable Logic Controller (PLC).....	10
3.3.2.3 Sensors.....	13
3.3.2.4 Conveyor Belt and Fan.....	16
3.3.2.5 Hydraulics Cylinder.....	18
4 Ladder Logic Programing	20
4.1 Program of the System.....	20
4.2 Step of Writing and Executing of program Program.....	24
5 Result	30
6 Conclusion	31
7 Thesis Plagiarism Report	32
8 International Conference	36
8.1 Acceptance Letter.....	37
8.2 International Conference Paper Plagiarism Report.....	39
8.3 International Conference Paper Copyright.....	40
8.4 International Conference Paper Certificate.....	48
9 Internship	52
9.1 Internship offer letter of Salman.....	53
9.2 Internship offer letter of Athar.....	54
9.3 Internship offer letter of Faraz.....	55
10 References	59

List of Figures

1.1	Block Diagram of System.....	2
2.1	RFID Based Segregation System	4
2.2	PLC Based Segregation System	7
3.1	Communication Between PLC and Industrial Controls	9
3.2	SCADA	10
3.3	Major Component of a PLC	11
3.4	PLC System Diagram with Electric Symbol	13
3.5	IR Sensor	14
3.6	Moisture Sensor.....	15
3.7	Proximity Sensor.....	15
3.8	Plastic Detection Sensor	16
3.9	Glass and Paper Detector.....	16
3.10	Conveyor Belt.....	17
3.11	Conveyor Belt.....	18
3.12	Hydraulics Cylinder.....	19
4.1	Ladder Logic Program	20
4.2	Ladder Logic Program	21
4.3	Ladder Logic Program	22
4.4	New File Creation	24
4.5	Select Type of Language.....	25
4.6	Design Logic Program.....	26
4.7	Communication Setting.....	27
4.8	Run and Stop Logic Program.....	28
4.9	Upload and Download Logic Program.....	28
4.10	Online Mode.....	29
5.1	POW	30
6.1	HMI Display.....	31

Chapter 1

Introduction

1.1 Introduction

Lifestyle has become the biggest leisure of today's world and with growing lifestyle and ways of Living the amount of waste generated also goes high. To overcome today's mans needs various echnology and industrial setups have been made up. These industrial setups release huge amount of waste. Homes and other man habits also have equal contribution in increasing the waste content in this world. Now the question arises that what should be done for this? should it just be dumped somewhere or used again? as we know there is no waste that can be used again, once already used. but yes it can be recycled and used. but yes it can be recycled and used for other purposes?

Some wastes are biodegradable and get decayed on the soil, but other wastes like plastic, glass and metal does not decay or is not biodegradable in nature. As far as the waste is concerned, if it is not treated properly then severe harm is done to the environment which causes increase of harmful gases in nature. So far of these problems to be overcome different steps are been taken to ensure reduce the wastage and to recycle the waste created, the first prerequisite for waste management is separation of different materials so that they can be processed for different uses, at past times the waste was segregated by man himself, which ate up a lot of man power and time, but this was not the most efficient way to do it. As time passed away and working became fast with the rapid growth of man and technology, many such ways of separating the waste came into consideration. One such way this. way not the machines separate the waste. This can save a lot of time and man power. Our project focuses on particular aspects of making of time and man power. Our project focuses on this particular aspects of making one of the most tough jobs easy. As far as the separation is considered. Waste treatment is important but it is impossible to treat waste without separating it so this the one of the most important topic to focus on. Solid waste which behaves as the most important aspect to look on. It creates most of the hazards in our environment. With increase in pollution and global warming, untreated and unattended waste is one of the major reasons behind this. So treatment of this was one of the main issues. According to resources our country does not stand in one of the leading waste treatment country of this world where Germany stands on top for the waste management. As we see our country has a major amount of waste created, which is not attended and treated properly, so it is high time we start focusing on this.

Our project shows light on separating different items on the basis of the material they are made of. We use sensors and others industrial device to detect and sort out the waste as per our

requirements. The main Brain behind this or you can say the controller for this particular system is the PLC (Programmable Logic Controller). It is one of the most user friendly device to use for heavy duty applications and the ease of programming makes it more efficient to use it. This project is something which we want to use to help the society overcome and finish the problem of waste treatment and to give small amount of care to nature.

1.2 Statement of project

The Implementation of this project is to segregate Municipal Solid Waste (MSW) into bio-degradable and non-biodegradable waste with the help of Industrial control devices. The segregation of MSW is done automatically with minimum human intervention .

1.2.1 Project Architecture

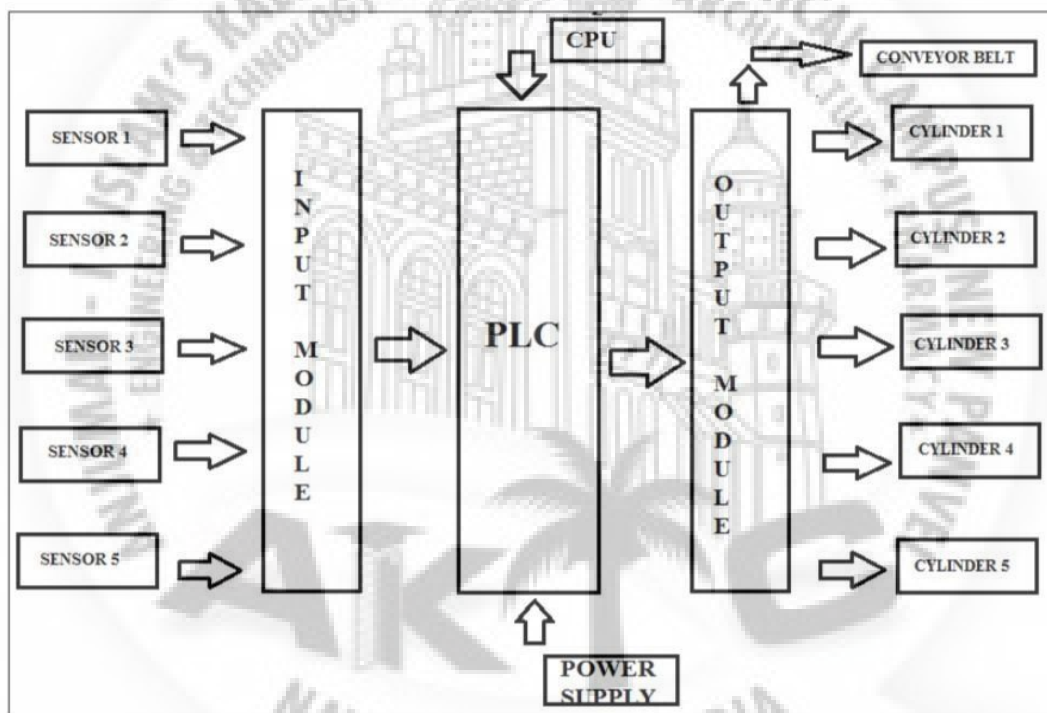

Figure 1.1: Block Diagram of System

[Link: <https://www.researchtrend.net/ijet/pdf/4920ICRIET-219.pdf>]

This system is a completely PLC based logic controlling system. There are several parts of this system which are to be focused. The sections consist of three parts i.e. the input side, the controller and the output side. Now there are different units of these section, as the first section of our input consists of several sensors used for sensing plastic, glass, metal and other wastes. A conveyor which starts as soon as the waste is detected. As the waste starts moving with the

conveyer, the blower starts which eliminates light weight garbage and dust particles and collects it separately. Next comes the programmable logic controller, which works on the program Chapter 1. Introduction

written in it. It senses the input section takes the signal and processes it as per the program installed. PLC is the efficient controller for such heavy duty systems and ease of programming makes it easy to work on. The third and the last section consists of the output devices that are the pneumatic hydraulic cylinders (CD- Drive) which sense the output given by the PLC and push ahead the flaps as per the signal provided to them. There are bins or we can say collectors that are placed as per the outputs decided in which all the waste is isolated and collected.

1.3 Motivation:-

When it comes to our comfortable zone we humans give our most to keep our lifestyle stable. same ways disturbing our environment can disturb the atmosphere and our living style so it becomes our duty to keep things around us proper. To acquire something is not difficult but to maintain it, is what it takes. This project focuses on making man realize what steps are to be taken to keep everything on path. Its high time we focus on our environment and realize that it is to be taken care if as we all know that precautions is better than cure. Working on the waste materials around us will accelerate many good things in the society like usage of biodegradable things and recycling of materials. If these things are practiced from now itself. Then this will be one of the gifts we would be giving to the upcoming generation and If not then even they will be neglecting this situation, resulting in failure of earth's ecosystem. Dumping and Burning being the only solution in today's world for waste this project puts light on another substitute method or main method to treat waste into useful staff.

Being one of the ways in making man's life easy. Automation has always provided solutions and leisure to our life. Using these same aspects or technology for helping us improve the surroundings. Applying today's fast technology in making life easy and helping the ecosystem is one of the main aims of this project. Building up a system to improve and helping man counter these problems of increase in waste and managing it. Waste has to be treated properly otherwise it harms our environment in all the ways it can. Neglecting this is one the things that we humans do. Generation of wastage has increased and management has decreased. Other part of this is that no one treats it as a serious problem. It is as necessary for us as all the other problems are. For upcoming generations when they will be facing more serious problems than us, so we need to work on this from now. So its hard time we start working on it and our system aims on the same. Using this project we aim to reduce 70-80 percent of municipal waste which is a huge figure to look on and work. Wishing everyone to encourage and get used to this system.

Chapter 2

Literature Review

2.1 RFID Based Segregation System

In this system Radio Frequency identification is used for online detection of consumer group. This system is accurate and not only accurate but also robust and also it can handle very large quantity of E-waste and plastic etc. In this system every waste, material will be identified their type of RFID tags. This tag stores the information of the material or product. This tags travels along the object on the conveyor belt. Whenever waste is near, RFID reads it and then sends all the information on that material or object the reader in soft command and information are exchange between the reader and RFID tags. This information helps to drop the object into respective bean. In this process Arduino microcontroller is used to segregate the waste. RFID send the information to the Arduino for further process between the receiver and the RFID. It will be forwarded to receiver to collect this information. Drawbacks: The main drawback of this system is, when the product is manufacture at that time RFID should be attended to it for just only to resolve the problem of separating materials. This method of segregation is too costly and time consuming. All the companies would add their cost of applying RFID so it is not valid. And we are using RFID for waste product, so to use RFID scanning like technology in such harsh and non-suitable condition is not suitable. Chapter 2. Literature Review



Figure 2.1: RFID Based Segregation System
[Link: <https://youtu.be/EnIkQnR3DDw>]

2.2 Micro-Controller Based Automatic Waste Segregation

In this system the micro-controller is the main component. The micro-controller controls the time and working of the hole system. This system sorts the waste in to only three categories such as dry and wet waste. The working of this system is divided into several sections as follows:

2.2.1 Open close mechanism: -

- Basically, this mechanism controls the waste the falls on the conveyor belt. A 12v DC motor is used to allow or to stop waste from falling on the conveyor belt. This motor is basically moved in clockwise or anti-clockwise direction to open and close the outlet of the funnel. This motor is controlled by the micro-controller. This mechanism is initiated only if the waste is detected by the IR sensor.

2.2.2 Inductive Proximity Sensor: -

- An inductive proximity sensor is used to detect the incoming waste is whether metallic or non-metallic. This sensor uses three proximity sensors, each of them are of 12v. The working of this sensor is in such a way that, when the sensor detects a metallic material then the output will be 1 and when the sensor detects a non-metallic material the output will be 0. The output of this is an input to micro-controller.

2.3. Software Implementation: -

2.2.3 Conveyor Belt Mechanism: -

- A 12v DC inductive motor is used to move the conveyor belt this motor is controlled by the micro-controller. As soon as the proximity sensor senses the object or a waste material the conveyor belt work according to it, the start and stop of the belt is controlled by relay. The relay basically makes and breaks the connection to start and stop the motor of the conveyor belt.

2.2.4 Blower Section: -

- The blower is placed along the conveyor belt, it basically used to separate the wet and dry material or waste. This blower is specially running on very high speed, as the dry and wet waste have the different density, the weight of the wet waste or material is high and dry material is light as compared to wet material. The blower simply blows away the light weight material but the wet material is heavy, it cannot be easily moved by the blower it will still remain on the conveyor belt and then drop to the respective bin.

2.2.5 Ultrasonic Sensor Section: -

- This section basically controls the blower. This sensor placed just before the blower. If this sensor detects any waste material, it turns ON the blower for a programmed time and then turn OFF. This will prevent the blower from being continuously ON.

2.3 Software Implementation: -

As the micro-controller is the programmable device. The programming is done order to work the controller according to the requirement. Generally, C-language is used for programming. Basically here Keil version 3 is used to program the micro-controller.

2.4 Drawbacks or Weakness of the System:

- The segregation of the waste material consumes the more time In this system.
- This system is not suitable in different types of environment.
- This process cannot be used for segregating the medical waste and e-waste as there are certain rules specialized by the government for their separations.
- The magnetic metals are attached to the permanent magnet that must be separated out manually from the metallic bin.
- This system cannot handle many different loads at a time
- This system is not suitable for all different types of temperature.
- In this system the size of waste must be less than or equal to the dimension of the funnel, here it is 20cm x 20cm.

2.5 How to Overcome: -

- To overcome this all drawbacks, A system is introduced which is based on Automation (PLC).
- This system is more accurate in all aspects.
- In this system microcontroller is replaced by the PLC. Basically it's a programmable logic control device.
- It has more inputs and outputs to the microcontroller.
- In this the size of a funnel or size of a waste material is not an issue.
- Inlet system can also be replaced by the crusher mechanism to reduce the size of waste material.
- The range of the inductive proximity sensor is more in PLC based system as compared to microcontroller based segregation.
- The system requires short term adjustment without having the large impact on the whole system.
- This system is more flexible compared to any other waste segregation systems.
- It consumes less wiring so the cost will be reduced.

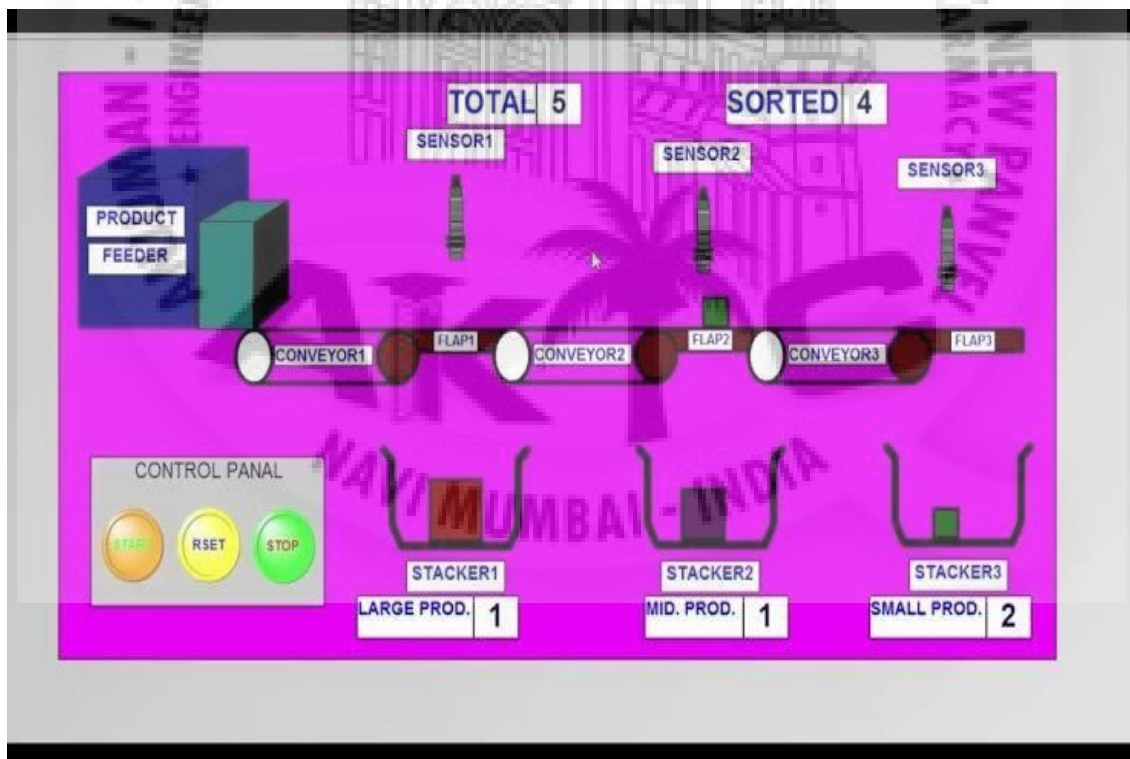

Figure 2.2: PLC Based Segregation System
 [Link: <https://youtu.be/eF-Lj4uwnlE>]

Chapter 3

Technical Details

3.1 Technical Skills Requirement

In this period, we started to know that what are the technologies or courses that are required to build this project. We started to learn those courses. Since automation is a huge field itself, so there are lot many courses that are used to build this project. So basically automation is to communicate software with hardware.

3.2 Methodology: -

Generally, this system operates on three main stages that is input module stage, output stage and the main PLC module stage. This stage is the heart of whole system. At this input stage, the sensor are interface with PLC, The detection of plastic dry and wet material glass mare done in this stage. The sensors are arranged along the long conveyor belt. This all are appropriate arranged with the respective hydraulics cylinders. And for each material collection different bins are placed below the conveyor belt. High speed blower is also connected to blow away dust particles and other light and dry weight materials in to a collector place exactly opposite to it. The second stage is the most important stage of the system it holds the system, it is brain of the system, i.e. PLC module stage. PLC is a programmable logic control device; it is a controller. It programs according the need of the user, the system operates according to the program installed in the PLC. Normally PLC is used in the Small-Scale industries, the sensors output accept by the PLC and according to that hydraulic cylinder operates. The third and the last stage is the output module stage. Inn our project hydraulic cylinder and conveyor belt is interfaced on output stage. As soon as IR sensor detect the object of waste material, the conveyor belt starts running and the cylinders are energized when the respective material object or waste is detected in order to push waste into respective bin.

3.3 Project Requirement

The main requirement of project is to communicate PLC with sensor, pneumatic system and conveyor belt. Secondly, we have to know how to program PLC and selection of PLC according to project requirement. Also, we have to study about industrial controls.

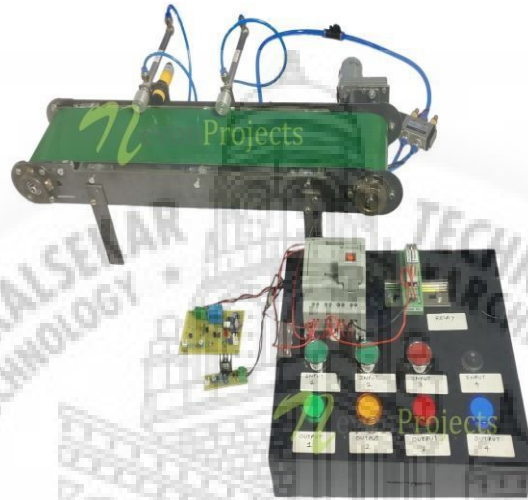

Figure3.1:CommunicationBetween PLC and Industrial Control

[Link: <https://nevonprojects.com/plc-based-sorting-system-using-metal-detection/>]

3.3.1 Software Requirement

As the PLC is a programmable device it requires a software at which the program can be create and installed in the PLC,. The five most popular programming technique to program a PLC are ladder diagram (LD) , sequential function charts (SFC) , function block diagram (FBD), structure text(ST) and instruction list(IL). Here we are using ladder diagram programming, and the software use to program Allen Bradley PLC is" RS Linux Classic". This software basically helps the user to communicate PLC with computer. RS Linux classic for Rockwell automation network and devices is an comprehensive factory communication solution, it provides Allen Bradley programmable controller access to a wide variety of Rockwell software. The easiest way to think about RS Linux classic is something like a communication central.

SCADA stands for supervisory control and data acquisition system. This system is used to monitor and control a plant or equipment in industries such as telecommunications, waste and waste control, gas and oil refining and transportation. SCADA is not a specialized technology but it is a type of application, any application that gets data about a system in order to control the system is a SCADA

and can be operate in any condition, a microcontroller comes in the existence, but it also have some disadvantage, the main disadvantage of microcontroller is its operation time. It requires more time to operate and also it cannot interface high power devices directly, it also perform limited number of execution simultaneously. so in order to overcome all this problem a new system is introduced, named as programmable logic controller [PLC].

A PLC is defined as “A digitally operating electronic apparatus which uses a programmable memory for the internal storage of instructions by implementing specific function such as logic sequencing, timing, counting, and arithmetic to control, through digital or analog input or output modules”. A programmable logic controller is basically a digital computer which is used for automation of electromechanical processes, such as controlling of machines on the factory assembly. The PLC is used to control the processes in industries. The PLC is designed for multiple input and multiple output arrangements, it can operate in extended temperature range, PLC cannot be affected by electrical noise, it also highly resistive to vibration and impact. The program to control any machine is stored in a nonvolatile memory. Programmable logic control is a real time controller which output results must be produced in response to input condition within a particular time limit.

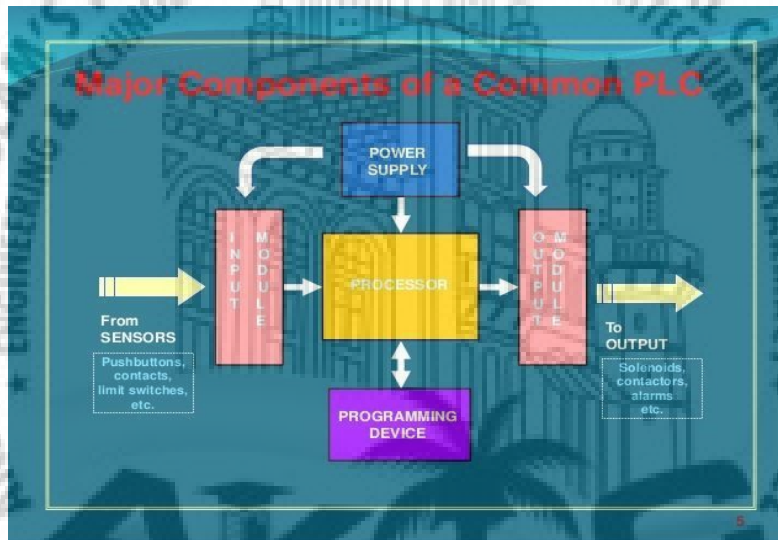

Figure 3.3: Major component of a PLC

There are four main units in PLC as shown in the above figure.

- 1] Programmable memory.
- 2] Data memory.
- 3] Output module.
- 4] Input module.

1] Programmable memory: - Basically it is a memory in which the program or logic instructions are stored. It is the random-access type memory; it can be volatile or nonvolatile and program can be rewritten often.

Chapter 3. Technical Details

2] Data memory: - It is also a random-access type memory, can be volatile or nonvolatile. The data memory stores the status of switches, it stores the past values of data and other values are also stored here.

3] Output device: - The output module focuses in converting control signal from the CPU in to digital or analog values which can be used to control various output devices. The devices at the output side can be solenoid, switches, motors, etc.

4] Input device: - The input module converts the sensor signal in to logical signal which can be used u by CPU of PLC, the input devices are hardware or software driver for industrial process sensors such as witch status sensors, proximity sensors, etc.

5] Working principle of PLC: - The programmable logic controller is used to continuously monitor the input values from the sensor or any device on the input and produces the outputs for the operation of actuators base on the program. Every programmable logic controller [plc] is comprises from these three modules:

- CPU module
- Power supply module
- One or more input/output module.

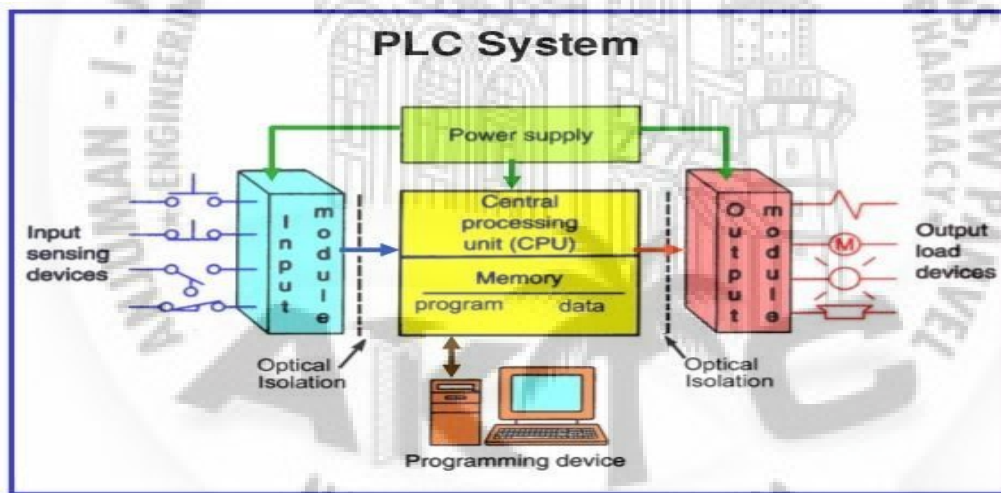

Lecture – Introduction to PLC's

MME 486 – Fall 2006

14 of 47

Figure 3.4: PLC System diagram with Electric Symbol

[Link: <https://image.slidesharecdn.com/introtoplcs-131229191401-phpapp02/95/introto-pl-cs-14-638.jpg?cb=1388344503>]

CPU module:-

CPU is termed as central processing unit. This module consists of processor and memories. The main function of CPU is to store and run the PLC soft wares. Basically, the processor is responsible for computing and processing the input data and produce the appropriate output according to the input.

Power supply module: -

This module is responsible for supplying the required power to the hole PLC according the CPU and I/O module, by converting the AC power to DC power. “5V DC drives the computer circuit”.

I/O module: -

- Input module: Input module detects the status of the input signal such as sensors which convert the physical energy in to electrical signal.
- Output module: An output module converts the control signal from to CPU in to digital or Analog values or signals which can be used to control various output devices.

3.3.2.3 Sensors: -

Basically, sensors are used to sense the different types of waste material, as the waste material are all different types there are different types of sensors used such as following:

- IR sensors: -

The main function of IR sensor is to detect the presence of the object on the conveyor belt. As the name indicates the IR sensor senses the object with the help of reflecting infra radiations on the object. In our system the presence of any object on conveyor, emitting the infra radiations. As soon as the object is detected t the sensor will signal the PLC to start or stop the belt. A separate switch is also used to turn ON and OFF the belt.



Figure 3.5: IR Sensor

[Link:<https://www.google.com/> <https://www.amazon.in/OLatus-01-Ir-Sensor-Readymade-Proximity-Detecting-Readymade/dp/B07D35X961>]

Chapter 3. Technical Details

- Moisture Sensors: -

This sensor basically detects the object that are having moisture molecule inside it or in similar way it detects the waste material. The sensor is used to sense the waste and organic waste material from dry waste. It is placed at the beginning of the long conveyor belt It measures the change in electrical impedance where the water vapor is absorbed, the ionic function get dissociate and the electrical conductivity will increase due to conductive polymer.

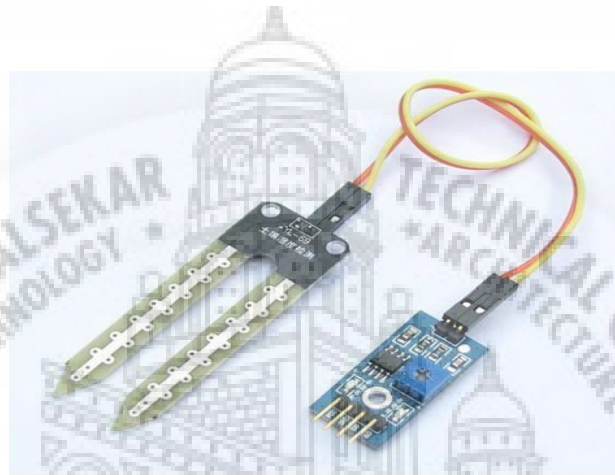

Figure 3.6: Moisture sensor.

[Link: <https://www.indiamart.com/proddetail/soil-moisture-sensor-12778810133.html>]

Metal Detection Sensor: -

As the name indicates it detects the metals from the waste. In our case we use proximity sensors. There are different types of proximity sensors used such as capacitive proximity sensor and inductive proximity sensor. This proximity sensors operates on the principles that the inductance of a coil and the power losses in the coil vary as a metallic or we can say conductive object is detected thus we use inductive proximity sensor to sense the metallic waste and is insensitive to non-metallic waste.

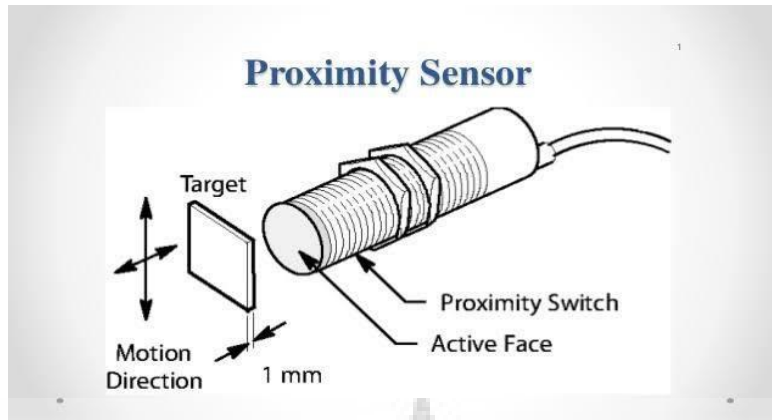

Figure 3.7: Proximity Sensor

[Link: <https://www.slideshare.net/arif0o7/proximity-sensor-42438958>]

- Plastic detection sensors: -
It basically detects all the plastic waste material; it uses a photo electric sensor built in amplifier for detection of plastic, bottles, etc. Different size of bottles can be separated using this sensor.



Figure 3.8: Plastic detection Sensor

[Link: https://www.alibaba.com/product-detail/40kh-Plastic-Material-16mm-ultrasonicsensor_60523308466.html]

Chapter 3. Technical Details

- Glass and Paper Detector: -
In this we use proximity sensors, there are two different type of proximity sensors i.e. inductive and capacitive proximity sensor. Inductive proximity sensor is used to detect the metallic waste and capacitive proximity sensors are used to detect the glass and paper waste. The working principles of this sensor are that, an internal oscillator will oscillate until a target material moved close in front of sensor face. Due to the interface of material the capacitance of a capacitor varies, that is the part of a oscillator circuit.



Figure 3.9: Glass and Paper Detector

[Link: https://www.alibaba.com/product-detail/40kh-glas-sand-paper-Material-16mmultrasonic-sensor_60523308466.html]

3.3.2.4 Conveyor Belt and Fan:-

In the manufacturing industries, heavy raw materials or products need to transport from one stage to another stage in order to complete the process or production, for transporting this materials heavy material handling equipment's are used, this material handling equipment's are designed such that they facilitate easily, cheap, fast and safe loading and unloading with very less human effort and interference. There are many different techniques used such as "fork lifting, use of bucket elevation, conveyors system, cranes, etc." this technique are used to transport bulk material or product from one place to another in the manufacturing industries.

So basically, material handling involves loading of material, movement of material, and unloading of material from one stage to another stage. A conveyor belt consists of an flexible belt which can be expand endless and can be placed in any position, this belts have an impressive strength and capacity to load a bulk product. The conveyor belt has two end pulleys at fixed position. These two ends are driver and driven which are supported by the roller or a motor. Pulleys are used to provide the drive belt through a unit gear box call driver unit gear box which is powered by an electric motor.it also helps in maintain the proper tension to the belt. The drive supplies the power to one or more pulleys to move the belt and the load on it. The materials are transfer from one placed to another place according to the required distance because of friction generated between the roller and the moving belt set in motion by a rotating pulley called driver pulley. The driven or ideal pulley is act as a wheel around which the product or material rotated and return back to its continuous process.



Figure 3.10: Conveyor belt

[Link: <https://nevonprojects.com/wp-content/uploads/2018/06/PLC-based-product-sorting-machine.jpg/>]

Chapter 3. Technical Details

The advantage of conveyor belt is that it is easy and cheap to maintain as well as install. It also have high loading and unloading capacity and can be transfer bulk load to long a distance.

In this project we are using conveyor belt system to segregate the different waste material in to the separate bin. Conveyor belt system is basically a mechanical system which can be controlled by using different technologies such as PLC, Microcontroller, Raspberry Pi, etc.

A 12V DC inductive motor is used to move the conveyor belt, this motor is controllable. In this project as soon as the proximity sensor sense the object or any waste material the conveyor will operate according to the PLC program, the start and stop of conveyor belt is controlled by relay. The function of this really is to make and break the connection to start and stop the motor of conveyor belt.

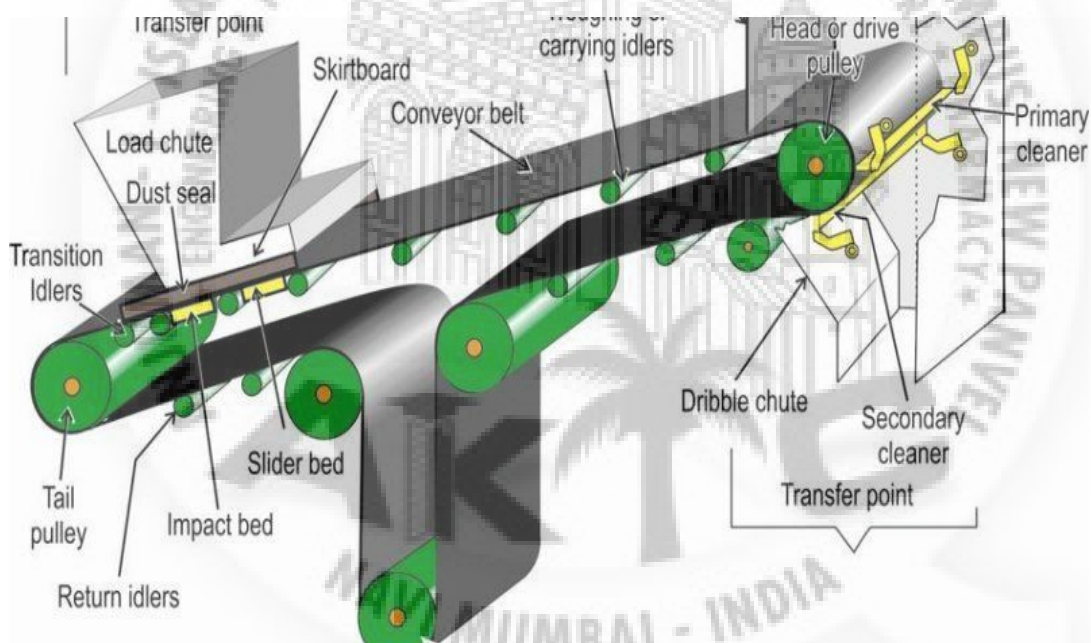

Figure 3.11: Conveyor belt

[Link: [HTTps:// https://www.conbelt.com/how-does-a-conveyor-belt-work/](https://www.conbelt.com/how-does-a-conveyor-belt-work/)]

3.3.2.5 Hydraulics cylinder:-

The hydraulic cylinder is basically a spring return type single acting cylinder. This cylinder is pressurized from only one side due to high force being exerted by fluid during both the extension as well as retraction process. This cylinder is placed along the conveyor belt as soon as the sensor detects the object or waste material it gives the input to the PLC and the PLC will response according to it and energized. As these hydraulic cylinder energies, it pushes the waste to the respective bins.

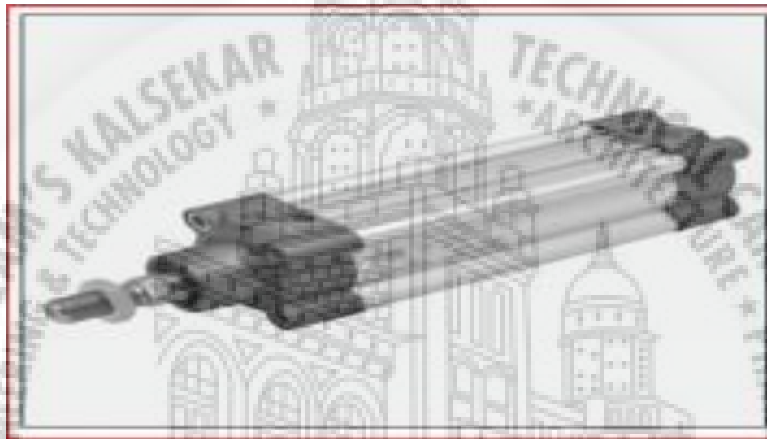

Figure 3.12: Hydraulic cylinder

[Link:[https:// https://www.conbelt.com/how-does-a-conveyor-belt-work/](https://www.conbelt.com/how-does-a-conveyor-belt-work/)]

Chapter 4

Ladder logic Programing

4.1 Program of the System.

As the PLC is a programmable device it requires a software at which the program can be create and installed in the PLC, The five most popular programming technique to program a PLC are ladder diagram (LD) , sequential function charts (SFC) , function block diagram (FBD), structure text(ST) and instruction list(IL). Here we are using ladder diagram programming, and the software use to program Delta PLC is "IOP Soft". This software basically helps the user to communicate PLC with computer. IOP Soft for Delta automation network and devices is a comprehensive factory communication solution, it provides Delta programmable controller access to a wide variety of Rockwell software. The easiest way to think about IOP Soft is something like a communication central.

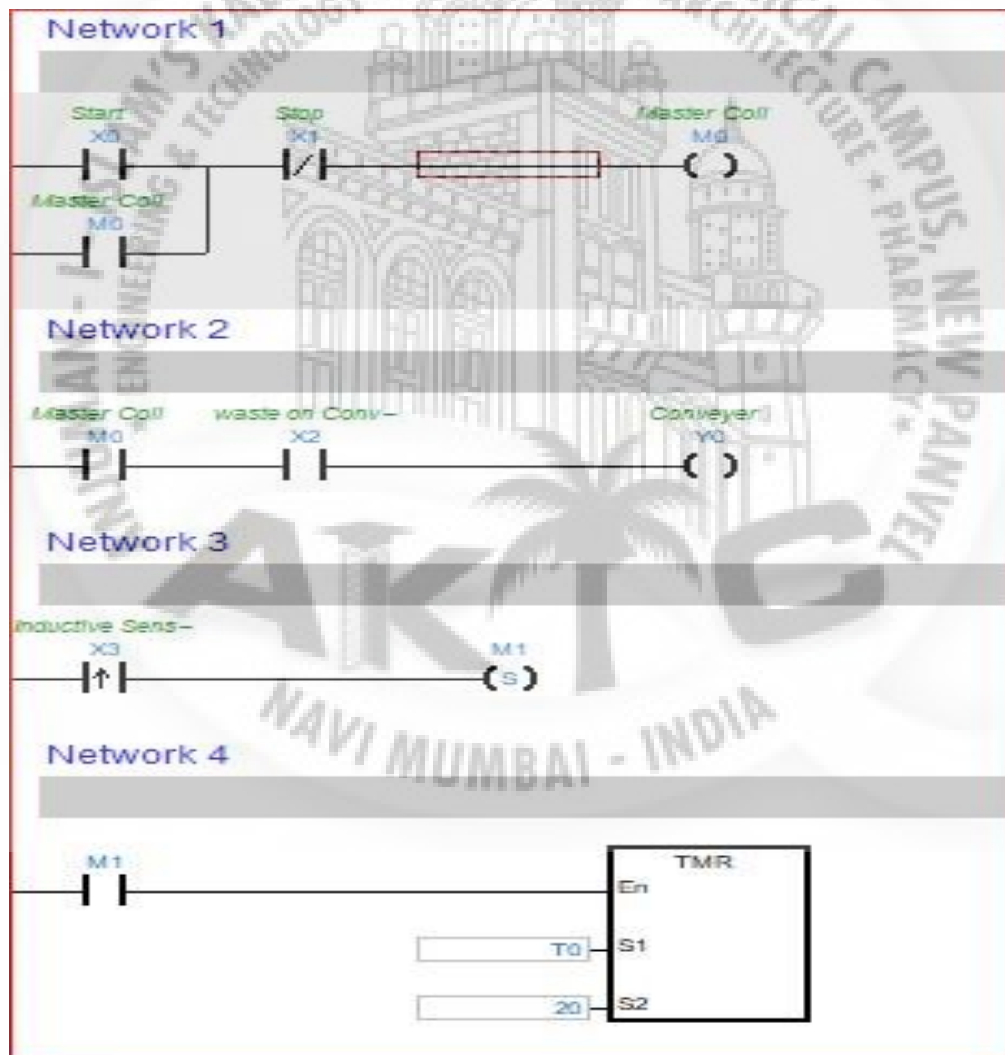

Figure 4.1: Ladder logic program

Chapter 4. Ladder logic program

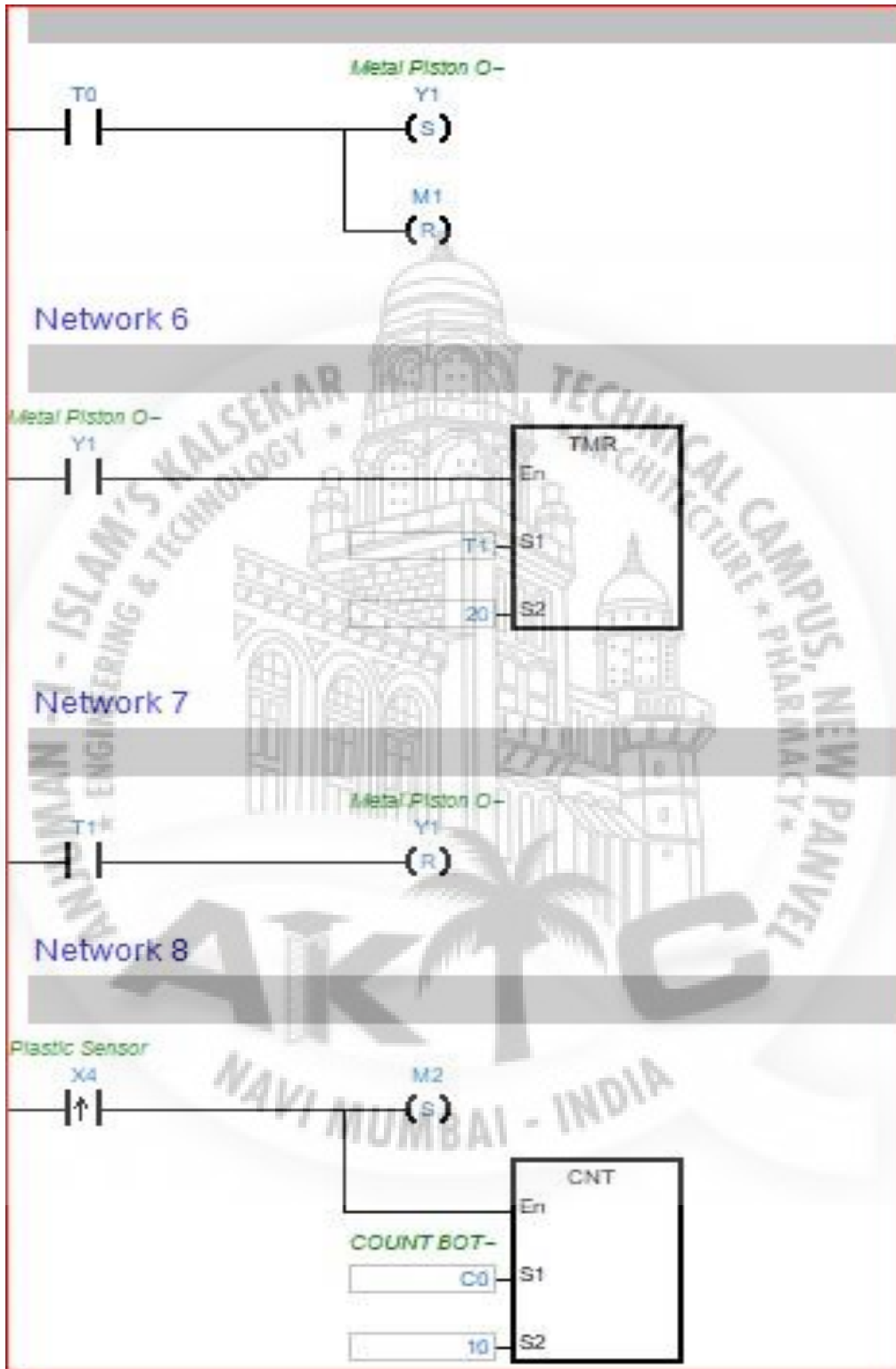

Figure 4.2: Ladder logic program

Chapter 3. Technical Details

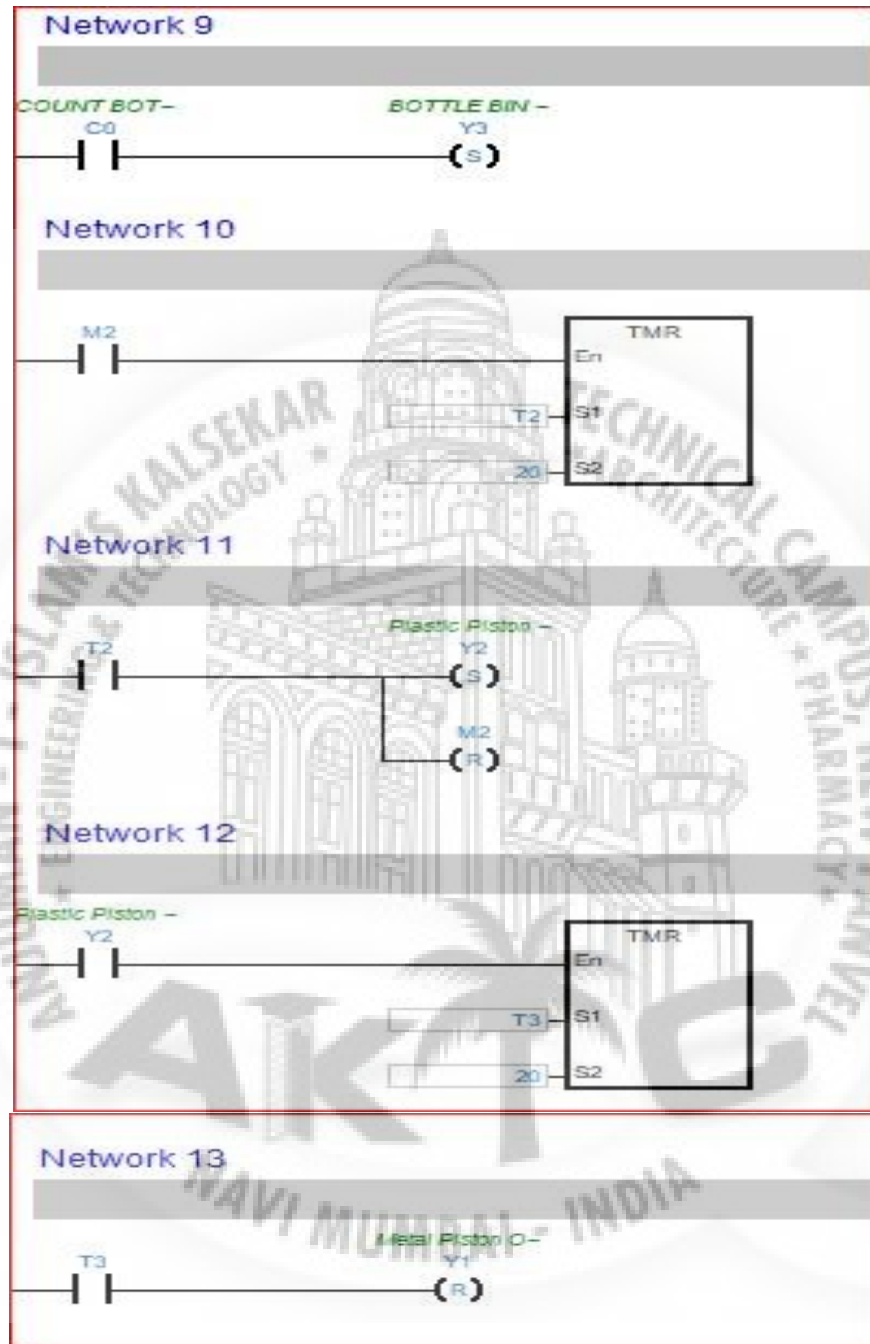
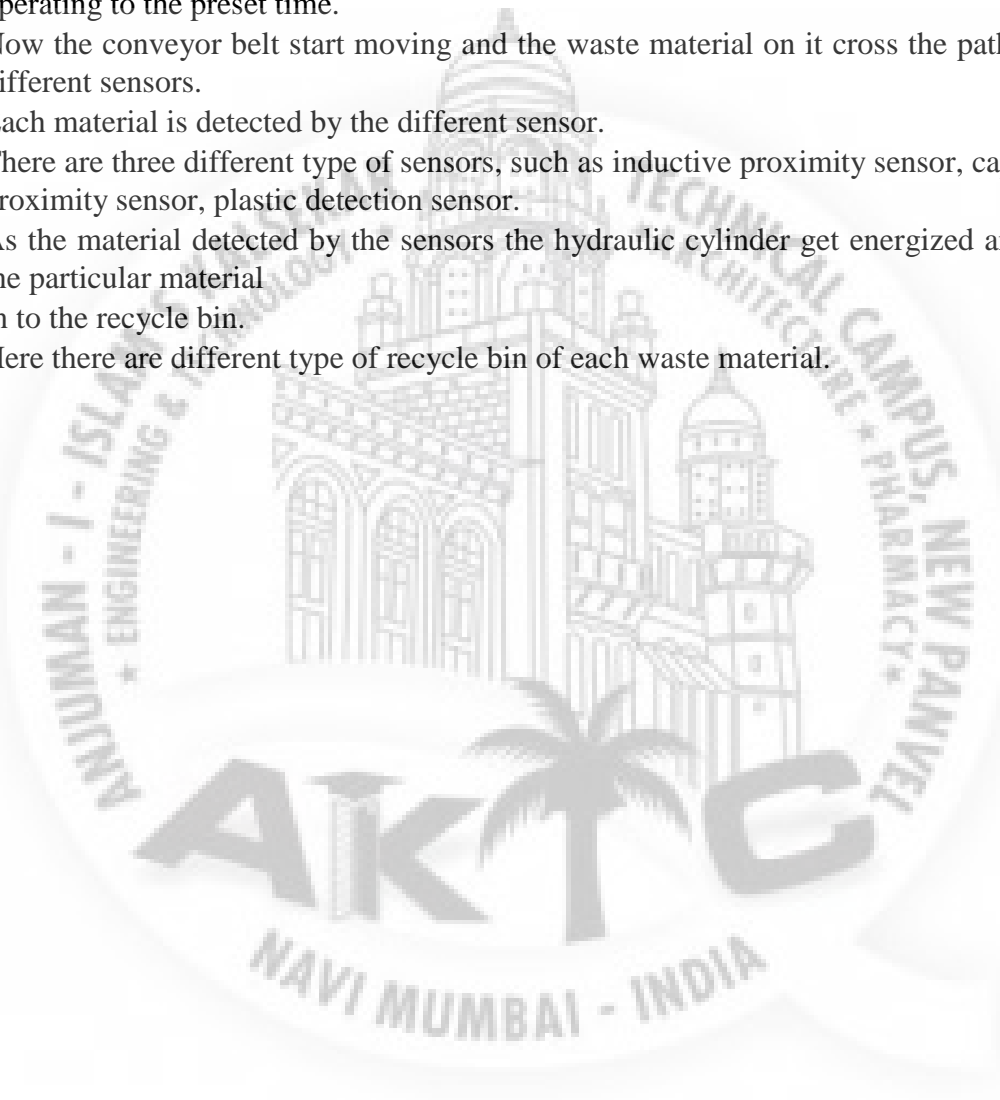

Figure 4.3: Ladder logic program

Chapter 4. Ladder logic program

Description of Ladder program:

- The waste material are placed on to the main conveyor belt by the pre conveyor system.
- As soon as the proximity sensor detect the waste material the conveyor belt starts operating to the preset time.
- Now the conveyor belt start moving and the waste material on it cross the path across different sensors.
- Each material is detected by the different sensor.
- There are three different type of sensors, such as inductive proximity sensor, capacitive proximity sensor, plastic detection sensor.
- As the material detected by the sensors the hydraulic cylinder get energized and push the particular material In to the recycle bin.
- Here there are different type of recycle bin of each waste material.



Chapter 4. Ladder logic program

4.2 Step of writing and executing of program

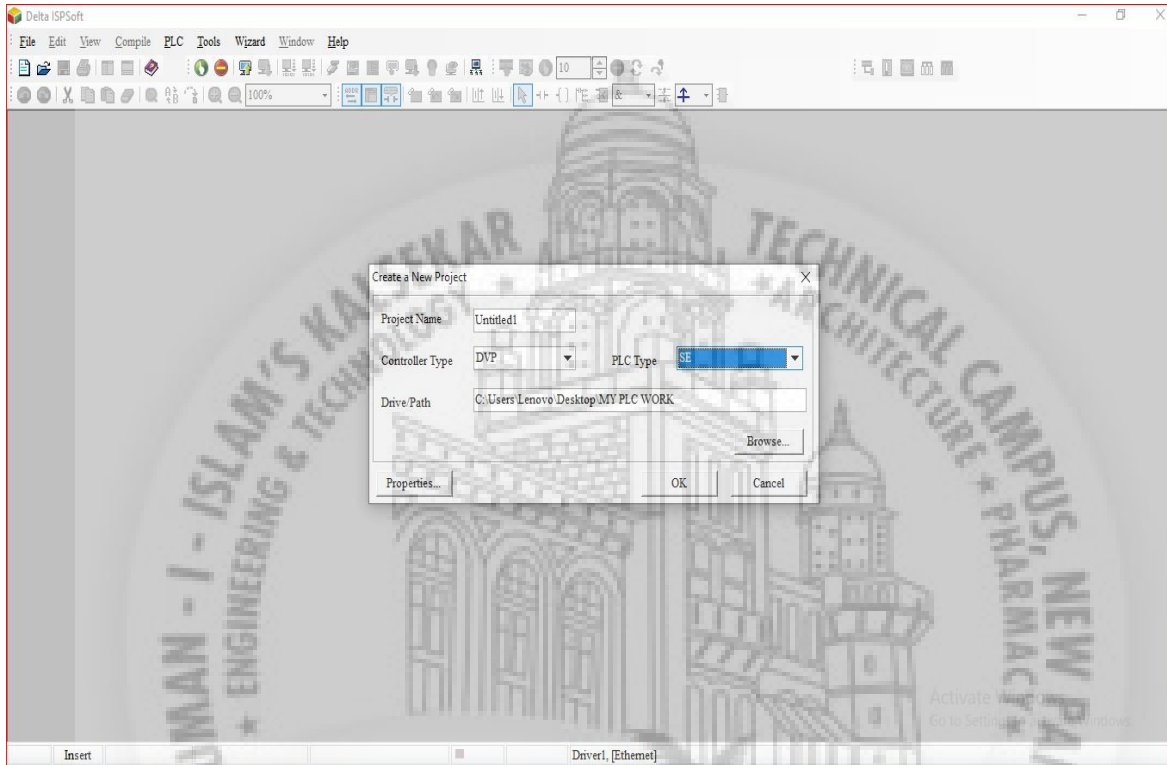

Fig.4.4: New file creation

For starting a program first create a file in which we have to select type of PLC that is SE type which have feature of Ethernet connection.

Chapter 4. Ladder logic program

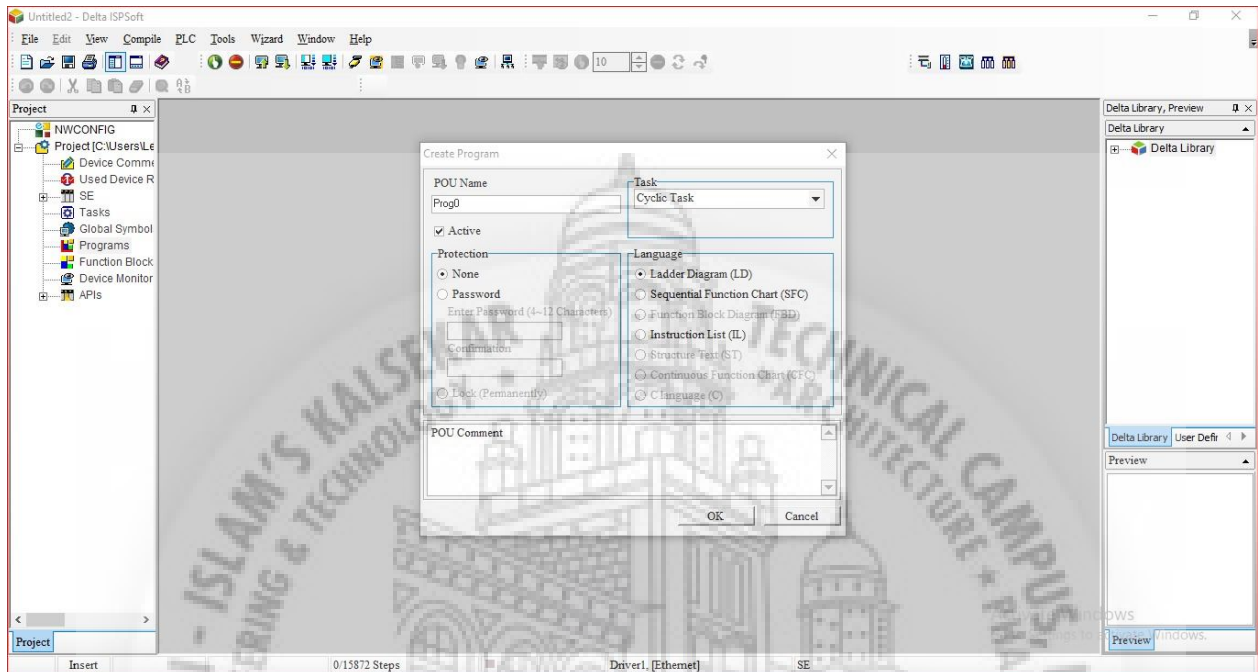

Fig.4.5: Select the type of language

Here we are selecting ladder diagram mode programming and select the Task as Cyclic Task and give the program name.

Chapter 4. Ladder logic program

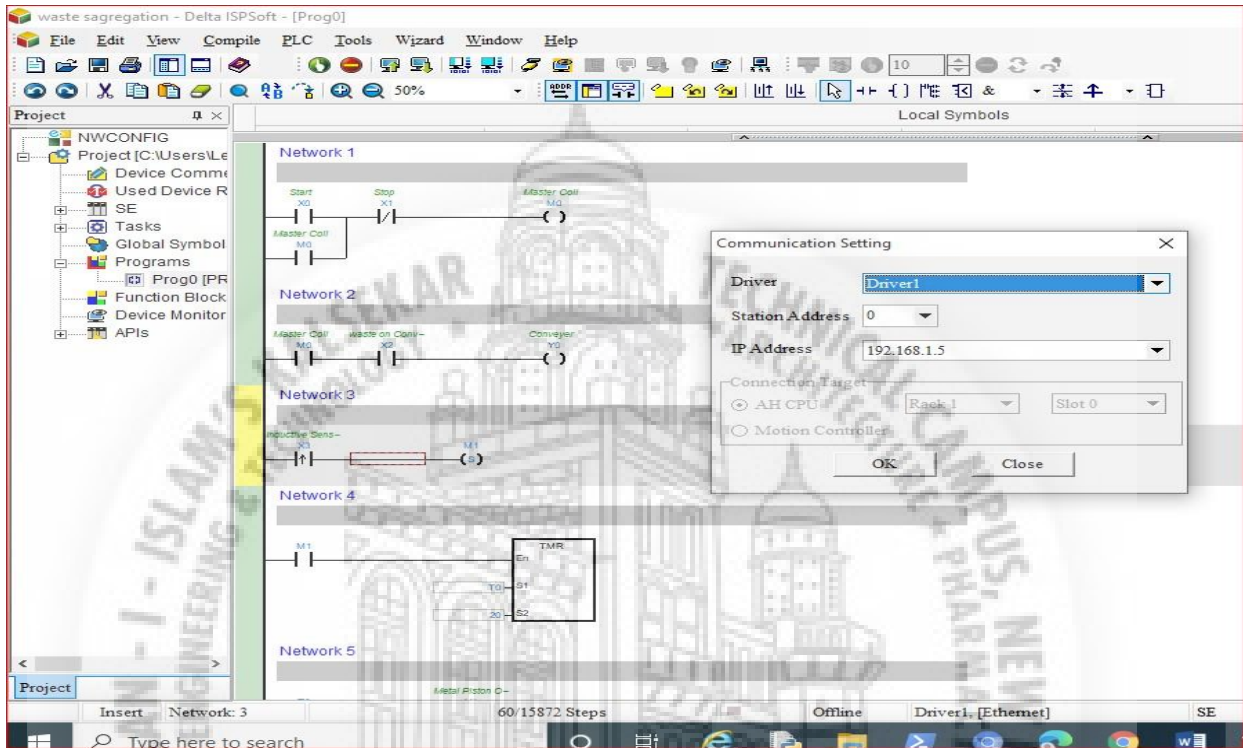

Fig.4.6: Design logic program

Now design the logic programming with the help of switches, coils, timer, counter, memory bits, etc.

Chapter 4. Ladder logic program

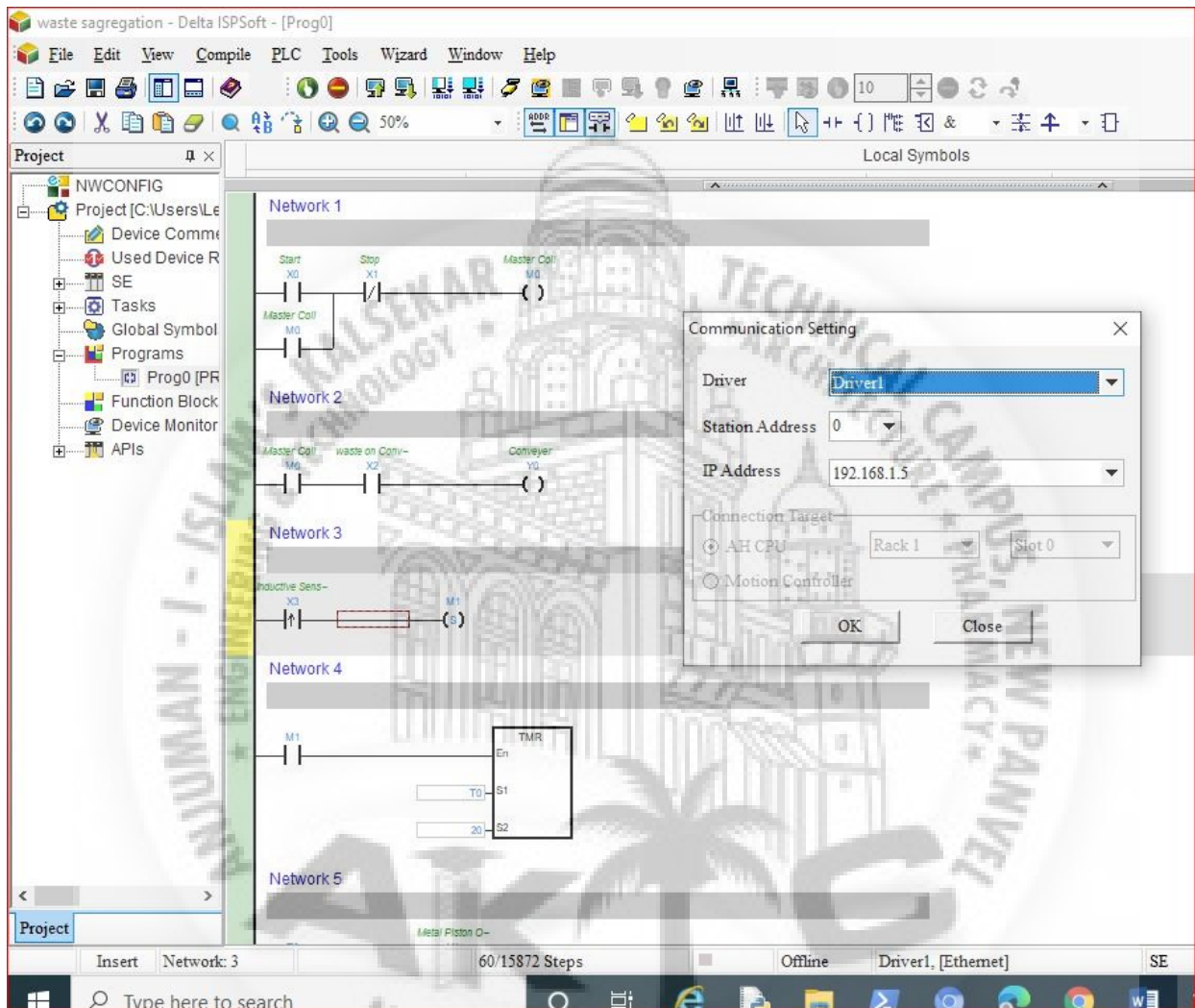

Fig.4.7: Communication setting

As soon as completing the ladder logic program we have to select the communication setting option in order to communicate the program with PLC by selecting the driver, in our case we used SE type of PLC which have Ethernet feature, for that we have to maintain the IP address of the PLC. If we use some other type of PLC then we have to select another driver for communicate PLC for example RS232 cable and RS232 converter.

Chapter 4. Ladder logic program

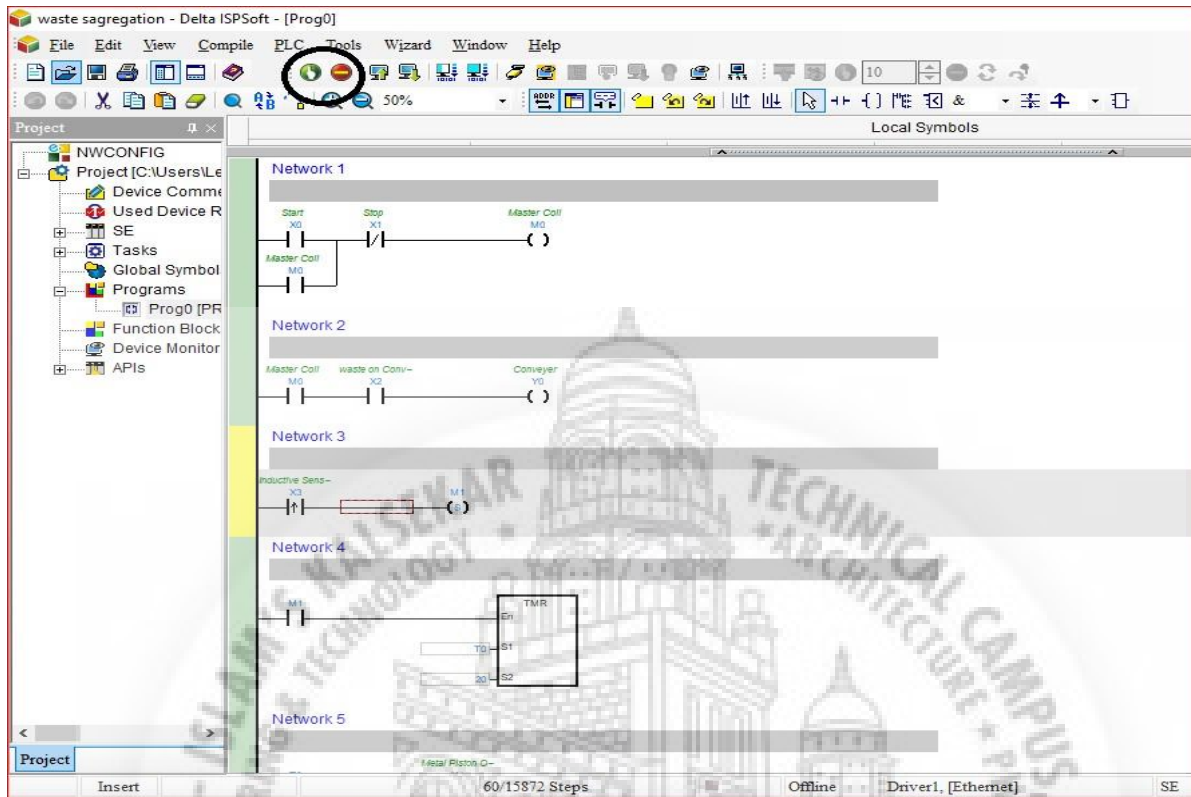

Fig.4.8: RUN and STOP logic program.

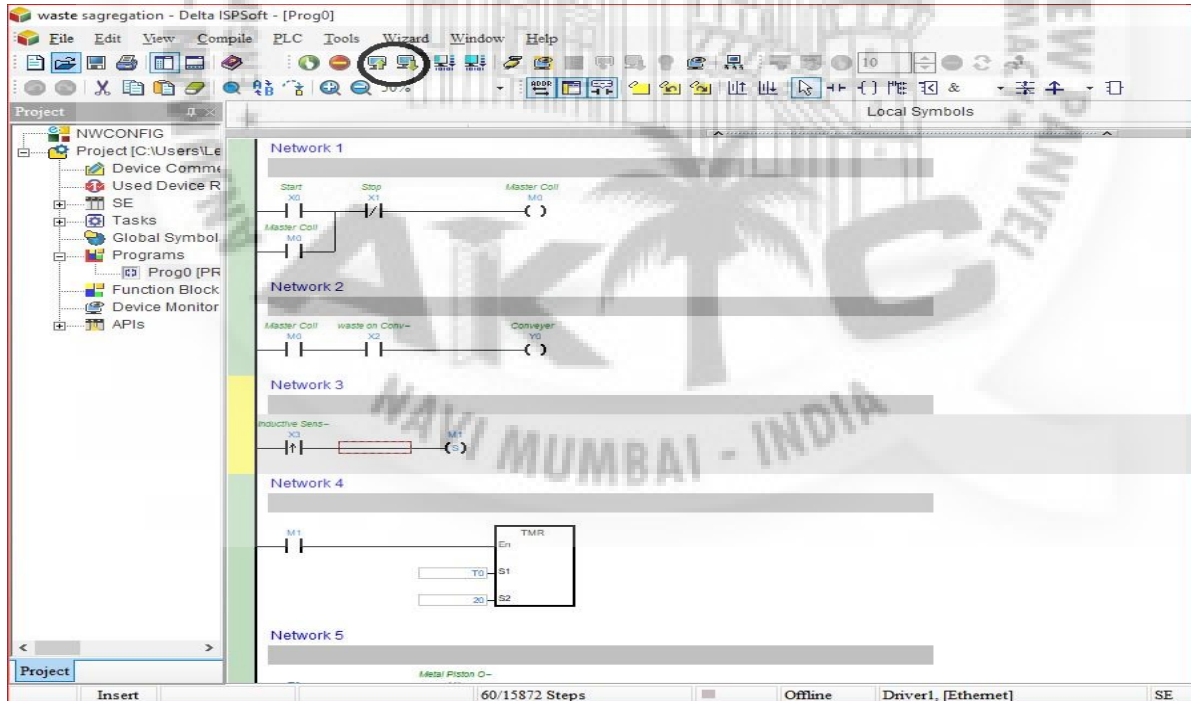

Fig.4.9: Upload and Download logic program.

Chapter 4. Ladder logic program

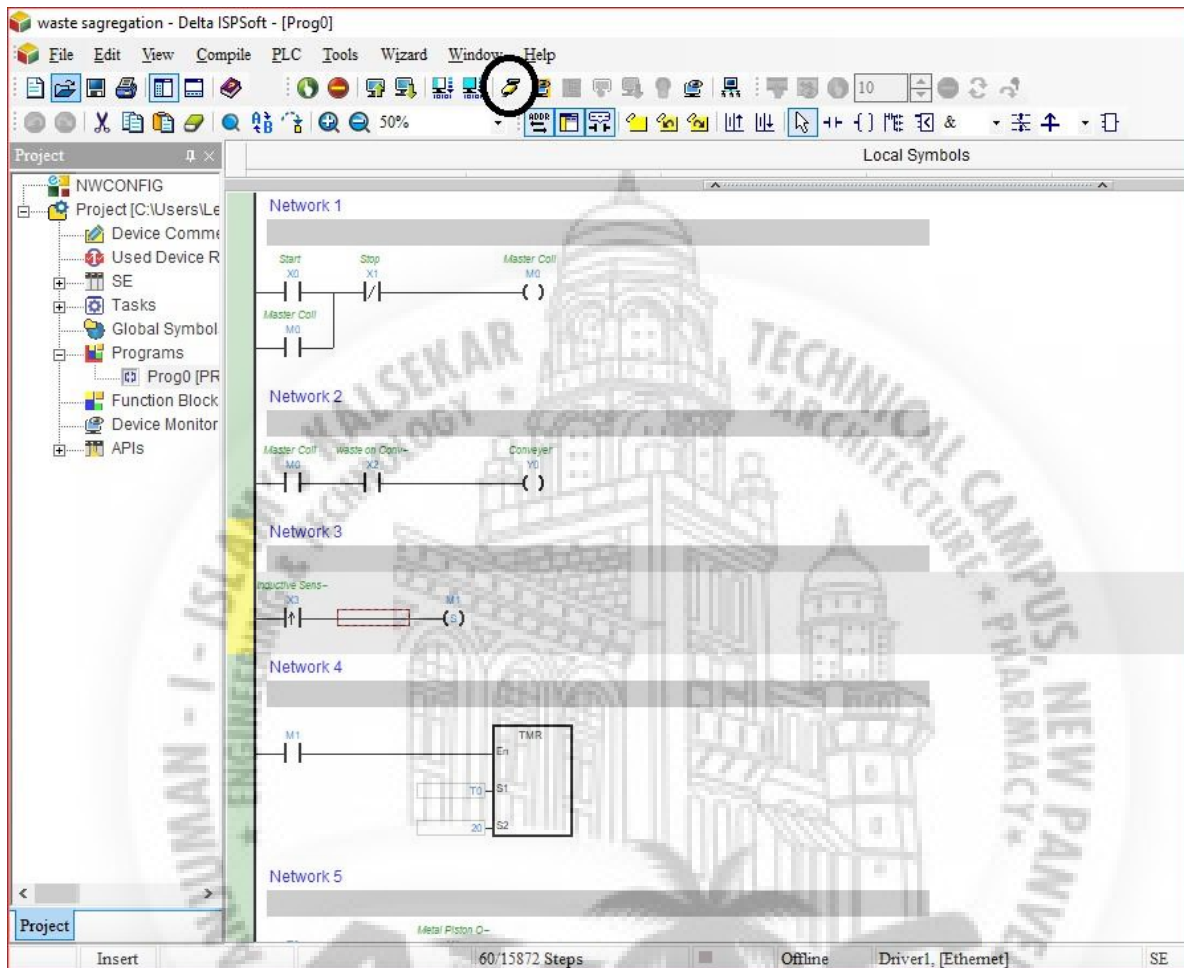

Fig.4.10: Online mode.

Chapter 5

Result

Successfully tested the system with different material



Figure 5.1: POW

[Link:<http://www.usafiplus.org/index.php/services/waste-management/segregation-minimization.html>]

The project automatic material segregation system using industrial tools is built, having the capability to sort out various materials like metal, non-metal. It is made to lower man power usage in any industry having low cost investment. We also have concentrated on making the use of this project very simpler and user friendly. We worked on mainly to cater people with low cost. This is because the main reason why low-cost tools and cheap sensor/transducers are used in this project.

Chapter 6

Conclusion

The project PLC controlled automatic material segregation system has been built. The system is capable of segregating materials like o metal, non-metal, wood, plastic, successfully. The pro- posed system is such that it saves both time and cost. the system is one time investment with low maintenance and one person control system. The system is reasonable for small scale industries where an initial investment is low.



Figure 6.1: HMI Display

Chapter 7

Thesis Plagiarism Report

ORIGINALITY REPORT

18%

SIMILARITY INDEX

14%

INTERNET SOURCES

4%

PUBLICATIONS

14%

STUDENT PAPERS

PRIMARY SOURCES

1

www.aiktcdspace.org:8080

Internet Source

4%

2

www.researchtrend.net

Internet Source

3%

3

[Submitted to Savitribai Phule Pune University](#)

Student Paper

2%

4	www.scribd.com Internet Source	1%
5	ro.scribd.com Internet Source	1%
6	Submitted to Engineers Australia Student Paper	1%
7	Submitted to Meerut Institute of Engineering & Technology Student Paper	1%
8	automation-networks.com Internet Source	1%
9	Snehal Lopes, Sweedle Machado. "IoT based Automatic Waste segregator", 2019 International Conference on Advances in Computing, Communication and Control (ICAC3), 2019 Publication	1%

10	Submitted to K. J. Somaiya College of Engineering Vidyavihar, Mumbai Student Paper	1%
11	Submitted to Thapar University, Patiala Student Paper	1%
12	ijarcet.org Internet Source	<1%
13	Submitted to Anjuman-I-Islam's Kalsekar Technical Campus Student Paper	<1%
14	www.alibaba.com Internet Source	<1%
15	www.coursehero.com Internet Source	<1%

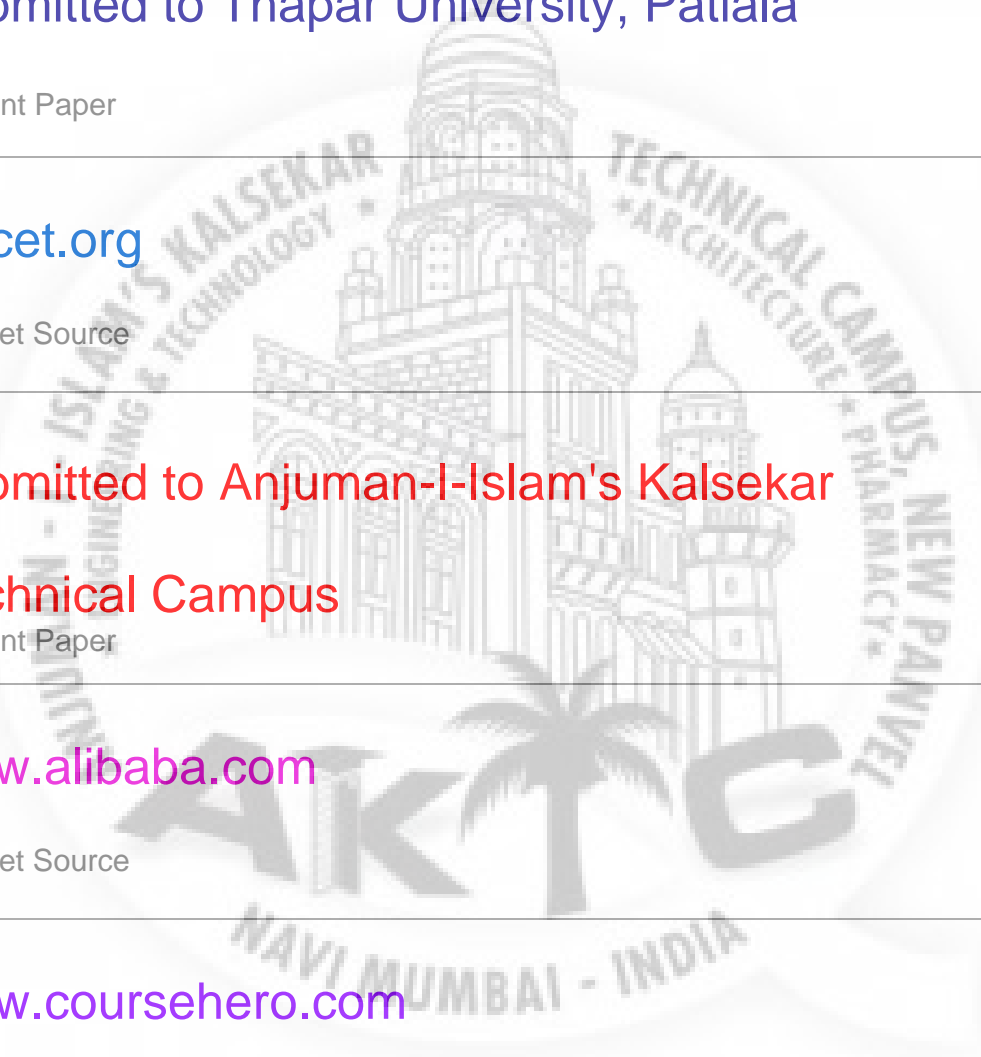

16 Submitted to October University for Modern Sciences and Arts (MSA)
Student Paper <1%

17 Submitted to Higher Education Commission Pakistan
Student Paper <1%

18 Submitted to Universiti Tenaga Nasional
Student Paper <1%

19 Submitted to Universiti Sains Islam Malaysia
Student Paper <1%

Chapter 8

International Conference

Title of Conference : Convergence-2020
Venue of Conference : Poornima Institute Of Engineering Technology, Jaipur
Title of Paper I : Automatic Segregation And Supervision of Waste Material Using Industrial Control Devices.
Author Names : Khan Salman Mehtabali , Khan Athar Wasi Ahmed, Ansari Mohd Afwan
Kamruddin , Fakh Awab Habib
Paper Acceptance Date : 05-03-2020
Accepted : Springer AIS [ISSN: 2524-7565]
Date of Conference : 20th March, 2020
Mode of Presentation : Online

Chapter 8. International Conference

8.1 Acceptance Letter



Fwd: Reminder Regarding Registration for CONVERGENCE-2020

1 message

Salman Khan <salmankhan1997.sk45@gmail.com>

Fri, 13 Mar 2020 at 3:43 pm

To: shifaghare88@gmail.com

----- Forwarded message -----

From: **Convergence 2020** <convergence2020@easychair.org>

Date: Thu, 12 Mar, 2020, 10:26 AM

Subject: Reminder Regarding Registration for CONVERGENCE-2020

To: Salman Khan <salmankhan1997.sk45@gmail.com>

Dear Salman Khan,

!!Greetings from CONVERGENCE-2020!!

Your paper entitled Automatic segregation and supervision of waste material using Industrial Control Devices. was accepted and recommended for publication.

We have decided to extend the deadline for submission for the copyright form, camera ready paper with registration details (e.g. Transaction ID). We hope that the additional time will allow those of you who could not make it in time to registration for the conference due to Holi vacations.

Last Reminder-Please submit your Camera Ready Paper on or before 14-03-2020 with copyright & registration fee.

Please ensure the following before upload the final paper:

1. The paper must be in IEEE Format (Or you can give the prescribed format)
2. The article has few typographical errors which may be carefully looked at Upload Your Paper in both format.docx and .pdf by name as your paper id.docx and your paper id.pdf (like if your paper id is 3 then file name will be 3.docx and 3.pdf)
3. The regular fee will be charged up to 6 pages and after that additional Rs.500 per additional page will be charged.
4. Maximum 8 pages are allowed.

You can find copyright form using below mentioned link: <http://convergence.poornima.org/?controller=pages&action=registration>

Submit your camera ready paper (both docx & pdf) along with copyright form & transaction details using below link: <http://convergence.poornima.org/?controller=upload&action=ucrp> Conference Fee

details:

Delegate	Fee
Expert from Industry/PHD Scholar	:INR 4000/Authors from Academic Institutions
	:INR 3000/Faculty (RTU Affiliated)
	:INR 1500/Student Author(PG)
	:INR 1000/-
Student Author(UG)	:INR 800/Attendee
	:INR 500/-

*Author will pay 500/- for individual certificate.

REGISTRATION FEES DETAILS:

REGISTRATION FEES DETAILS FOR ICSEC-2020

Account Name: PIET CONFERENCE ACCOUNT NO. TWO
Account Number: 665420110000182
Bank: BANK OF INDIA, Ramchandrapura Branch, Jaipur
IFSC Code: BKID0006654
SWIFT Code: BKIDINBBJPR

Registration Fees Details for ICSIE-2020 & ICSIS-2020

Account Name: PIET CONFERENCE ACCOUNT NO. THREE
Account Number: 665420110000183
Bank: BANK OF INDIA, Ramchandrapura Branch, Jaipur
IFSC Code: BKID0006654
SWIFT Code: BKIDINBBJPR

If you have already submitted all details so kindly ignore it.

For any queries contact: icsis@poornima.org
icsec@poornima.org icsie@poornima.org

Contact Details: 9694802324, 9983175627

Thanking you
Dr. Dinesh Goyal
(General Chair Convergence-2020)

Chapter 8. International Conference

8.2 International Conference Paper Plagiarism Report

ORIGINALITY REPORT

3%

SIMILARITY INDEX

2%

INTERNET SOURCES

1%

PUBLICATIONS

3%

STUDENT PAPERS

PRIMARY SOURCES

Submitted to Savitribai Phule Pune University

1 Student Paper

2%

automation-networks.com

2 Internet Source

1%

wcaset.com

3 Internet Source

1%

8.3 International Conference Paper Copyright

SPRINGER NATURE

Publishing Agreement for Contributions in Collected Works

This Publishing Agreement (this “**Agreement**”) has been approved by and entered into between **Fakih Awab Habib**, [Assistant Professor, Anjuman I Islam Kalsekar Technical Campus, Mumbai University, Sector 16, Near Thana Naka, Khandagaon, New Panvel, Navi Mumbai, Maharashtra-410206], **Khan Salman Mehtabali**, [Room No. 516, Subash Nagar, M.I.D.C Road, Nr. Sulzer Pump Company, Digha, Airoli, Navi Mumbai, Thane, Maharashtra-400708], **Khan Athar**, [Bungalow No. 02, Kehkashan Villa, Bholenath Nagar, Mumbra, Thane, Maharashtra-400612], **Ansari Mohd Afwan** [Flat No. 101, Building No. 20, Kap Islampura, Nasheman, Apartment, Bhiwandi, Thane, Maharashtra-421302]. (the “**Author**”) whereas, in the event that the Author is more than one person, **Khan Salman Mehtabali** serves as corresponding author (the “**Corresponding Author**”)

on the one part and

Springer Nature Singapore Pte Ltd.
152 Beach Road, #21-01/04 Gateway East, Singapore 189721, Singapore
(the “**Publisher**”)

on the other part; together hereinafter referred to as the “**Parties**”.

The Publisher intends to publish the Author’s contribution in a collected work provisionally entitled: **Proceedings of Second International Conference on Smart Energy and Communication - ICSEC 2020** (the “**Work**”) edited by: **Dr. Dinesh Goyal, Dr. Pradyumn Chaturved, Prof. Atulya K. Nagar & Dr. S D Purohit** (the “**Editor**”)

The Publisher intends to publish the Work under the imprint **Springer**.
The Work may be published in the book series **Algorithms for Intelligent Systems**.

§1 Contracting authors

When the Author is more than one person then, unless otherwise indicated in this Agreement or agreed in writing by the Publisher: (a) the expression “**Author**” as used in this Agreement will apply collectively for all such persons (each a “**co-author**”); (b) the Corresponding Author hereby warrants and represents that all co-authors of the contribution have expressly agreed that the Corresponding Author has full right, power and authority to sign this Agreement on their behalf, that the Corresponding Author is entitled to act on their behalf, and that they shall be bound by the Corresponding Author, with respect to all matters, responsibilities, notices and communications related to this Agreement; the Corresponding Author shall obtain authorisations and make them available to the Publisher on request; and (c) each co-author is jointly and severally responsible for the Author’s obligations under this Agreement which apply to each co-author individually and to the co-authors collectively and the Publisher shall not be bound by any separate agreement or legal relationship as between the co-authors.

§2 Subject of the Agreement

2.1 The Author will prepare a contribution provisionally entitled:

Automatic segregation and supervision of waste material using Industrial Control Devices.

The expression “**Contribution**” as used in this Agreement means the contribution as identified above, and includes without limitation all related material delivered to the Publisher by or on behalf of the Author whatever its media and form (including text, graphical elements, tables, videos and/or links) in all versions and editions in whole or in part.

2.2 The Contribution may contain links (e.g. frames or in-line links) to media enhancements (e.g. additional documents, tables, diagrams, charts, graphics, illustrations, animations, pictures, videos and/or software) or to social or functional enhancements, complementing the Contribution, which are provided on the Author's own website or on a third party website or repository (e.g. maintained by an institution) subject always to the Author providing to the Editor, at the latest at the delivery date of the manuscript for the Contribution, an accurate description of each media enhancement and its respective website or repository, including its/their owner, nature and the URL. The Publisher is entitled to reject the inclusion of, or suspend, or delete links to all or any individual media enhancements.

2.3 In the event that an index is deemed necessary, the Author shall assist the Editor in its preparation (e.g. by suggesting index terms), if requested by the Editor.

§ 3 Rights Granted

3.1 The Author hereby grants to the Publisher the perpetual, sole and exclusive, world-wide, transferable, sub-licensable and unlimited right to publish, produce, copy, distribute, communicate, display publicly, sell, rent and/or otherwise make available the Contribution in any language, in any versions or editions in any and all forms and/or media of expression (including without limitation in connection with any and all end-user devices), whether now known or developed in the future, in each case with the right to grant further time-limited or permanent rights. The above rights are granted in relation to the Contribution as a whole or any part and with or in relation to any other works.

Without limitation, the above grant includes: (a) the right to edit, alter, adapt, adjust and prepare derivative works; (b) all advertising and marketing rights including without limitation in relation to social media; (c) rights for any training, educational and/or instructional purposes; and (d) the right to add and/or remove links or combinations with other media/works.

The Author hereby grants to the Publisher the right to create, use and/or license and/or sub-license content data or metadata of any kind in relation to the Contribution or parts thereof (including abstracts and summaries) without restriction.

The Publisher also has the right to commission completion of the Contribution in accordance with the Clause "**Author's Responsibilities – Delivery and Acceptance of the Manuscript**" and of an updated version of the Contribution for new editions of the Work in accordance with the Clause "**New Editions**".

3.2 The copyright in the Contribution shall be vested in the name of the **Author**. The Author has asserted their right(s) to be identified as the originator of the Contribution in all editions and versions, published in all forms and media. The Author agrees that all editing, alterations or amendments to the Contribution made by or on behalf of the Publisher or its licensees for the purpose of fulfilling this Agreement or as otherwise allowed by the above rights shall not require the approval of the Author and will not infringe the Author's "moral rights" (or any equivalent rights). This includes changes made in the course of dealing with retractions or other legal issues.

§ 4 Self-Archiving and Reuse

4.1 Self-Archiving: The Publisher permits the Rights Holder to archive the Contribution in accordance with the Publisher's guidelines, the current version of which is set out in the **Appendix "Author's Self-Archiving Guidelines"**.

4.2 Reuse: The Publisher permits the Author to copy, distribute or otherwise reuse the Contribution, without the requirement to seek specific prior written permission from the Publisher, in accordance with the Publisher's guidelines, the current version of which is set out in the **Appendix "Author's Reuse Rights"**.

§ 5 The Publisher's Responsibilities

5.1 Subject always to the other provisions of this Clause below, the Publisher will undertake the production, publication and distribution of the Contribution and the Work in print and/or electronic form at its own expense and risk within a reasonable time after acceptance of the Work unless the Publisher is prevented from or delayed in doing so due to any circumstances beyond its reasonable control. The Publisher shall have the entire control of such production, publication and distribution determined in its sole discretion in relation to any and all editions and versions of the Contribution and the Work, including in respect of all the following matters:

- (a) distribution channels, including determination of markets;
- (b) determination of the range and functions of electronic formats and/or the number of print copies produced;
- (c) publication and distribution of the Contribution, the Work, or parts thereof as individual content elements, in accordance with market demand or other factors;
- (d) determination of layout and style as well as the standards for production;
- (e) setting or altering the list-price, and allowing for deviations from the list-price (if permitted under applicable jurisdiction); (f) promotion and marketing as the Publisher considers most appropriate.

5.2 All rights, title and interest, including all intellectual property or related rights in the typography, design and/or look-and-feel of the Contribution shall remain the exclusive property of and are reserved to the Publisher. All illustrations and any other material or tangible or intangible property prepared at the expense of the Publisher including any marketing materials remain, as between the Parties, the exclusive property of the Publisher. The provisions of this sub-clause shall continue to apply notwithstanding any termination of, and/or any reversion of rights in the Contribution to the Author, under this Agreement.

5.3 Without prejudice to the Publisher's termination and other rights hereunder including under the Clause "**The Author's Responsibilities**", it is agreed and acknowledged by the Parties that nothing in this Agreement shall constitute an undertaking on the part of the Publisher to publish the Contribution unless and until: (i) any and all issues in relation to the Work (including all necessary revisions, consents and permissions) raised by the Publisher have been resolved to the Publisher's satisfaction, and (ii) the Publisher

has given written notice of acceptance in writing of the final manuscript of the entire Work to the Editor. If following (i) and (ii) above the Publisher has not published the Contribution in any form within a reasonable period and the Author has given written notice to the Publisher requiring it to publish within a further reasonable period and the Publisher has failed to publish in any form, then the Author may terminate this Agreement by one month's written notice to the Publisher and all rights granted by the Author to the Publisher under this Agreement shall revert to the Author (subject to the provisions regarding any third party rights under any subsisting licence or sublicense in accordance with the Clause "**Termination**").

The Author may also give such written notice requiring publication on the same terms as above if the Publisher has published the Contribution but subsequently ceases publishing the Contribution in all forms so that it is no longer available.

This shall be the Author's sole right and remedy in relation to such non-publication and is subject always to the Author's continuing obligations hereunder including the Clause "**Warranty**".

§ 6 The Author's Responsibilities

6.1 *Delivery and Acceptance of the Manuscript*

6.1.1 The Author shall deliver the Contribution to the Editor (or, if requested by the Publisher, to the Publisher) on or before **18-12-2020** (the "**Delivery Date**") electronically in the Publisher's standard requested format or in such other form as may be agreed in writing with the Publisher. The Author shall retain a duplicate copy of the Contribution. The Contribution shall be in a form acceptable to the Publisher (acting reasonably) and in line with the instructions contained in the Publisher's guidelines as provided to the Author by the Publisher. The Author shall provide at the same time, or earlier if the Publisher reasonably requests, any editorial, publicity or other information (and in such form or format) reasonably required by the Publisher. The Publisher may exercise such additional quality control of the manuscript as it may decide at its sole discretion including through the use of plagiarism checking systems and/or peer-review by internal or external reviewers of its choice. If the Publisher decides at its sole discretion that the final manuscript does not conform in quality, content, structure, level or form to the stated requirements of the Publisher, the Publisher shall be entitled to terminate this Agreement in accordance with the provisions of this Clause.

6.1.2 The Author must inform the Publisher at the latest on the Delivery Date if the sequence of the naming of any co-authors entering into this Agreement shall be changed. If there are any changes in the authorship (e.g. a co-author joining or leaving), then the Publisher must be notified by the Author in writing immediately and the Parties will amend this Agreement accordingly. The Publisher shall have no obligation to consider publication under this Agreement in the absence of such agreed amendment.

6.1.3 If the Author fails to deliver the Contribution in accordance with the provisions of this Clause above by the Delivery Date (or within any extension period given by the Publisher at its sole discretion) or if the Author (or any co-author) dies or becomes incapacitated or otherwise incapable of performing the Author's obligations under this Agreement, the Publisher shall be entitled to either:

- (a) elect to continue to perform this Agreement in accordance with its terms and the Publisher may commission an appropriate and competent person (who, in the case of co-authors having entered into this Agreement, may be a co-author) to complete the Contribution; or (b) terminate this Agreement with immediate effect by written notice to the Author or the Author's successors, in which case all rights granted by the Author to the Publisher under this Agreement shall revert to the Author/Author's successors (subject to the provisions of the Clause "**Termination**").

6.1.4 The Author agrees, at the request of the Publisher, to execute all documents and do all things reasonably required by the Publisher in order to confer to the Publisher all rights intended to be granted under this Agreement.

6.1.5 The Author warrants that the Contribution is original except for any excerpts from other works including pre-published illustrations, tables, animations, text quotations, photographs, diagrams, graphs or maps, and whether reproduced from print or electronic or other sources ("**Third Party Material**") and that any such Third Party Material is in the public domain (or otherwise unprotected by copyright/other rights) or has been included with written permission from or on behalf of the rights holder (and if requested in a form prescribed or approved by the Publisher) at the Author's expense unless otherwise agreed in writing, or is otherwise used in accordance with applicable law. On request from the Publisher, the Author shall in writing indicate the precise sources of these excerpts and their location in the manuscript. The Author shall also retain the written permissions and make them available to the Publisher on request.

6.2 *Approval for Publishing*

6.2.1 The Author shall proofread the page proofs for the Contribution provided by or on behalf of the Publisher, including checking the illustrations as well as any media, social or functional enhancements and give approval for publishing, if and when requested by the Publisher. The Author's approval for publishing is deemed to have been given if the Author does not respond within a reasonable period of time (as determined by the Publisher) after receiving the proofs. The Publisher shall not be required to send a second set of corrected proofs unless specifically requested by the Author in writing but in any event no further amendments may be made or requested by the Author.

In the event of co-authors having entered into this Agreement the Publisher shall send the page proofs to the Corresponding Author only and all persons entering into this Agreement as Author agree that the Corresponding Author shall correct and approve the page proofs on their behalf.

6.2.2 If the Author makes changes other than correcting typographical errors, the Author shall bear all the Publisher's costs of such alterations to proofs including without limitation to alterations to pictorial illustrations. The Publisher shall have the right to charge and invoice these costs plus value added or similar taxes (if applicable) through its affiliated company Springer Nature Customer Service Center GmbH or Springer Nature Customer Service Center LLC, respectively, to the Author, payable within 14 days of receipt of the invoice.

§ 7 Co-operation

Without prejudice to the warranties and representations given by the Author in this Agreement, the Author shall cooperate fully with the Editor and the Publisher in relation to any legal action that might arise from the publication or intended publication of the Contribution and the Author shall give the Publisher access at reasonable times to any relevant accounts, documents and records within the power or control of the Author. §

8 Warranty

8.1 The Author warrants and represents that:

- (a) the Author has full right, power and authority to enter into and perform its obligations under this Agreement; and
- (b) the Author is the sole legal owner of (and/or has been fully authorised by any additional rights owner to grant) the rights licensed in the Clause "**Rights Granted**" and use of the Contribution shall in no way whatever infringe or violate any intellectual property or related rights (including any copyright, database right, moral right or trademark right) or any other right or interest of any third party subject only to the provisions in the Clause "**The Author's Responsibilities**" regarding Third Party Material (as defined above); and
- (c) the Contribution shall not contain anything that may cause religious or racial hatred or encourage terrorism or unlawful acts or be defamatory (or contain malicious falsehoods), or be otherwise actionable, including, but not limited to, any action related to any injury resulting from the use of any practice or formula disclosed in the Contribution and all of the purported facts contained in the Contribution are according to the current body of science and understanding true and accurate; and
- (d) there is no obligation of confidentiality owed in respect of any contents of the Contribution to any third party and the Contribution shall not contain anything which infringes or violates any trade secret, right of privacy or publicity or any other personal or human right or the processing or publication of which could breach applicable data protection law and that informed consent to publish has been obtained for all research or other featured participants; and
- (e) the Contribution has not been previously licensed, published or exploited and use of the Contribution shall not infringe or violate any contract, express or implied, to which the Author, or any co-author, who had entered into this Agreement, is a party and any academic institution, employer or other body in which work recorded in the Contribution was created or carried out has authorised and approved such work and its publication.

8.2 The Author warrants and represents that the Author, and each co-author who has entered into this Agreement, shall at all times comply in full with:

- (a) all applicable anti-bribery and corruption laws; and
- (b) all applicable data protection and electronic privacy and marketing laws and regulations; and
- (c) the Publisher's ethic rules (available at <https://www.springernature.com/gp/authors>), as may be updated by the Publisher at any time in its sole discretion. The Publisher shall notify the Author in the event of material changes by email or other written means (the "**Applicable Laws**"). If the Author is in material breach of any of the Applicable Laws or otherwise in material breach of accepted ethical standards in research and scholarship, or becomes the subject of any comprehensive or selective sanctions issued in any applicable jurisdiction (e.g. being subject to the OFAC sanctions list) or if, in the opinion of the Publisher, at any time any act, allegation or conduct of or about the Author prejudices the production or successful exploitation of the Contribution and the Work or brings the name and/or reputation of the Publisher or the Work into disrepute, or is likely to do so, then the Publisher may terminate this Agreement in accordance with the Clause "**Termination**".

8.3 The Publisher reserves the right to amend and/or require the Author to amend the Contribution at any time to remove any actual or potential breach of the above warranties and representations or otherwise unlawful part(s) which the Publisher or its internal or external legal advisers identify at any time. Any such amendment or removal shall not affect the warranties and representations given by the Author in this Agreement.

§ 9 Author's Discount and Electronic Access

9.1 The Author, or each co-author, is entitled to purchase for their personal use the Work and other books published by the Publisher at a discount of 40% off the list price, for as long as there is a contractual arrangement between the Author and the Publisher and subject to any applicable book price law or regulation. The copies must be ordered from the affiliated entity of the Publisher (Springer Nature Customer Service Center GmbH or Springer Nature Customer Service Center LLC, respectively). Resale of such copies is not permitted.

9.2 The Publisher shall provide the electronic final published version of the Work to the Author, provided that the Author has included their email address in the manuscript of the Contribution.

§ 10 Consideration

10.1 The Parties agree that the Publisher's agreement to its contractual obligations in this Agreement in respect of its efforts in considering publishing and promoting the Contribution and the Work is good and valuable consideration for the rights granted and obligations undertaken by the Author under this Agreement, the receipt, validity and sufficiency of which is hereby acknowledged by the Author.

The Parties expressly agree that no royalty, remuneration, licence fee, costs or other moneys whatsoever shall be payable to the Author, subject to the following provisions of this Clause.

10.2 The Publisher and the Author each have the right to authorise collective management organisations ("**CMOs**") of their choice to manage some of their rights. Reprographic and other collectively managed rights in the Contribution ("**Collective Rights**") have been or may be licensed on a non-exclusive basis by each of the Publisher and the Author to their respective CMOs to administer the Collective Rights under their reprographic and other collective licensing schemes ("**Collective Licences**"). Notwithstanding the other provisions of this Clause, the Publisher and the Author

shall each receive and retain their share of revenue from use of the Contribution under Collective Licences from, and in accordance with the distribution terms of their respective CMOs. To the fullest extent permitted by law, any such revenue is the sole property of the Publisher and the Author respectively and, if applicable, the registration and taxation of that revenue is the sole responsibility of the respective recipient party. The Publisher and the Author shall cooperate as necessary in the event of any change to the licensing arrangements set out in this Clause.

§ 11 New Editions

11.1 The Publisher has the sole right to determine whether to publish any subsequent edition of the Work containing an updated version of the Contribution, but only after reasonable consultation with the Author. Once notified by the Publisher that an update of the Contribution is deemed necessary, the Author agrees to deliver an updated manuscript in accordance with the terms of the Clause "**The Author's Responsibilities**" and the other relevant provisions of this Agreement, together with the material for any new illustrations and any other supporting content including media enhancements, within a reasonable period of time (as determined by the Publisher) after such notification. Substantial changes in the nature or size of the Contribution require the written approval of the Publisher at its sole discretion. The terms of this Agreement shall apply to any new edition of the Work that is published under this "**New Editions**" Clause.



11.2 If the Author, for whatever reason, is unwilling, unable or fails (including as a result of death or incapacity) to submit an updated manuscript that meets the terms of this Agreement within the above stated period, then the Publisher is entitled to revise, update and publish the content of the existing edition or to designate one or more individuals (which, where co-authors have entered into this Agreement, may be one or more of the co-authors) to prepare this and any future editions provided that the new editions shall not contain anything that is a derogatory use of the Author's work that demonstrably damages the Author's scientific reputation. In such case, the Author shall not participate in preparing any subsequent editions. The Author agrees that the Publisher shall be entitled but not obliged to continue to use the name of Author on any new editions of the Work together with the names of the person or persons who contributed to the new editions. Should the Author or the Author's successors object to such continuing use then they must notify the Publisher in writing when first contacted by the Publisher in connection with any new edition.

§12 Termination

12.1 In addition to the specific rights of termination set out in the Clause "The Publisher's Responsibilities" and the Clause "The Author's Responsibilities", either Party shall be entitled to terminate this Agreement forthwith by notice in writing to the other Party if the other Party commits a material breach of the terms of the Agreement which cannot be remedied or, if such breach can be remedied, fails to remedy such breach within 45 days of being given written notice to do so.

12.2 Termination of this Agreement, howsoever caused, shall not affect:

- (a) any subsisting rights of any third party under any licence or sub-licence validly granted by the Publisher prior to termination and the Publisher shall be entitled to retain its share of any sum payable by any third party under any such licence or sub-licence;
- (b) except where stated otherwise in this Agreement, any claim which either Party may have against the other for damages or otherwise in respect of any rights or liabilities arising prior to the date of termination;
- (c) the Publisher's right to continue to sell any copies of the Work which are in its power, possession or control as at the date of expiry or termination of this Agreement for a period of 6 months on a non-exclusive basis.

§13 General Provisions

13.1 This Agreement, and the documents referred to within it, constitute the entire agreement between the Parties with respect to the subject matter hereof and supersede any previous agreements, warranties, representations, undertakings or understandings. Each Party acknowledges that it is not relying on, and shall have no remedies in respect of, any undertakings, representations, warranties, promises or assurances that are not set forth in this Agreement. Nothing in this Agreement shall exclude any liability for or remedy in respect of fraud, including fraudulent misrepresentation. This Agreement may be modified or amended only by agreement of the Parties in writing. For the purposes of modifying or amending this Agreement, "in writing" requires either a document written and signed by both the Parties or an electronic confirmation by both the

Parties with DocuSign or a similar e-signature solution. Any notice of termination and/or reversion and, where applicable, any preceding notices (including any requesting remediable action under the Clause "Termination") must be provided in writing and delivered by post, courier or personal delivery addressed to the physical address of the relevant Party as set out at the beginning of this Agreement or any replacement address notified to the other Party for this purpose. All such notices shall become effective upon receipt by the other Party. Receipt is deemed to have taken place five working days after the respective notice was sent by post or left at the address by courier or personal delivery. If the Publisher is the terminating Party the notice need only be provided to the address of the Corresponding Author. If the Author is the terminating Party a copy of the notice must also be sent to the Publisher's Legal Department located at Heidelberger Platz 3, 14197 Berlin, Germany.

13.2 Nothing contained in this Agreement shall constitute or shall be construed as constituting a partnership, joint venture or contract of employment between the Publisher and the Author. No Party may assign this Agreement to third parties but the Publisher may assign this Agreement or the rights received hereunder to its affiliated companies. In this Agreement, any words following the terms "include", "including", "in particular", "for example", "e.g." or any similar expression shall be construed as illustrative and shall not limit the sense of the words preceding those terms.

13.3 If any difference shall arise between the Author and the Publisher concerning the meaning of this Agreement or the rights and liabilities of the Parties, the Parties shall engage in good faith discussions to attempt to seek a mutually satisfactory resolution of the dispute. This Agreement shall be governed by, and shall be construed in accordance with, the laws of the Republic of Singapore. The courts of Singapore, Singapore shall have the exclusive jurisdiction.

13.4 A person who is not a party to this Agreement (other than an affiliate of the Publisher) has no right to enforce any terms or conditions of this Agreement. This Agreement shall be binding upon and inure to the benefit of the successors and assigns of the Publisher. If one or more provisions of this Agreement are held to be unenforceable (in whole or in part) under applicable law, each such provision shall be deemed excluded from this Agreement and the balance of the Agreement shall remain valid and enforceable but shall be interpreted as if that provision were so excluded. If one or more provisions are so excluded under this Clause then the Parties shall negotiate in good faith to agree an enforceable replacement provision that, to the greatest extent possible under applicable law, achieves the Parties' original commercial intention.

The Corresponding Author signs this Agreement on behalf of any and all co-authors.

Signature of Corresponding Author:

Date:

.....

18/04/2020
.....

For internal use only:

Order Number: 89075069

GPU/PD/PS: 3/32/8041

Book_contributor_EN (Limited) V1.1

Appendix “Author’s Self-Archiving Rights”

The Publisher acknowledges that the Author retains rights to archive the Contribution but only subject to and in accordance with the following provisions:

1. Preprint:

A “**Preprint**” is defined as the Author’s version of the Contribution submitted to the Publisher but before any peer-review or any other editorial work by or on behalf of the Publisher has taken place.

The Author may make available the Preprint of the Contribution for personal and private reading purposes only on any of:

- (a) the Author’s own personal, self-maintained website over which the Author has sole operational control; and/or
- (b) a legally compliant, non-commercial preprint server, such as but not limited to arXiv, bioRxiv and RePEc; provided always that once the “Version of Record” (as defined below) of the Contribution has been published by or on behalf of the Publisher, the Author shall immediately ensure that any Preprint made available above shall contain a link to the Version of Record and the following acknowledgement:

“This is a preprint of the following chapter: [author of the chapter], [chapter title], published in [book title], edited by [editor of the book], [year of publication], [publisher (as it appears on the cover of the book)] reproduced with permission of [publisher (as it appears on the copyright page of the book)]. The final authenticated version is available online at: <http://dx.doi.org/> [insert DOI]”.

2. Author’s Accepted Manuscript:

The “Author’s Accepted Manuscript” (“**AAM**”) is defined as the version of the Contribution following any peer-review and acceptance, but prior to copyediting and typesetting, by or on behalf of the Publisher.

The Author may make available the AAM of the Contribution on any of: (a) the Author’s own, personal, self-maintained website over which the Author has sole operational control; and/or (b) the Author’s employer’s internal website or their academic institution or funder’s repository; provided that in each case the respective part of the AAM is not made publicly available until after the Embargo Period.

The “**Embargo Period**” is a period ending **twelve** (12) months from the first publication of the “Version of Record” (as defined below) of the Contribution by or on behalf of the Publisher.

The Author must ensure that any part of the AAM made available contains the following:

“Users may only view, print, copy, download and text- and data-mine the content, for the purposes of academic research. The content may not be (re-)published verbatim in whole or in part or used for commercial purposes. Users must ensure that the author’s moral rights as well as any third parties’ rights to the content or parts of the content are not compromised.” These terms shall also be applicable to the Author. Once the Version of Record (as defined below) of the Contribution has been published by or on behalf of the Publisher the Author shall immediately ensure that any part of the AAM made available shall contain a link to the Version of Record and the following acknowledgement: *“This is an Author Accepted Manuscript version of the following chapter: [author of the chapter], [chapter title], published in [book title], edited by [editor of the book], [year of publication], [publisher (as it appears on the cover of the book)] reproduced with permission of [publisher (as it appears on the copyright page of the book)]. The final authenticated version is available online at: <http://dx.doi.org/> [insert DOI]”.*

3. Version of Record:

The “**Version of Record**” is defined as the final version of the Contribution as originally published, and as may be subsequently amended following publication in a contractually compliant manner, by or on behalf of the Publisher.

4. Any linking, collection or aggregation of self-archived Contributions from the same Work is strictly prohibited.

Appendix “Author’s Reuse Rights”

1. The Publisher acknowledges that the Author retains the ability to copy, distribute or otherwise reuse the Contribution, without the requirement to seek specific prior written permission from the Publisher, (“**Reuse**”) subject to and in accordance with the following provisions:

(a) Reuse of the Contribution or any part of it is permitted in a new edition of the Work or in a new monograph or new textbook written by the same Author provided that in each case the new work is published by the Publisher under a publishing agreement with the Publisher; and (b) Reuse of the Version of Record (as defined below) of the Contribution or any part of it is permitted in a thesis written by the same Author, and the Author is entitled to make a copy of the thesis containing content of the Contribution available in a repository of the Author’s academic institution; and

(c) any other Reuse of the Contribution in a new book, book chapter, proceedings or journal article, whether published by the Publisher or by any third party, is limited to three figures (including tables) or single text extracts of less than 400 words; and

(d) any further Reuse of the Contribution is permitted only to the extent and in so far as is reasonably necessary: (i) to share the Contribution as a whole to no more than 10 research colleagues engaged by the same institution or employer as the Author for each

colleague's personal and private use only; (ii) for classroom teaching use by the Author in their respective academic institution provided that this does not permit inclusion of any of the Contribution in course packs for sale or wider distribution to any students, institutions or other persons nor any other form of commercial or systematic exploitation; or (iii) for the Author to use all or parts of the Contribution in the further development of the Author's scientific and/or academic career, for private use and research or within a strictly limited circulation which does not allow the Contribution to become publicly accessible nor prejudice sales of, or the exploitation of the Publisher's rights in, the Contribution (e.g.7 attaching a copy of the Contribution to a job or grant application).

2. Any Reuse must be based on the Version of Record only, and provided the original source of publication is cited according to current citation standards. The "**Version of Record**" is defined as the final version of the Contribution as originally published, and as may be subsequently amended following publication in a contractually compliant manner, by or on behalf of the Publisher.
3. In each case where the Author has Reuse rights or the Publisher grants specific use rights to the Author according to the above provisions, this shall be subject always to the Author obtaining at the Author's sole responsibility, cost and expense the prior consent of any co-author(s) and/or any relevant third party.
4. Any linking, collection or aggregation of reused Contributions from the same Work is strictly prohibited



Chapter 9. International Conference Certificate

Scopus
Indexed Publication

Springer
Springer 485 Lakeside Drive, Hoboken, NJ 07030

Convergence 2020
"The Smart City"
Role of Engineers In Innovation and Technological Advancement

March 20-21, 2020

International Conference on
Smart Innovations for Society (ICSIS-2020)

Certificate of Paper Presenter

This is to certify that

Dr./Mr./Ms. Athar Khan
from Anjuman Islam Kalsekar Technical Campus has successfully presented Paper, titled
Automatic Segregation And Supervision of Waste Material Using Industrial Control Devices.
in International Conference on Smart Innovations for Society held on March 20-21, 2020
at Department of Applied Science, Poornima Institute of Engineering & Technology, Jaipur, India.

[Signature]
Dr. Sama Jain
Convener

[Signature]
Dr. Gautam Singh
Program Chair

[Signature]
Dr. Dinesh Goyal
General Chair

In Association with: *[Logos: Oar Heritage Journal, JCP, JES, etc.]*

Organized by: **POORNIMA**
INSTITUTE OF ENGINEERING & TECHNOLOGY
Affiliated to RTU, Kota • Approved by AICTE & UGC under 2F • Accredited by NAAC and NBA

Technically Co-Sponsored by: *[Logos: JIPMER, etc.]*

Scopus
Indexed Publication

BENTHAM SCIENCE PUBLISHERS

Convergence 2020
"The Smart City"
Role of Engineers in Innovation and Technological Advancement

Springer
Springer A11 Series (ISSN 2024-7566)

March 20-21, 2020

International Conference on
Smart Innovations for Society (ICSIS-2020)

Certificate of Paper Presenter

This is to certify that

Dr./Mr./Ms. Mohd. Afwan Ansari
from Anjuman Dham Kalkeri Technical Campus has successfully presented Paper, titled
Automatic Segregation And Supervision of Waste Material Using Industrial Control Devices
in International Conference on Smart Innovations for Society held on March 20-21, 2020
at Department of Applied Science, Poornima Institute of Engineering & Technology, Jaipur, India.

[Signature]
Dr. Sama Jain
Convener

[Signature]
Dr. Gautam Singh
Program Chair

[Signature]
Dr. Dinesh Goyal
General Chair

In Association with: Our Heritage Journal, JCP, JET, JES, JCR, IJvy Scientific, Geography

Organized by: POORNA INSTITUTE OF ENGINEERING & TECHNOLOGY

Technically Co-Sponsored by: [Logos of various institutions]

AIKTC CAMPUS, POORNIMA INSTITUTE OF ENGINEERING & TECHNOLOGY, JAIPUR - INDIA

Affiliated to RTU, Kota • Approved by AICTE & UGC under 2013 • Accredited by NAAC and NBA

Chapter 9. International Conference Certificate

Scopus
Indexed Publication

BENTHAM SCIENCE PUBLISHERS LTD.

"The Smart City"

Convergence 2020
Role of Engineers in Innovation and Technological Advancement

Springer
Springer ADS Service (© 2020-1999)

March 20-21, 2020

International Conference on Smart Innovations for Society (ICSIS-2020)

Certificate of Paper Presenter

This is to certify that

Dr./Mr./Ms. Mohd. Faraz Shaikh

from Anjuman Islam Kalsek technical Campus has successfully presented Paper, titled Automatic Segregation And supervision of Waste Material Using Industrial Control Devices in International Conference on Smart Innovations for Society held on March 20-21, 2020 at Department of Applied Science, Poornima Institute of Engineering & Technology, Jaipur, India.

Dr. Sama Jain
Convener

Dr. Gautam Singh
Program Chair

Dr. Dinesh Goyal
General Chair

In Association with

Organized by

Technically Co-Sponsored by

POORNIMA
INSTITUTE OF ENGINEERING & TECHNOLOGY
Affiliated to RTU, Kota • Approved by AICTE & USC under 2013 • Accredited by NAAC and NBA

Logos: Scopus, Bentham Science, Springer, JCP, JET, JES, Ivy Scientific, Geomatics, JKR, Poornima, and various technical societies.

Chapter 9

Internship

Role of Salman and Athar in Absolute Motion : We both joined Absolute Motion Pvt. Ltd. from 30th of August, 2019. We joined this company as a Junior Application Engineer. First two months was our training period where we learned all the necessary skills for the completion of the project. The day we received this project, company assigned us to complete the whole project. We played an Application Engineer role and successfully completed the project.

Role of Afwan and Faraz in Pinnacle Automation : We both joined Pinnacle Pvt. Ltd. from 30th of August, 2019. We joined this company as a Junior Application Engineer. First two months was our training period where we learned all the necessary skills for the completion of the project. The day we received this project, company assigned us to complete the whole project. We played an Application Engineer role and successfully completed the project.

9.1 Internship Offer Letter of Salman

Internship Offer Letter



To

Mr. Khan Salman Mehtabali

Navi Mumbai

Contact No: 8693044264

Email ID: smgkhan07@gmail.com

Dear Mr. Salman,

We are pleased to offer you an internship in our organization as Jr. Application Engineer Intern from 30/08/2019 for 6 months. The period of internship can be revised based on your performance.

No remuneration will be paid to you during your internship period.

We congratulate you on your internship with Absolute Motion Private Limited and wish you a long and successful career with us.

We are confident that your contribution will take us further in our journey towards becoming a reputed firm in Industrial Automation and Robotics.

We assure you of our support for your professional development and growth.

Yours truly,

Alister D'Silva

Accepted and Agreed

Director

Absolute Motion Private Limited

Registered Address :

2A-302 Adarsh Park CHS, Khambalpada, Opposite Mahanagar Gas Station, Near Maruti Mega service center, Kalyan-Dombivli Road, Dombivli (East) 421201, Thane. MH, INDIA

Work Address:

B-601, Keshav Shristi Complex, Opposite Dreams Mall, Above JK Children's Hospital, L.B.S Road, Bhandup (West) Mumbai 400078. MH, INDIA.

Phone : +91 77108 33666, +91 93226 56103

Email : info@absolutemotion.in

Website : www.absolutemotion.in

CIN : U29305MH2018PTC316063

9.2 Internship Offer Letter of Athar

Internship Offer Letter



To

Mr. Khan Salman Mehtabali

Navi Mumbai

Contact No: 8693044264

Email ID: smgkhan07@gmail.com

Dear Mr. Salman,

We are pleased to offer you an internship in our organization as Jr. Application Engineer Intern from 30/08/2019 for 6 months. The period of internship can be revised based on your performance.

No remuneration will be paid to you during your internship period.

We congratulate you on your internship with Absolute Motion Private Limited and wish you a long and successful career with us.

We are confident that your contribution will take us further in our journey towards becoming a reputed firm in Industrial Automation and Robotics.

We assure you of our support for your professional development and growth.

Yours truly,

Alister D'Silva

Accepted and Agreed

Director

Absolute Motion Private Limited

Registered Address :

2A-302 Adarsh Park CHS, Khambalpada, Opposite Mahanagar Gas Station, Near Maruti Mega service center, Kalyan-Dombivli Road, Dombivli (East) 421201, Thane. MH, INDIA

Work Address:

B-601, Keshav Shristi Complex, Opposite Dreams Mall, Above JK Children's Hospital, L.B.S Road, Bhandup (West) Mumbai 400078. MH, INDIA.

Phone : +91 77108 33666, +91 93226 56103

Email : info@absolutemotion.in

Website : www.absolutemotion.in

CIN : U29305MH2018PTC316063

9.3 Internship Offer Letter of Faraz



Date: 03.09.2019

To,

Whomsoever it may concern

This is to state that **Mr. Mohammed Faraz Mohd Riyaz Shaikh** has been appointed as an Intern by our company **Pinnacle Industrial Controls Pvt Ltd** in **Projects** team for an **Internship** period of **seven months**.

Stipend for these months will be **Rupees 5000/- (Five thousand) only**.

Thanks & Regards

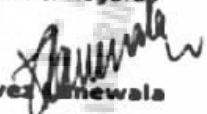
Parvez Anewala
(Director)



NAVI MUMBAI - INDIA

Pinnacle Industrial Controls Pvt. Ltd.

Regd. Office: J208, Ansa Ind. Estate, Saki Vihar Road, Andheri (E), Mumbai 400072. T. + 91 022 4228 1900

Factory & Warehouse: Gate No. 9, Building A/12, Haritar Complex, Opp. Dapode Weigh Bridge, Anjar Manali Road, Dapode, Bhiwandi, Thane 421302. T. + 91 2522 661917 / 04

E. info@pinnacle-controls.com | www.pinnacle-controls.com | CIN: U28120MH-2000PTC125236



GENERAL CODE OF CONDUCT

Employees are expected to maintain the highest standards of conduct and integrity in the performance of their duties and responsibilities. An employee who fails to conform to a reasonable standard of professional and personal behavior in carrying out assigned duties or who has a disregard for laws, rules, or regulations will face disciplinary action.

1. Any act which may be considered as misconduct in common parlance.
2. All Employees shall conduct business in compliance with all applicable laws and regulations of the particular District, State or Country.
3. All employees must protect our company's legality. They should comply with all environmental, safety and fair dealing laws. We expect employees to be ethical and responsible when dealing with our company's finances, products, partnerships and public image.
4. In case of ambiguity of the laws or their interpretation, legal advice will be sought. All required information will be made accessible to the Company's auditors and other authorized persons and government agencies. False or misleading entries, unrecorded funds or assets, or payments without appropriate supporting documentation and approval are strictly prohibited and violate Company policy and the Law. There shall be no willful omissions of any company transactions from the books and records, no advance income recognition and no hidden bank accounts and funds. No employee in any way will cause the company's accounts or other records to not clearly describe and properly state the true nature and timing of a business activity or transaction.
5. Fraud or the act or intent to cheat, trick, steal, deceive, or lie — is both dishonest and, in most cases, criminal. Intentional acts of fraud are subject to strict disciplinary action, including dismissal and possible civil and/or criminal action against the concerned Employee.
6. Some examples of Fraud include: Submitting false expense reports; Forging or altering checks; Misappropriation Of assets or misusing Company's property; Unauthorized handling or reporting of transactions; Inflating sales numbers by shipping inventory known to be defective or non-conforming; Making any entry on Company records or financial statements that is not accurate and in accordance with proper accounting standards
7. All Employees shall devote their time and their best efforts to promote the Company's business and may not without the prior written consent of the Company (and subject to any terms and conditions as may be imposed by the Company) engage or be interested in (whether directly or indirectly) in any other business, employment or vocation for monetary gain.

Pinnacle Industrial Controls Pvt. Ltd.

Regd. Office: J208, Arsa Ind Estate, Saki Vihar Road, Andheri (E), Mumbai 400072. T: +91 822 4228 1980

Factory & Warehouse: Gate No. 9, Building A/12, Haritar Complex, Opp. Dapode Weigh Bridge, Andheri-Mumbai Road, Dapoda, Bhamburda, Thane 421302. T: +91 2522 061917/04
E: info@pinnacle-controls.com | www.pinnacle-controls.com | CIN: U20120MH2000PTC125239

8. All employees should respect their colleagues. Employees should be friendly and collaborative. All employees must be open for communication with their colleagues, supervisors or team members. They should try not to disrupt the workplace or present obstacles to their colleagues' work. We won't allow any kind of discriminatory behavior, sexual harassment or victimization. Employees should conform with our equal opportunity policy in all aspects of their work, from recruitment and performance evaluation to interpersonal relations.
9. Employees are advised not to engage in any other business, commercial or investment activity that may conflict with their ability to perform their duties to the Company. Employees must also not engage in any other activity (cultural, political, recreational, and social) which could reasonably conflict with the Company's interests and interfere with the performance of their duties. All employees should treat our company's property, whether material or intangible, with respect and care.
10. Employees must not use any Company's property, information or position, or opportunities arising from these for personal gains or to compete with or to tarnish the image of the Company. Employees should not engage in any business activity, which could be detrimental to, or in competition with, the Company's any business activities even after working hours and on holidays.
11. Uses of electronics that threaten the integrity of the system, the privacy of others, or that are otherwise illegal, are hence forbidden. The Company reserves the right to access and monitor all messages and files on its system, including information regarding employee internet use, as and when deemed necessary and appropriate. The electronic resources shall be used in an effective, ethical and lawful manner. Users who receive or notice obscene or inappropriate messages are needed to report the same immediately to their immediate superior or HR manager. The Company will not be responsible for actions of employees deemed illegal with respect to the usage of electronic resources.
12. All employees should fulfill their job duties with integrity and respect toward customers, stakeholders and the community. Supervisors and managers mustn't abuse their authority. Likewise, we expect team members to follow team leaders' instructions and complete their duties with skill and in a timely manner. We encourage mentoring throughout our company.
13. Employees of the Company must maintain the confidentiality of confidential information entrusted to them by the Company or its suppliers or customers, except when disclosure is authorized by senior management or required by laws, regulations or legal proceedings. Confidential information includes all non-public information that might be of use to competitors of the Company, or harmful to the Company or its customers, if disclosed.
14. All Employees shall comply with the company health and safety norms as communicated to them from time to time. Employees shall bring to the management's attention any workplace safety or health hazard. In case if any employee has contracted any contagious disease he/she needs to inform the management immediately.
15. We expect employees to not abuse their employment benefits. This can refer to time off, insurance, facilities, subscriptions or other benefits our company offers.

16. All employees should read and follow our company policies. If they have any questions, they should ask their managers or the HR

Non-observance of this Policy shall be construed as misconduct that could warrant disciplinary action. The decision in this regard will lie with the Management, including the Team Leader and concerned HR Manager and shall be binding on the Employees. Disciplinary actions will vary depending on the violation.

Possible consequences include:

- Demotion.
- Suspension or termination for more serious offenses.
- Detraction of benefits for a definite or indefinite time.
- Dismissal
- Legal action will be taken in cases of corruption, theft, theft or sharing of company information, embezzlement or other unlawful behavior.

All queries and clarifications on the policy and procedures may be referred to the HR-Office

The above guidelines and code of conduct are to be followed by each employee of Pinnacle Industrial Controls Pvt. Ltd irrespective of his / her level and department. These guidelines, policies and code of conduct are designed to make sure that company and its employees carry out their responsibilities, ethically and honestly. All employees must follow these throughout their tenure at Pinnacle Industrial Controls Pvt. Ltd.

Our Company lays great emphasis on this code of conduct guidelines and believes that these are critical in ensuring a constructive and positive work environment here along with portraying a good image of the company to the outside world. Hence, we will not tolerate any violations and appropriate disciplinary action will be taken against any employee found to be violating these. Pinnacle Industrial Controls Pvt. Ltd management will decide on the nature of such disciplinary action on a case to case to basis depending on the severity of the violation.

AMENDMENTS

The Company reserves the rights to change/ amend / add /delete/ modify this Policy in whole or in part, at any time and this will be notified to all by email. An personal acknowledgement will not be taken after every amendment. The Employees should acknowledge that they will not be personally advised of any such change/ amendment / addition /deletion/ modification. The Employees are advised to check for any such change/ amendment / addition /deletion/ modification regularly. The Employees hereby unconditionally agree to all such changes / amendments / additions / deletions / modifications.

Parveen Lanewala
(Director)

I understand and agree _____

(Mohammed Faraz Shaikh)

Chapter 10

Reference

- Rashmi M. Kittali* and Ashok Sutagundar** Automation of Waste Segregation System using PLC
*Department of Electronics and Communication Engineering, Basaveshwar Engineering College, Bagalkot-587102, INDIA **Department of Electronics and Communication Engineering Basaveshwar Engineering College, Bagalkot-587102, INDIA (Received 28 September, 2016 Accepted 29 October, 2016)
- Durgesh Kumar Chaturvedi¹, Dr. Nagendra Tripathi², AUTOMATIC SEPARATION OF MUNICIPAL WASTE USING PLC AND SMART HOPPER 1M. Tech Scholar, Department of EE, Bhilai Institute of Technology, Durg, India, ²Associate Professor Department of EE, Bhilai Institute of Technology, Durg, India e-ISSN: 2395-0056 Volume: 06 Issue: 03 | Mar 2019 www.irjet.net p-ISSN: 2395-0072.
- Subhasini Dwivedi Michael Fernandes Rohit D'souza International Journal of Advanced Research in Computer Engineering Technology (IJARCET). A Review on PLC based Automatic Waste Segregation Volume 5 Issue 2, February 2016 ISSN: 2278 – 1323 All Rights Reserved © 2016 IJARCET r.
- Rahul Deshmukh, Chinmay Joshi, Yash Bachhav, Sachin More, Amit Mishra Sandip Institute of Technology Research Centre Material Segregation Waste Management using PLC. International Journal of Engineering Technology Science and Research, IJETSr www.ijetsr.com ISSN 2394 – 3386 Volume 5, Issue 3 March 2018 .
- Nitika Ghosh, Piyush Kumar, Shivam Bhardwaj, Vijay Singh Rana, Nishchal Verma, Published By: Blue Eyes Intelligence Engineering Retrieval Number: F61670486S19 Sciences Publication. Experimental Setup of Segregation of Industrial Waste using PLC. International Journal of Innovative Technology and Exploring Engineering (IJITEE) ISSN: 2278-3075, Volume-8 Issue-6S, April 2019.