

LIB

Engineering Drawings.

06/06/2013
May 2013

FE - Sem II
E. D.

ws-Con-2013-58

Con. 6946-13.

(REVISED COURSE)

GS-5568

(3 Hours)

[Total Marks : 60

N.B.: 1. Question NO 1 compulsory. Attempt any three out of remaining question.

2. All dimensions are in mm.

3. Assume suitable dimensions if necessary.

Q .1 (a) A circular plate of diameter 60 mm rolls without slipping along a straight line inclined at 30° to horizontal. Draw locus of point of its contact with the line if it completes one rotation. Name the curve. [06]

(b) Draw i) Front view. [04]

ii) Top View. [04]

iii) Insert all major dimensions. [01]

Refer Fig. No. 1 (Page 3)

Q .2 Draw i) Front view. [04]

ii) Sectional Top View. [05]

iii) R.H.S. View [04]

iv) Insert all major dimensions. [02]

Refer Fig. No. 2 (Page 3)

Q .3 A pentagonal pyramid side of base 30 mm and axis 60 mm long stands on an edge of base on H.P. The edge makes an angle of 45° with the V.P. Draw its projections if the apex is 40 mm above H.P. and nearer to the observer. [15]

[TURN OVER

Q. 4 (a) A cylindrical block of base diameter 80 mm and height 50 mm is resting on one of the base point on H.P. with axis inclined at 60° to H.P. Draw its projections. [06]

(b) Draw isometric projection using natural scale. Refer Fig. No. 3 [09]

Q. 5 A right circular vertical cone, base diameter 50 mm and axis 60 mm long is cut by an AIP and bisecting the axis. Draw Front View, Sectional Top View and True Shape of the Section if True Shape of the Section is an ellipse with major axis is 40 mm. What is the inclination of the cutting plane with H.P.? Also draw Development of Lateral Surface of remaining portion of the solid. [15]

Q. 6 (a) Top view and front view of a line AB, 70 mm long measures 55mm and 60mm respectively. Draw its projections if end A is 15 mm above H.P. and 20 mm in front of V.P. Determine its inclinations with H.P. and V.P. [09]

(b) Draw isometric projection using natural scale Refer Fig. No.4 [06]

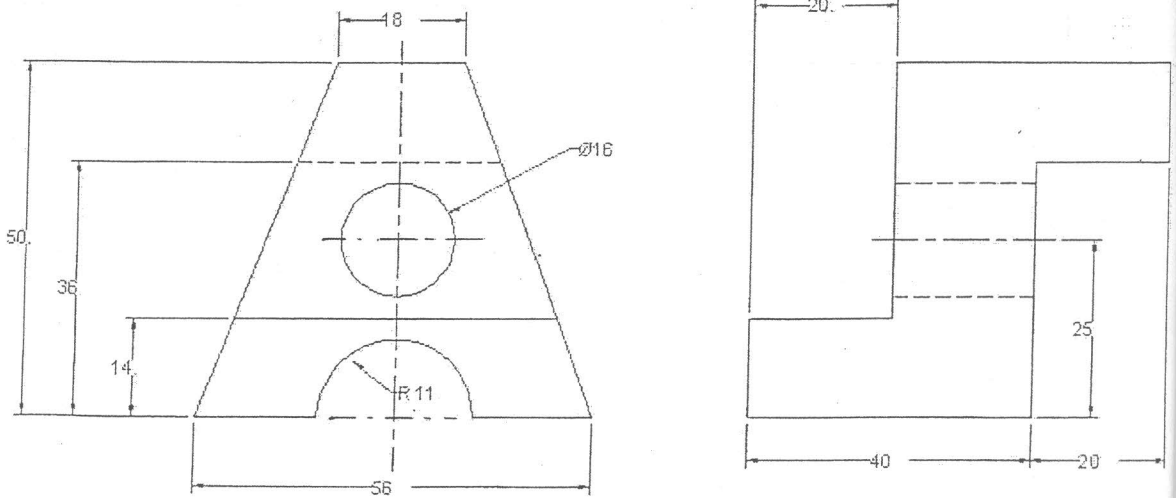

Figure 3(Q4, b)

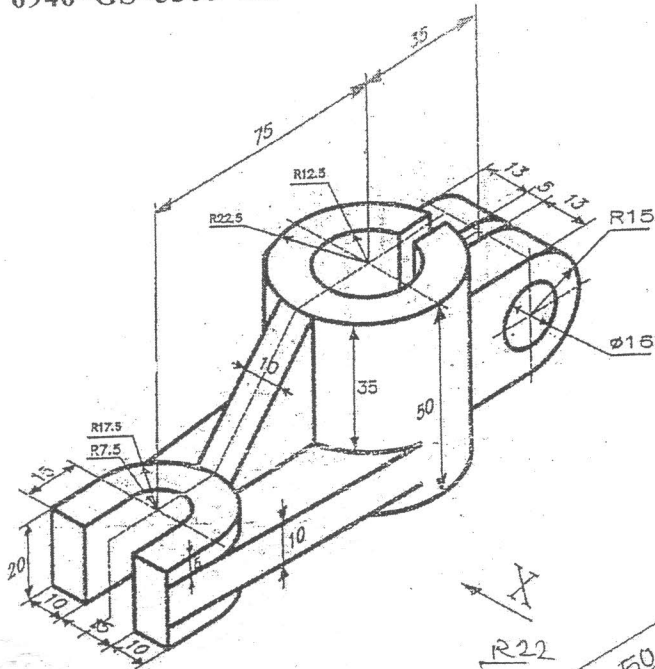

Figure 1 (Q1, b)

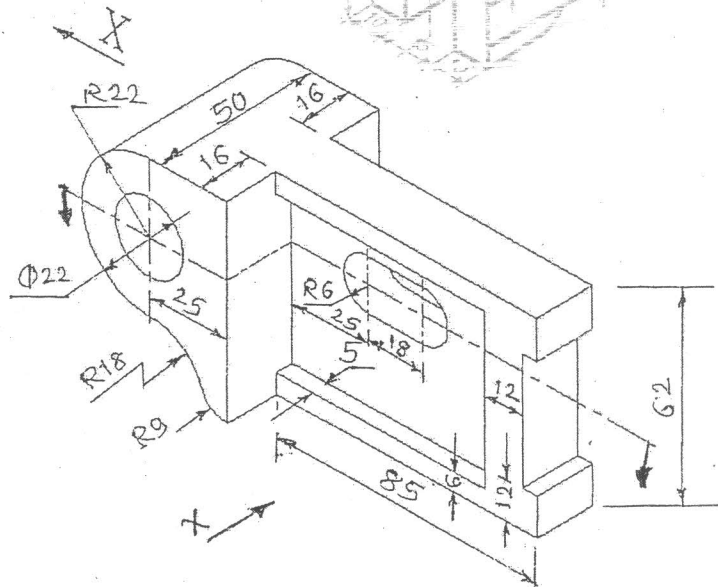

Figure 2, (Q. 2)

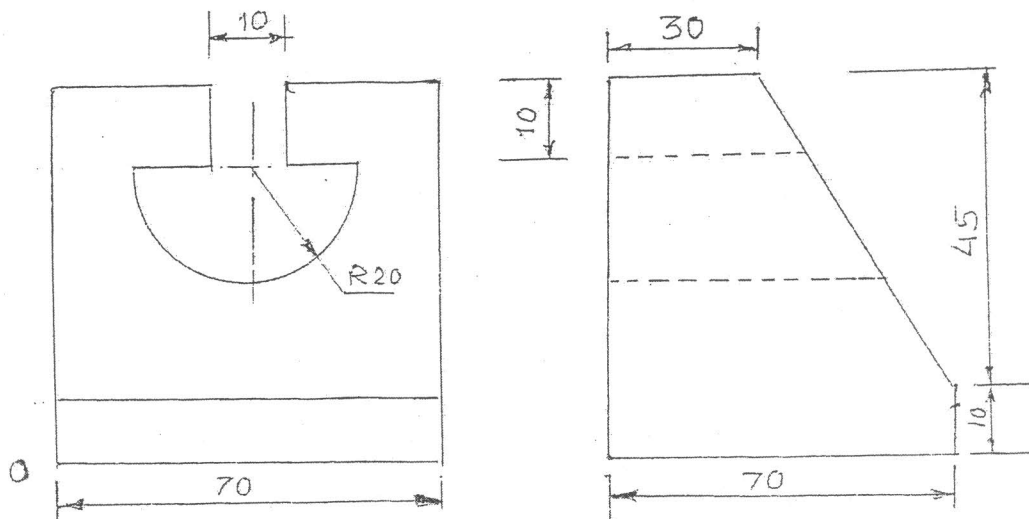

Figure No. 4, (Q6, b)