

QP Code : NP-17698

(3 Hours)

[Total Marks : 80

- N.B. : (1) Question No. 1 is Compulsory.
 (2) Solve any three questions from the remaining five questions.
 (3) Assume data if required.
 (4) Figures to the right indicate full marks.

1. (a) Using Source conversion, seduce the circuit shown in figure into single current source in parallel with single resistance. 3

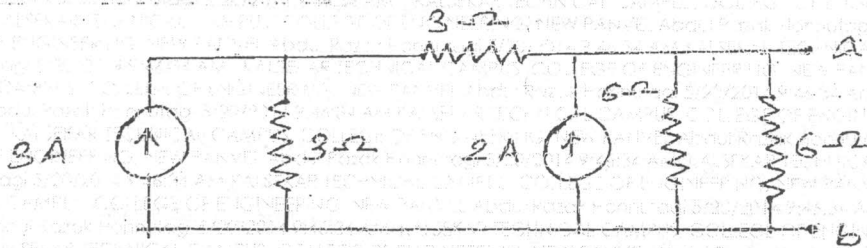

- (b) Derive the condition for maximum power transfer through the network. 3
 (c) An alternating current takes 3.375 ms to reach 15A for the first time after becoming instantaneously zero. The frequency of the current is 40 Hz. Find the Maximum value of the alternating current. 3
 (d) Derive the equation for resonance frequency $[f_r]$ in parallel resonance circuit. 3
 (e) Three identical coils each $[4.2 + j 5.6]$ ohm are connected in star Across 415V, 3 phase, 50Hz supply. determine (i) V_{ph} (ii) I_{ph} (iii) Power factor. 2
 (f) What are the losses in the transformer? Explain why the rating of transformer in KVA not in KW. 4
 (g) Draw complete V.I characteristics of a Diode. 2
2. (a) Determine the potential different V_{AB} for the given network. 6

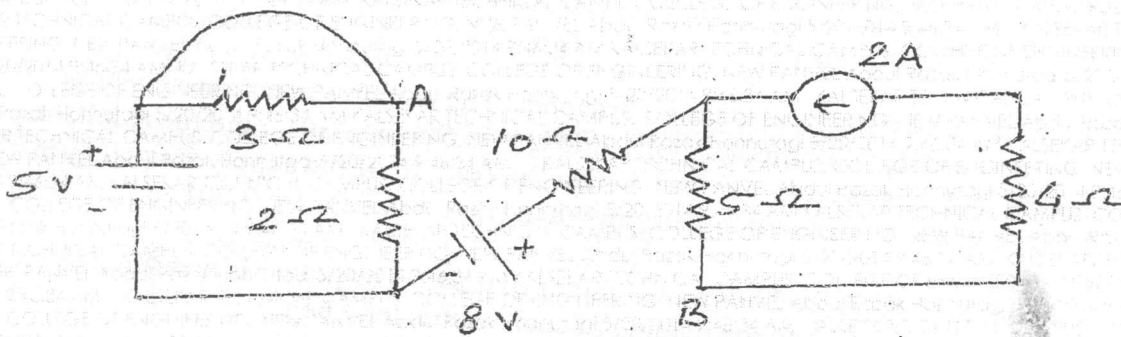

- (b) When a resistor and an inductor in series are connected to a 240V supply, a current of 3A flows lagging 37° behind the supply voltage, while voltage across inductor is 171 volt. Find the resistance of resistor, resistance & reactance of the inductor. 8

- (c) Draw phasor diagram of single phase transformer on resistive load [Unity power factor] and inductive load [lagging power factor]. 6
3. (a) Three similar coils, connected in star, take a total power of 18K.W at a power factor of 0.866 lagging from a three phase 400 volts, 50Hz system. Calculate the resistance and inductance of each coil. Also draw the phasor diagram showing the currents and voltages. 8
- (b) A 5 kvA 200/400 volt, 50Hz, single phase transformer gave the following test results. 6
- | | | | |
|---------------------|------|------|------|
| O.C. test [LV Side] | 200V | 0.7A | 60W |
| S.C. test [HV side] | 22V | 16V | 120W |
- (i) Draw the equivalent circuit of the transformer referred to LV side insert all parameters values.
- (ii) Efficiency at 0.9 power factor leading if operating at rated load.
- (c) What is function of filter in rectifier circuit? Draw circuit of rectifier with inductor filter. 2
- (d) Explain with circuit diagram working of CE configuration of BJT. 4
4. (a) Find an equivalent resistance between A and B. 7

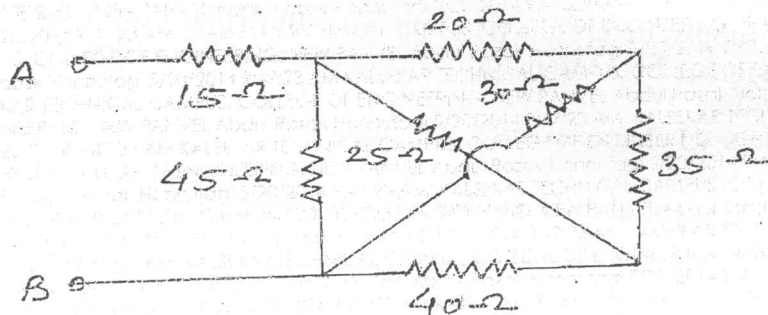

- (b) A circuit consists of three parallel branches. The branch currents are given as $i_1 = 10 \sin \omega t$, $i_2 = 20 \sin (\omega t + 60^\circ)$, and $i_3 = 75 \sin (\omega t - 30^\circ)$. Find the resultant current and express it in the form $i = I_m \sin (\omega t + \phi)$. if the supply frequency is 50Hz, calculate the resultant current when (i) $t = 0$, (ii) $t = 0.001$ sec. 5
- (c) A 3 phase, 10 KVA load has power factor of 0.342. The power is measured by two wattmeter method. Find the reading of each wattmeter when, 4
- (i) Power factor is leading
- (ii) Power factor is lagging.
- (d) Explain working of centre tap full wave rectifier with waveforms. 4

5. (a) Find the current through 60Ω resistance by using Thevenin's theorem.

8

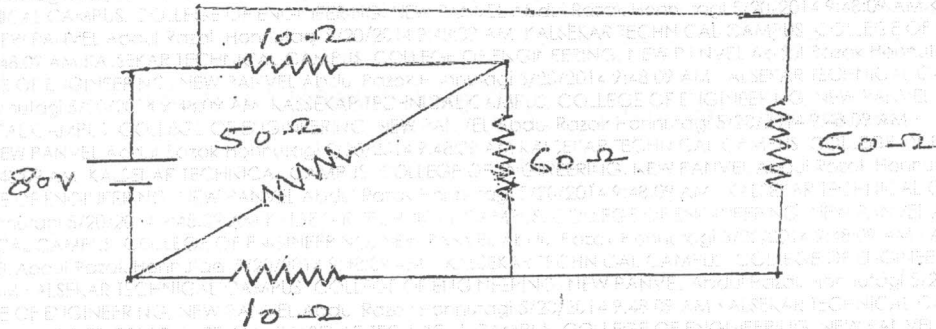

(b) Find current I_1 and I_2 shown in figure.

4

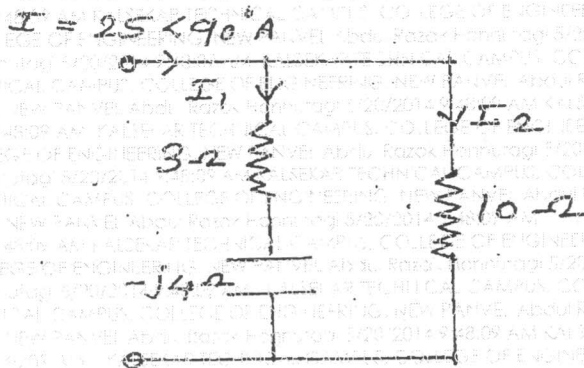

(c) A 50KVA, 4400/220 volt transformer has $R_1 = 3.45\Omega$, $R_2 = 0.009\Omega$. The reactance are $X_1 = 5.2\Omega$ and $X_2 = 0.015\Omega$. calculate for the transformer.

8

- (i) Full load currents on Primary and Secondary side,
- (ii) Equivalent resistance, reactances, impedances referred to primary side and secondary side, and
- (iii) Total copper loss using individual resistances and equivalent resistances.

6. (a) Find the current through 6Ω resistor using superposition theorem.

7

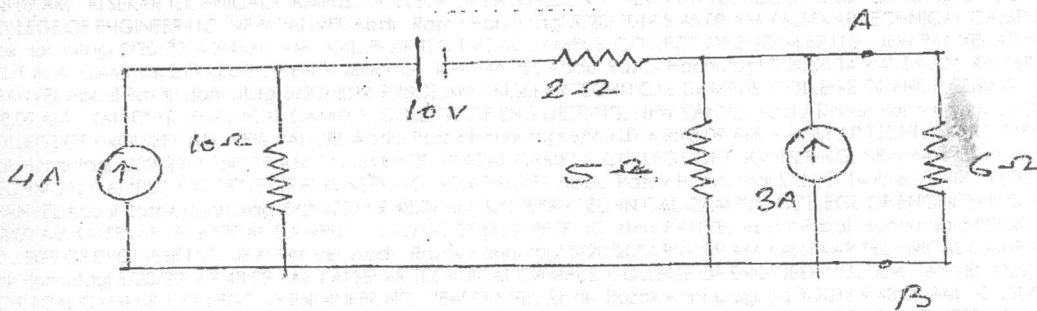

- (b) A coil of inductance 31.8mH with resistance of 12Ω is connected in parallel with a capacitor across 250 volts, 50Hz supply. Determine the value of capacitance, if no reactive current is taken from the supply. 7
- (c) Explain Measurement of three phase power using two wattmeter method. 6

EVS

(REVISED COURSE) QP Code : NP-17720**(2 Hours)****[Total Marks : 60**

- N.B. :** (1) Question No. 1 is **compulsory**.
 (2) Answer any **three** questions from Q. Nos. 2 to 6.
 (3) **Figures** to the **right** indicate **full marks**.
 (4) Draw **neat diagrams** wherever **necessary**.

1. Attempt any **five** from the following :- 15
 - (a) Explain how energy flows in a food chain.
 - (b) Explain the classification of ecosystem.
 - (c) What is "Photochemical Smog" ?
 - (d) What is the role of Ministry of Environment and Forest ?
 - (e) What do you understand by "Geothermal Energy" ? Explain.
 - (f) Explain the concept of Green Building.
 - (g) What do you mean by "e-pollution" ?

2. (a) Explain in detail the 3 Rs namely Reuse, Recovery and Recycle as control measures of sustainability. 5
 (b) Write a case study on "Minamata disease". 5
 (c) Draw a neat schematic diagram of Hydropower plant and brief its working. 5

3. (a) Draw a neat and labelled diagram of "Venturi Scrubber" and explain its working. 5
 (b) What type of Environmental clearances are required to set up and start an industrial unit ? 5
 (c) Explain the concept of "Carbon Credit". 5

4. (a) Discuss the global environmental crisis in brief.
 (b) What are the general powers of the central government stated in chapter-II of Environmental protection Act 1986 ? 5
 (c) What are the limitations of conventional sources of energy ? 5

5. (a) How are utilization of resources is made as per the carrying capacity ? 5
 (b) Explain solid waste management by "Land filling". 5
 (c) What are the limitations of conventional sources of energy ? 5

6. (a) Explain "Food chain" and "Food web". 5
 (b) How ozone is getting depleted from the atmosphere ? Explain with chemical reactions. 5
 (c) What is the role of technology w.r.t. environment and health ? 5

Con. 9279-14.

FE-sem I (Rev-CBSGS)
Engg. Mechanics

26.05.2014

(REVISED COURSE)

QP Code : NP-17702

(3 Hours)

[Total Marks : 80

N.B.1. Question No. 1 is Compulsory.

2. Answer any **three more** questions out of **remaining** questions.
3. Assume any suitable data wherever required but justify the same.
4. Figures to the right indicate full mark
5. Take $g = 9.81 \text{ m/s}^2$

Q1.

- a) Two concurrent forces P and Q acts at O such that their resultant acts along x-axis. Determine the magnitude of Q and hence the resultant. [4]

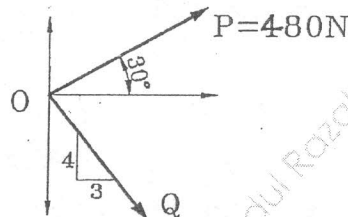

- b) A cylinder with 1500 N weight is resting in an unsymmetrical smooth groove as shown in figure. Determine the reactions at the points of contacts [4]

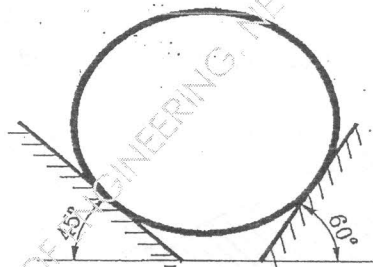

- c) Explain Angle of Friction, Angle of Repose and the relation between the two. [4]
- d) A sprinter in a 100 m race accelerates uniformly for the first 35 m and then runs with constant velocity. If the sprinter's time for the first 35 m is 5.4 seconds, determine his time for the race. [4]
- e) A motorist travelling at a speed of 90 kmph suddenly applies the brakes and comes to rest after skidding 100 m . Determine the time required for the car to stop and coefficient of kinetic friction between the tires and the road. [4]

[TURN OVER

Q2.a) A system of forces acting on a bell crank is as shown. Determine the magnitude, direction and the point of application of the resultant w.r.t 'O' [6]

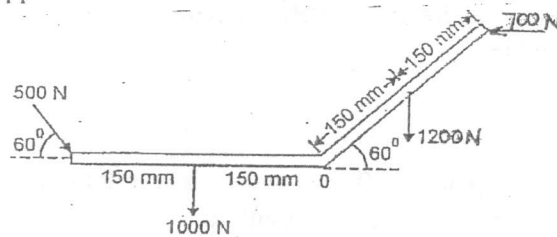

b) Two cylinders are kept in a channel as shown in figure. Determine the reactions at all the contact points A, B, C and D. Assume all surfaces smooth. [8]

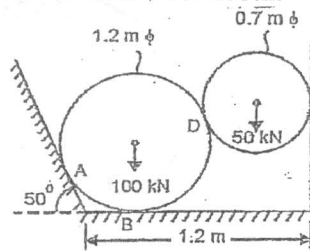

c) A ball of mass 'm' hits directly to a similar ball of mass 'm' which is at rest. The velocity of first ball after impact is zero. Half of the initial kinetic energy is lost in impact. Find coefficient of restitution. [6]

Q3.a) Determine the Centre of gravity of the shaded area. [8]

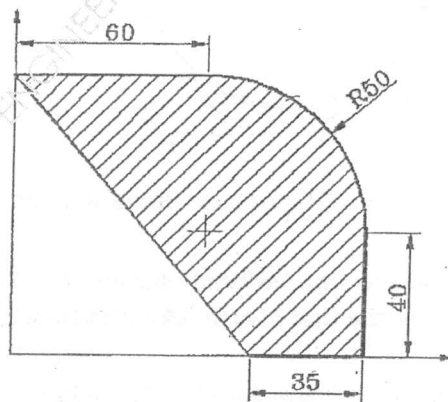

b) The lines of action of three forces concurrent at origin 'O' pass respectively through points A(-1,2,4), B(3,0,-3) and C(2,-2,4)m. The magnitude of forces are 40N, 10N and 30N respectively. Determine the magnitude and direction of their resultant. [6]

c) A 30N block is released from rest. It slides down a rough incline having coefficient of friction 0.25. Determine the maximum compression of the spring. [6]

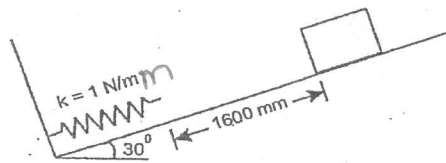

Q4.a) Find the support reaction at B and the load P, for the beam shown in figure if the reaction at support A is zero. [8]

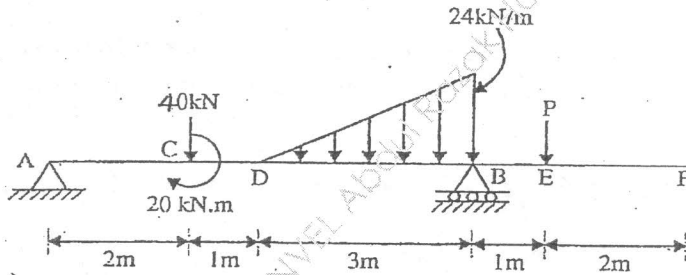

b) A gunman fires a bullet with a velocity of 100m/s, 50° upwards from the top of a hill 300m high to hit a bird. The bullet misses its target and finally lands on the ground. Calculate (a) the maximum height reached by the bullet above the ground (b) total time of flight (c) velocity with which the bullet hits the ground. [6]

c) In the mechanism shown the angular velocity of link AB is 5 rad/sec anticlockwise. At the instant shown, determine the angular velocity of link BC and velocity of piston C. [6]

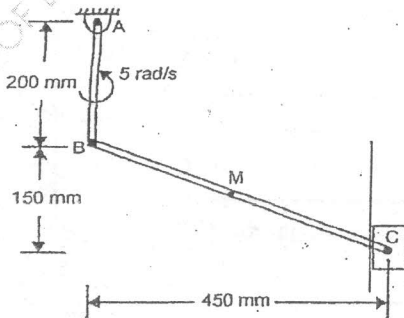

[TURN OVER

Q5.a) Determine the forces in members BC, CE and DE by method of sections and all other members by method of joints. Give the result in a table. [8]

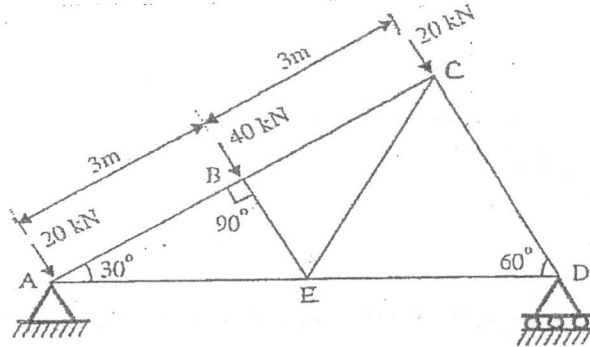

b) Due to slipping, points A and B on the rim of the disk have the velocities as shown in figure. Determine the velocities of the centre point C and point D on the rim at this instant. Take radius of disk 0.24m. [6]

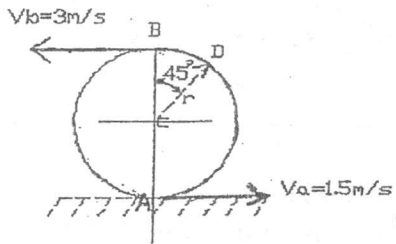

of disk 0.24m.

c) A particle moves in a straight line with a velocity-time diagram shown in figure. If $S = -25 \text{ m}$ at $t=0$, draw displacement-time and acceleration time diagrams for 0 to 24 seconds. [6]

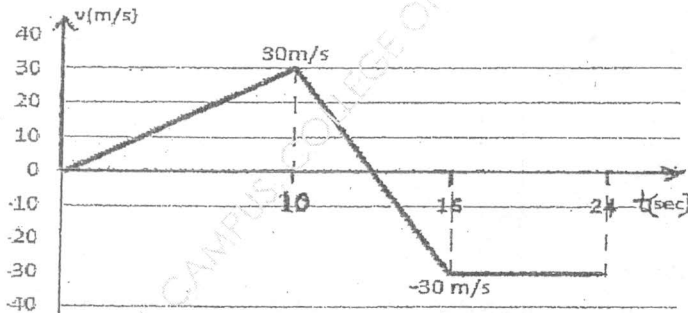

Q6.a) The mass of A is 23kg and mass of B is 36kg. The coefficient of friction are 0.4 between A and B, and 0.2 between ground and block B. Assume smooth drum.. Determine the maximum mass of M at impending motion. [8]

minimum

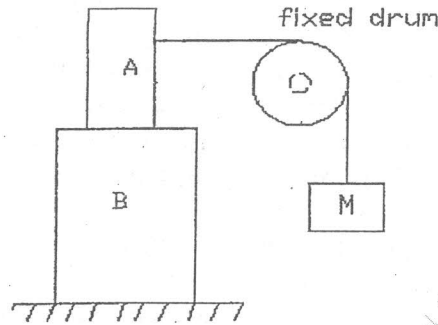

b) A force of 1200N acts along PQ, P(4,5,-2) and Q (-3,1,6)m. Calculate its moment about a point A(3,2,0) m [4]

c) A point moves along the path $y=x^2/3$ with a constant speed of 8m/s. What are the x and y components of the velocities when $x=3$. What is the acceleration of the point when $x=3$. [4]

d) A two step pulley supports two weights A=40N and B=60N as shown. Find the downward acceleration of A if radius of bigger pulley is double that of the smaller one. Neglect friction and inertia of pulley. [4]

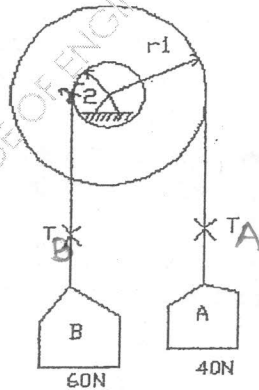

FE - sem I (Rev-CBSGS)
Applied Physics - I

30/05/2014

(REVISED COURSE)
(2 Hours)

QP Code : NP-17709
[Total Marks :60

- N.B.:— (1) Question no.1 is compulsory.
(2) Attempt any three questions from Q.2 to 6
(3) Use suitable data wherever required.
(4) Figures to the right indicate full marks.

1. Solve any five from the following:— 15
- (a) What is x-rays? Why the x-rays are preferred to study crystalline solid.
 - (b) Represent the following in a cubic unit cell (021), (123), [121]
 - (c) Find the miller indices of a set of parallel planes which makes intercepts in the ratio 3a:4b on the x and y axes and parallel to Z-axis.
 - (d) What is Fermi level and Fermi energy? Write Fermi-Dirac distribution function.
 - (e) Explain the concept of hole in a semiconductor.
 - (f) Draw the structure of quartz crystal and explain its various axes.
 - (g) State and explain ohm's law in magnetic circuit?
2. (a) Describe the formation of energy band in solid? Explain how it helps to classify the solids in to conductors, insulators and semiconductors with proper diagram. 8
- (b) Explain Diamond crystal structure with proper diagram and determine its APF? 7
3. (a) Derive the Bragg's law and describe the powder method to determine crystal structure of powdered specimen. 8
- (b) The magnetic field strength of copper is 10^6 ampere / metre. and magnetic susceptibility is -0.8×10^{-3} . Calculate magnetic flux density and magnetisation in copper. 7
4. (a) What is liquid crystal state of matter? Draw the diagram to describe molecular arrangement in their different phases? 5
- (b) Mention different types of polarizability in a dielectric? Explain electronic polarizability? 5
- (c) Calculate electron and hole concentration in intrinsic silicon at room temperature if its electrical conductivity is 4×10^{-4} mho/m. (mobility of electron = $0.14 \text{ m}^2/\text{v-s}$ & mobility of hole = $0.040 \text{ m}^2/\text{v-s}$) 5
5. (a) Explain with neat diagram construction and working of solar cell. 5
- (b) State the acoustic requirements of good auditorium. Explain how these requirements can be achieved. 5
- (c) If the x-rays of wavelength 1.549 \AA will be reflected from crystal having spacing of 4.255 \AA , calculate the smallest glancing angle and highest order of reflection that can be observed. 5
6. (a) Explain with neat diagram Hysteresis effect in ferromagnetic material. 5
- (b) Explain piezoelectric oscillator to produce USW? 5
- (c) Explain the formation of barrier potential in P-N Junction. 5

(REVISED COURSE)QP Code : **NP-17714**

(2 Hours)

[Total Marks : 60

- N.B. : (1) Question No. 1 is compulsory.
 (2) Answer any **three** questions from the remaining **five**.
 (3) All questions carry equal marks.
 (4) Atomic weights Ca = 40, Mg = 24, Fe = 56, Cl = 35.5, Na = 23, S = 32, H = 1, C = 12, O = 16

1. Solve any **five** :-

15

- (a) Give the principle of estimation of hardness of water using EDTA method (only equations).
 (b) Natural rubber needs to be vulcanised. Give reasons for the same.
 (c) What are the functions of a lubricant?
 (d) Give the preparation, properties and uses of dolomite bricks.
 (e) What is a condensed system? State the condensed phase rule equation.
 (f) Classify the following salts into temporary and permanent hardness causing salts and also calculate their calcium carbonate equivalents.
 (i) $\text{Ca}(\text{HCO}_3)_2$ - 16.2 mg/L
 (ii) MgSO_4 - 1.2 mg/L
 (iii) FeCl_2 - 12.7 mg/L
 (iv) NaCl - 94 mg/L
 (g) Name the various ingredients used in the compounding of plastics and give two examples of each.

2. (a) Calculate the quantity of pure lime and soda required for softening 50,000 litres of water containing the following salts per litre -
 $\text{Ca}(\text{HCO}_3)_2$ - 8.1 mg; $\text{Mg}(\text{HCO}_3)_2$ - 7.3 mg;
 CaSO_4 - 13.6 mg; MgSO_4 - 12.0 mg;
 NaCl - 4.7 mg; MgCl_2 - 23.75 mg.

6

- (b) Define (i) Phase (ii) Component (iii) Degrees of freedom. State the number of phases, components and the number of degrees of freedom for the following equilibrium.

$$\text{H}_2\text{O}_{(s)} \rightleftharpoons \text{H}_2\text{O}_{(l)} \rightleftharpoons \text{H}_2\text{O}_{(g)}$$

5

- (c) What are carbon nanotubes? Discuss the CVD method of preparation of CNT.

4

3. (a) Discuss the mechanism of boundary film lubrication.

6

- (b) What are thermoplastic polymers? Name any two thermoplastic polymer. Give the preparation, properties and uses of any one thermoplastic polymer.

5

- (c) Draw the phase diagram of one component water system. Explain triple point. 4
4. (a) Write short notes on any two :- 6
 (i) Glass transition temperature
 (ii) Conducting polymers.
 (iii) Polymers used in medicine and surgery.
- (b) With a neat diagram explain the principle of Ion- Exchange method of softening of water and also give the softening and regeneration reactions. 5
- (c) 3g of vegetable oil was mixed with 50ml of 0.5N KOH solution and heated for 1 hour. The mixture required 19ml of 0.5N HCl. The blank titration reading was 49ml. Find the saponification value of the oil sample. 4
5. (a) Name the raw materials necessary for the manufacture of portland cement. Draw a neat labelled diagram of the rotary kiln and write the chemical reactions alongwith the temperature. Also mention the functions of Alumina and gypsum in cement. 6
- (b) What is moulding? Explain with the help of a neat diagram Extrusion moulding of an insulated cable. 5
- (c) The hardness of 50,000 litres of a sample of water was removed by passing it through a zeolite softener. The softener required 200 litres of NaCl solution containing 125g/L of NaCl for regeneration. Calculate the hardness of the sample of water. 4
6. (a) (i) Define and explain the significance of BOD and COD. 6
 (ii) Discuss reverse osmosis.
- (b) Give the preparation and uses of 5
 (i) Kevlar
 (ii) Polyurethane
- (c) Write note on any two :- 4
 (i) Acid value of oil.
 (ii) Flash and fire point.
 (iii) Semi solid lubricant.
-

37

EM - SEM-I
(CBSGS)

28/05/2014

Bachchan

(REVISED COURSE)

QP Code : NP-17702

2013-14
(ATKT)

(3 Hours)

[Total Marks : 80

N.B.1. Question No. 1 is Compulsory.

2. Answer any **three more** questions out of **remaining** questions.
3. Assume any suitable data wherever required but justify the same.
4. Figures to the right indicate full mark
5. Take $g = 9.81 \text{ m/s}^2$

Q1.

- a) Two concurrent forces P and Q acts at O such that their resultant acts along x-axis. Determine the magnitude of Q and hence the resultant. [4]

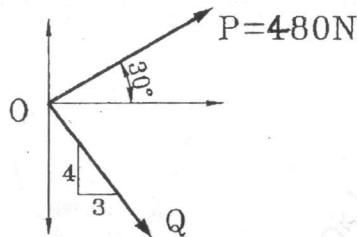

- b) A cylinder with 1500 N weight is resting in an unsymmetrical smooth groove as shown in figure. Determine the reactions at the points of contacts [4]

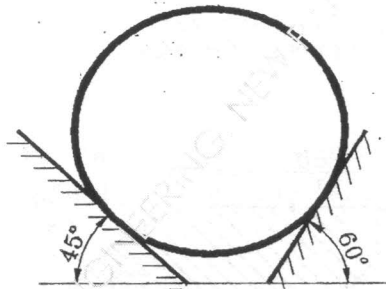

- c) Explain Angle of Friction, Angle of Repose and the relation between the two. [4]
- d) A sprinter in a 100 m race accelerates uniformly for the first 35 m and then runs with constant velocity. If the sprinter's time for the first 35 m is 5.4 seconds, determine his time for the race. [4]
- e) A motorist travelling at a speed of 90 kmph suddenly applies the brakes and comes to rest after skidding 100 m . Determine the time required for the car to stop and coefficient of kinetic friction between the tires and the road. [4]

[TURN OVER

Q2.a) A system of forces acting on a bell crank is as shown. Determine the magnitude, direction and the point of application of the resultant w.r.t 'O' [6]

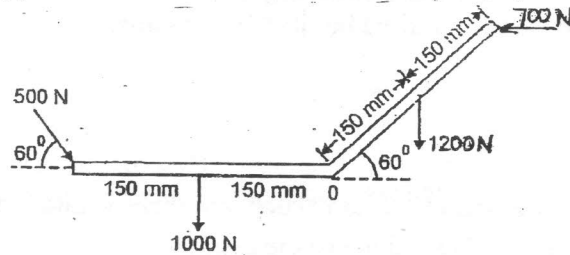

b) Two cylinders are kept in a channel as shown in figure. Determine the reactions at all the contact points A, B, C and D. Assume all surfaces smooth. [8]

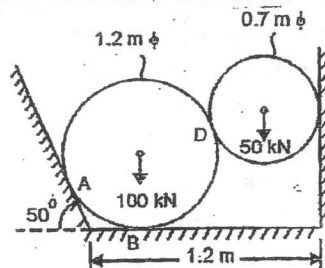

c) A ball of mass 'm' hits directly to a similar ball of mass 'm' which is at rest. The velocity of first ball after impact is zero. Half of the initial kinetic energy is lost in impact. Find coefficient of restitution. [6]

Q3.a) Determine the Centre of gravity of the shaded area. [8]

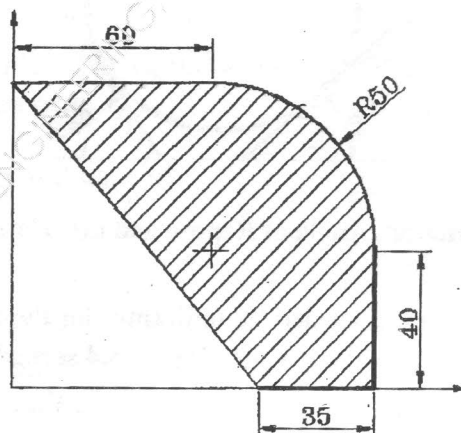

b) The lines of action of three forces concurrent at origin 'O' pass respectively through points A(-1,2,4), B(3,0,-3) and C(2,-2,4)m. The magnitude of forces are 40N, 10N and 30N respectively. Determine the magnitude and direction of their resultant. [6]

c) A 30N block is released from rest. It slides down a rough incline having coefficient of friction 0.25. Determine the maximum compression of the spring. [6]

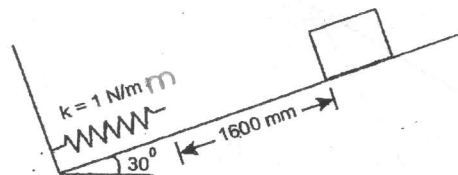

Q4.a) Find the support reaction at B and the load P, for the beam shown in figure if the reaction at support A is zero. [8]

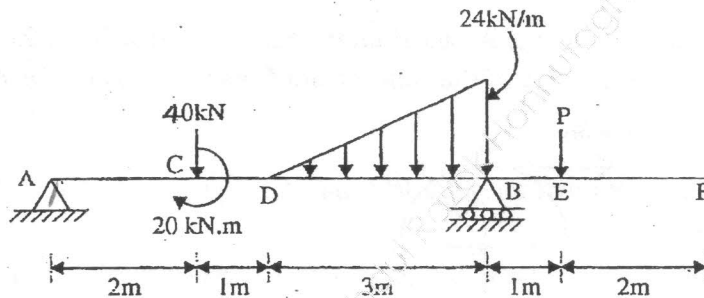

b) A gunman fires a bullet with a velocity of 100m/s, 50° upwards from the top of a hill 300m high to hit a bird. The bullet misses its target and finally lands on the ground. Calculate (a) the maximum height reached by the bullet above the ground (b) total time of flight (c) velocity with which the bullet hits the ground. [6]

c) In the mechanism shown the angular velocity of link AB is 5 rad/sec anticlockwise. At the instant shown, determine the angular velocity of link BC and velocity of piston C. [6]

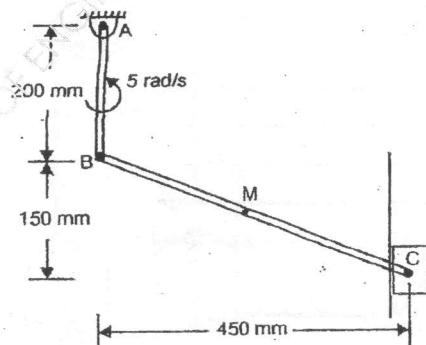

[TURN OVER

[TURN

Q5.a) Determine the forces in members BC, CE and DE by method of sections and all other members by method of joints. Give the result in a table. [8]

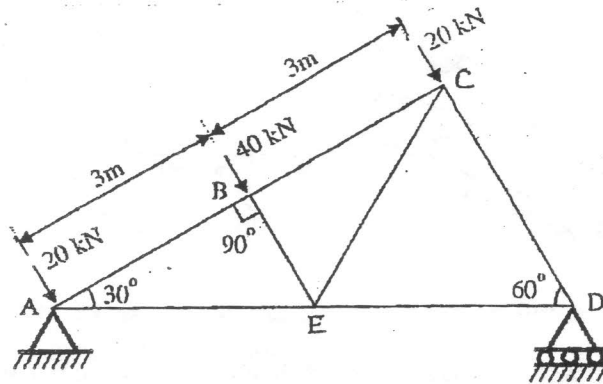

b) Due to slipping, points A and B on the rim of the disk have the velocities as shown in figure. Determine the velocities of the centre point C and point D on the rim at this instant. Take radius

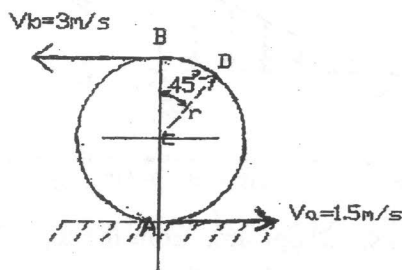

of disk 0.24m.

[6]

c) A particle moves in a straight line with a velocity-time diagram shown in figure. If $S = -25m$ at $t=0$, draw displacement-time and acceleration time diagrams for 0 to 24 seconds. [6]

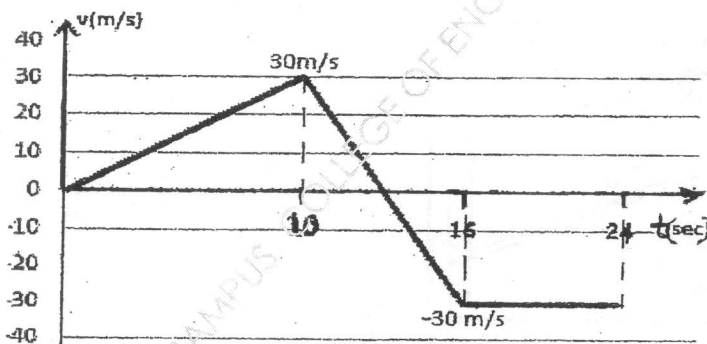

Q6.a) The mass of A is 23kg and mass of B is 36kg. The coefficient of friction are 0.4 between A and B, and 0.2 between ground and block B. Assume smooth drum.. Determine the maximum mass of M at impending motion. [8]

minimum

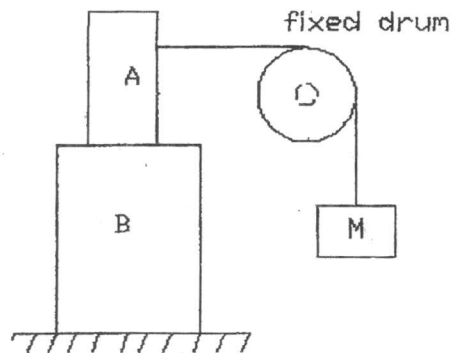

b) A force of 1200N acts along PQ, P(4,5,-2) and Q (-3,1,6)m. Calculate its moment about a point A(3,2,0) m [4]

c) A point moves along the path $y=x^2/3$ with a constant speed of 8m/s. What are the x and y components of the velocities when $x=3$. What is the acceleration of the point when $x=3$. [4]

d) A two step pulley supports two weights A=40N and B=60N as shown. Find the downward acceleration of A if radius of bigger pulley is double that of the smaller one. Neglect friction and inertia of pulley. [4]

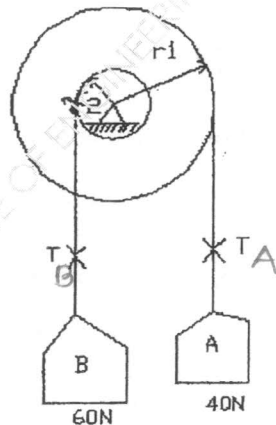

I (REV)/APPLIED MATHS/AM-I/ May 2014 Exam

013-14
(ATCT)

13/05/2014

(REVISED COURSE)

Q P Code : NP-17690

(3 Hours)

[Total Marks : 80

- N.B. : (1) Questions No. 1 is compulsory.
(2) Attempt any three from the remaining questions.
(3) Assume suitable data if necessary.

1. (a) Prove that $\text{Sech}^{-1}(\sin\theta) = \log\left(\cot\frac{\theta}{2}\right)$ 3
- (b) If $x = \cos\theta - r\sin\theta$, $y = \sin\theta + r\cos\theta$ 3
 prove that $\frac{dr}{dx} = \frac{x}{r}$
- (c) If $x = e^V \sec u$, $y = e^V \tan u$ 3
 find $J\left(\frac{u, v}{x, y}\right)$
- (d) If $y = \sin px + \cos px$ 3
 Prove that $y_n = p^n [1 + (-1)^n \sin 2px]^{\frac{1}{2}}$
- (e) Find the series expansion of $\log(1+x)$ in powers of x . Hence prove that 4
 $\log x = (x-1) - \frac{1}{2}(x-1)^2 + \frac{1}{3}(x-1)^3 - \dots$
- (f) If 'A' is skew-symmetric matrix of odd order then prove that it is singular. 4
2. (a) Show that the roots of the equation $(x+1)^6 + (x-1)^6 = 0$ are given by 6
 $-i \cot\left(\frac{2n+1}{12}\pi\right)$, $n=0,1,2,3,4,5$.
- (b) Find two non-singular matrices P & Q such that PAQ is in normal form where 6

$$A = \begin{bmatrix} 1 & 2 & 3 & -4 \\ 2 & 1 & 4 & -5 \\ -1 & -5 & -5 & 7 \end{bmatrix}$$
 Also find rank of A.
- (c) If $x + y = 2e^\theta \cos\phi$, $x - y = 2ie^\theta \sin\phi$ & u is a function of x & y the prove that 8

$$\frac{\partial^2 u}{\partial \theta^2} + \frac{\partial^2 u}{\partial \phi^2} = 4xy \frac{\partial^2 u}{\partial x \partial y}$$

3. (a) Find the value of λ for which the equations $x_1 + 2x_2 + x_3 = 3$, $x_1 + x_2 + x_3 = \lambda$, $3x_1 + x_2 + 3x_3 = \lambda^2$ has a solution & solve them completely for each value of λ . 6 6.
- (b) Divide 24 into three parts such that the product of the first, square of the second & cube of the third is maximum. 6
- (c) (i) If $\operatorname{cosec}\left(\frac{\pi}{4} + ix\right) = u + iv$ prove that $(u^2 + v^2)^2 = 2(u^2 - v^2)$ 4
- (ii) Prove that $\tan\left(i \log\left(\frac{a - ib}{a + ib}\right)\right) = \frac{2ab}{a^2 - b^2}$ 4
4. (a) Show that $\frac{\partial(u, v)}{\partial(x, y)} = 6r^3 \sin 2\theta$ given that $u = x^2 - y^2$, $v = 2x^2 - y^2$ & $x = r \cos\theta$, $y = r \sin\theta$. 6
- (b) If $\alpha = 1 + i$, $\beta = 1 - i$ & $\cot \theta = x + 1$ prove that $(x + \alpha)^n + (x + \beta)^n = (\alpha + \beta) \cos n\theta \operatorname{cosec}^n \theta$. 6
- (c) Using Gauss-seidel method, solve the following system of equations upto 3rd iteration. 8
- $$\begin{aligned} 5x - y &= 9 \\ -x + 5y - z &= 4 \\ -y + 5z &= -6 \end{aligned}$$
5. (a) Using De-Moivre's theorem, prove that 6
- $$\frac{\sin 6\theta}{\sin \theta} = 16 \cos^4 \theta - 16 \cos^2 \theta + 3$$
- (b) Expand $\frac{x}{e^x - 1}$ in powers of x . 6
- Hence prove that $\frac{x}{2} \left[\frac{e^x + 1}{e^x - 1} \right] = 1 + \frac{1}{12} x^2 - \frac{1}{720} x^4 + \dots$
- (c) If $y = \frac{\sin^{-1} x}{\sqrt{1 - x^2}}$ 8
- prove that $(1 - x^2)y_{n+2} - (2n + 3)xy_{n+1} - (n + 1)^2 y_n = 0$. Hence find $y_n(0)$

May 2014 Exam

FEI (Rev) AM-I

13/05/2014

Q P Code : NP-17690

3

6. (a) Examine the linear dependence or independence of vectors $(1, 2, -1, 0)$, $(1, 3, 1, 3)$, $(4, 2, 1, -1)$ & $(6, 1, 0, -5)$ 6

(b) If $u = f\left(\frac{x-y}{xy}, \frac{z-x}{xz}\right)$ prove that 6

$$x^2 \frac{\partial u}{\partial x} + y^2 \frac{\partial u}{\partial y} + z^2 \frac{\partial u}{\partial z} = 0$$

(c) (i) Fit a straight line to the following data with x - as independent variable. 4

X : 1965 1966 1967 1968 1969

Y : 125 140 165 195 200

(ii) Evaluate $\lim_{x \rightarrow 0} (1 + \tan x)^{\cot x}$ 4

I (REV)/APPLIED MATHS/AM-I/ May 2014 Exam

13/05/2014

(REVISED COURSE)

Q P Code : NP-17690

(3 Hours)

[Total Marks : 80

- N.B. : (1) Questions No. 1 is compulsory.
 (2) Attempt any three from the remaining questions.
 (3) Assume suitable data if necessary.

1. (a) Prove that $\text{Sech}^{-1}(\sin\theta) = \log\left(\cot\frac{\theta}{2}\right)$ 3
- (b) If $x = \cos\theta - r\sin\theta$, $y = \sin\theta + r\cos\theta$ 3
 prove that $\frac{dr}{dx} = \frac{x}{r}$
- (c) If $x = e^V \sec u$, $y = e^V \tan u$ 3
 find $J\left(\frac{u, v}{x, y}\right)$
- (d) If $y = \sin px + \cos px$ 3
 Prove that $y_n = p^n [1 + (-1)^n \sin 2px]^{\frac{1}{2}}$
- (e) Find the series expansion of $\log(1+x)$ in powers of x . Hence prove that 4
 $\log x = (x-1) - \frac{1}{2}(x-1)^2 + \frac{1}{3}(x-1)^3 - \dots$
- (f) If 'A' is skew-symmetric matrix of odd order then prove that it is singular. 4
2. (a) Show that the roots of the equation $(x+1)^6 + (x-1)^6 = 0$ are given by 6
 $-i \cot\left(\frac{2n+1}{12}\pi\right)$, $n=0,1,2,3,4,5$.
- (b) Find two non-singular matrices P & Q such that PAQ is in normal form where 6
- $$A = \begin{bmatrix} 1 & 2 & 3 & -4 \\ 2 & 1 & 4 & -5 \\ -1 & -5 & -5 & 7 \end{bmatrix}$$
- Also find rank of A.
- (c) If $x + y = 2e^{\theta} \cos\phi$, $x - y = 2ie^{\theta} \sin\phi$ & u is a function of x & y the prove that 8

$$\frac{\partial^2 u}{\partial \theta^2} + \frac{\partial^2 u}{\partial \phi^2} = 4xy \frac{\partial^2 u}{\partial x \partial y}$$

3. (a) Find the value of λ for which the equations $x_1 + 2x_2 + x_3 = 3$, $x_1 + x_2 + x_3 = \lambda$, $3x_1 + x_2 + 3x_3 = \lambda^2$ has a solution & solve them completely for each value of λ . 6 6.
- (b) Divide 24 into three parts such that the product of the first, square of the second & cube of the third is maximum. 6
- (c) (i) If $\operatorname{cosec}\left(\frac{\pi}{4} + ix\right) = u + iv$ prove that $(u^2 + v^2)^2 = 2(u^2 - v^2)$ 4
- (ii) Prove that $\tan\left(i \log\left(\frac{a - ib}{a + ib}\right)\right) = \frac{2ab}{a^2 - b^2}$ 4
4. (a) Show that $\frac{\partial(u, v)}{\partial(x, y)} = 6r^3 \sin 2\theta$ given that $u = x^2 - y^2$, $v = 2x^2 - y^2$ & $x = r \cos\theta$, $y = r \sin\theta$. 6
- (b) If $\alpha = 1 + i$, $\beta = 1 - i$ & $\cot \theta = x + 1$ prove that $(x + \alpha)^n + (x + \beta)^n = (\alpha + \beta) \cos n\theta \operatorname{cosec}^n \theta$. 6
- (c) Using Gauss-seidel method, solve the following system of equations upto 3rd iteration. 8
- $$\begin{aligned} 5x - y &= 9 \\ -x + 5y - z &= 4 \\ -y + 5z &= -6 \end{aligned}$$
5. (a) Using De-Moivre's theorem, prove that 6
- $$\frac{\sin 6\theta}{\sin \theta} = 16 \cos^4 \theta - 16 \cos^2 \theta + 3$$
- (b) Expand $\frac{x}{e^x - 1}$ in powers of x . 6
- Hence prove that $\frac{x}{2} \left[\frac{e^x + 1}{e^x - 1} \right] = 1 + \frac{1}{12} x^2 - \frac{1}{720} x^4 + \dots$
- (c) If $y = \frac{\sin^{-1} x}{\sqrt{1 - x^2}}$ 8
- prove that $(1 - x^2)y_{n+2} - (2n + 3)xy_{n+1} - (n + 1)^2 y_n = 0$. Hence find $y_n(0)$

May 2014 Exam

FE I (Rev) AM-I

13/05/2014

Q P Code : NP-17690

3

- 6 (a) Examine the linear dependence or independence of vectors $(1, 2, -1, 0)$, $(1, 3, 1, 3)$, $(4, 2, 1, -1)$ & $(6, 1, 0, -5)$ 6

- 6 (b) If $u = f\left(\frac{x-y}{xy}, \frac{z-x}{xz}\right)$ prove that 6

$$x^2 \frac{\partial u}{\partial x} + y^2 \frac{\partial u}{\partial y} + z^2 \frac{\partial u}{\partial z} = 0$$

- 4 (c) (i) Fit a straight line to the following data with x - as independent variable. 4

X : 1965 1966 1967 1968 1969

Y : 125 140 165 195 200

- 6 (ii) Evaluate $\lim_{x \rightarrow 0} (1 + \tan x)^{\cot x}$ 4
-