

# Radio-over-Fiber System Using Photonic Active Integrated Antennas (PhAIAs)

<sup>1</sup>Awab Fakh, <sup>2</sup>Jovita Serrao

<sup>1</sup>Anjuman-I-Islamic Kalsekar College of Engineering, Mumbai, India

<sup>2</sup>St. Francis Institute of Technology, Mumbai, India

## Abstract

There is much current interest in low-cost radio-over-fiber (RoF) systems for distribution of mobile-phone and WiFi signals within buildings. In such systems the link gain and packaging cost will be critical. This report describes a low cost scheme for implementing in-building distributed antenna systems using the Photonic Active Integrated Antenna (PhAIA) concept, whereby photonic devices are integrated directly with planar antennas. It is an extension to Active-Integrated-Antenna (AIA) concept from microwave engineering field. The fact that the photonic device and antenna are highly integrated means that very efficient impedance matching can be achieved, which can lead to improved link gain. It could also lead to much reduce packaging and fabrication costs.

## Keywords

Radio-over-Fiber, Vertical Cavity Surface Emitting Lasers (VCSELs), Photodiodes, Photonic Antenna, WLAN.

## I. Introduction

Wireless communication has experienced tremendous growth in the last decade. Apart from mobile telephone communications, Wireless Local Area Networks (WLANs), have also experienced phenomenal growth. The rapid proliferation of WLAN hotspots in public places, such as airport terminals has been astounding. In fact WLANs have now made their way into homes, riding on the back of xDSL and cable access modems, which are now integrated with WLAN Radio Access Points (RAPs). The rapid growth of wireless communications is mainly attributed to their ease of installation in comparison to fixed networks [1]. Wireless World Research Forum

(WWRF) states 7 trillion wireless devices serving 7 billion people in 2017 [2]. This essentially means that the entire world population will be served by wirelessly communicating devices. Therefore, the future wireless devices will have strict performance requirements such as wide bandwidth, high efficiency, high speed and dramatic reduction in size and weight.

Radio-over-Fiber technology achieves the simplification of the BSs/RAPs (referred to as Remote Antenna Units RAUs) through consolidation of radio system functionalities at a centralised headend, which are then shared by multiple RAUs.

Section II discusses the Radio-over-Fiber technology for distributing RF signals over fiber. The section reviews the principle of operation, benefits, limitations and applications of the technology. Chapter III describes the RoF system. The section reviews the full duplex RoF system and the various components of this system. In section IV, photonic active integrated antenna is described with a detail explanation of all the characteristics. Bidirectional RoF link both in the adhoc and infrastructure mode is discussed in section V. Section VI discusses photonic active integrated antenna array. The paper ends with section VII, which includes the summary and the future scope of RoF systems.

## II. Radio-over-Fiber Technology

Radio-over-Fiber (RoF) technology entails the use of optical fiber

links to distribute RF signals from a central location (head-end) to Remote Antenna Units (RAUs) [2]. RoF makes it possible to centralise the RF signal processing functions in one shared location (head-end), and then to use optical fiber, which offers low signal loss (0.3 dB/km for 1550 nm, and 0.5 dB/km for 1310 nm wavelengths) to distribute the RF signals to the RAUs, as shown in fig. 1.

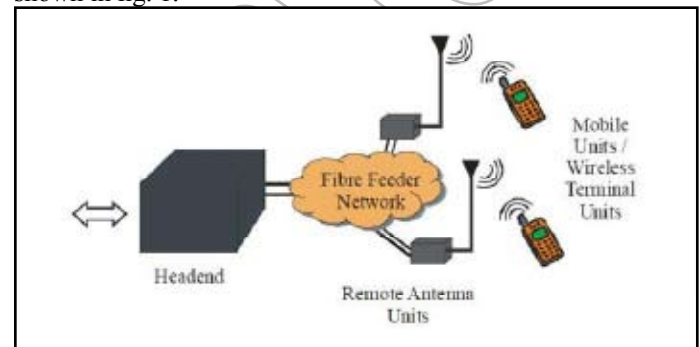

Fig. 1: Radio-over-Fiber System Concept [1]

One of the pioneer RoF system implementations is depicted in fig. 2. Such a system may be used to distribute GSM signals, for example. The RF signal is used to directly modulate the laser diode in the central site (head-end). The resulting intensity modulated optical signal is then transported over the length of the fiber to the BS (RAU). At the RAU, the transmitted RF signal is recovered by direct detection in the PIN photodetector. The signal is then amplified and radiated by the antenna. The uplink signal from the Mobile Unit (MU) is transported from the RAU to the head-end in the same way.

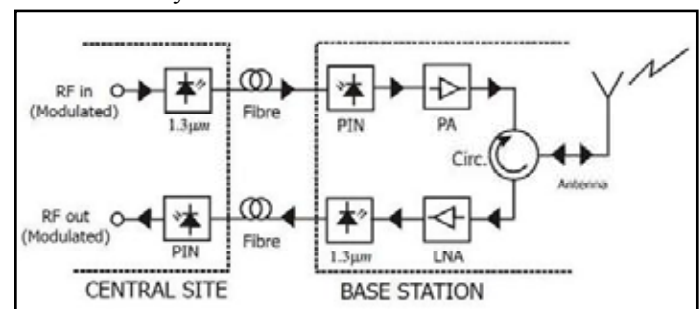

Fig. 2: 900 MHz Fiber Radio System [3]

Some of the advantages and benefits of the RoF technology compared with electronic signal distribution are low attenuation loss, large bandwidth, immunity to radio interference, easy installation and maintenance. However this system has certain limitations as well. Since RoF involves analogue modulation, and detection of light, it is fundamentally an analogue transmission system. Therefore, signal impairments such as noise and distortion, which are important in analogue communication systems, are important in RoF systems as well. These impairments tend to limit the Noise Figure (NF) and Dynamic Range (DR) of the RoF links. The main applications of RoF technology include in-building distribution of wireless signals, access to dead zones and

fiber-to-the-antenna (FTTA).

### III. Radio-over-Fiber System

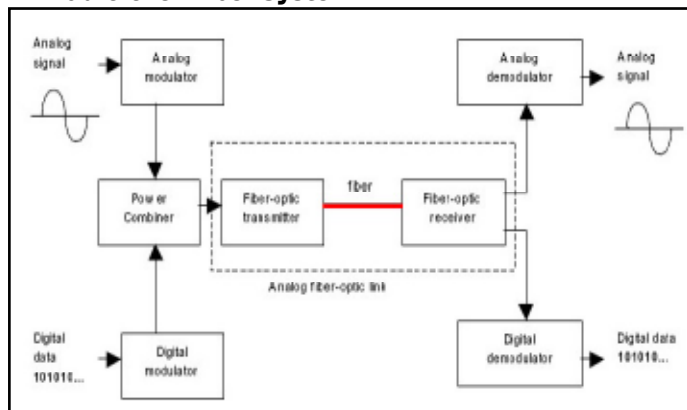

Fig. 3: Basic RoF Architecture [5]

Radio over Fiber technology (RoF), an integration of wireless and fiber optic networks, is an essential technology for the provision of untethered access to broadband wireless communications in a range of applications including last mile solutions, extension of existing radio coverage and capacity, and backhaul. The well known advantages of optical fiber as a transmission medium such as low loss, light weight, large bandwidth characteristics, small size and low cable cost make it the ideal and most flexible solution for efficiently transporting radio signals to remotely located antenna sites in a wireless network [5]. In addition to its transmission properties, the insensitivity of fiber optic cables to electromagnetic radiation is a key benefit in their implementation as the backbone of a wireless network. The traditional link between the radio base station (RBS) and the antenna has previously been a copper coaxial cable. To use an optical fiber cable instead, makes both design of new sites, as well as the physical deployment of the hardware, much easier.

Fig. 3 shows a typical RF signal (modulated by analog or digital modulation techniques) being transported by an analog fiber optic link. The RF signal may be baseband data, modulated IF, or the actual modulated RF signal to be distributed. The RF signal is used to modulate the optical source in transmitter. The resulting optical signal is launched into an optical fiber. At the other end of the fiber, we need an optical receiver that converts the optical signal to RF again. The generated electrical signal must meet the specifications required by the wireless application be it GSM, UMTS, wireless LAN, WiMax or other.

### IV. Photonic Active Integrated Antennas (PhAIAs)

The PhAIA concept is the intimate integration of photonic devices with antennas [6, 13]; it is an extension to the well known Active Integrated Antenna (AIA) concept from microwave engineering field. The fact that the photonic device and antenna are highly integrated means that very efficient impedance matching can be achieved, which can lead to improved link gain. It could also lead to much reduced packaging and fabrication costs.

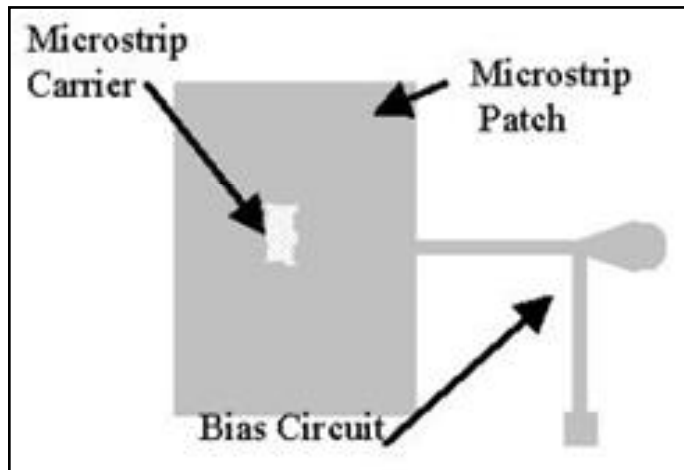

Fig. 4: Front View of PhAIA showing layout of microstrip patch, bias network and photonic device carrier mounted on the reverse side [13]

Fig. 4 shows a front view of PhAIA showing layout of microstrip patch, bias network and photonic device carrier mounted on the reverse side. The antenna is a standard rectangular microstrip patch designed to operate at 2.4 GHz. A transmission line biasing circuit is also used so that VCSEL bias or PD current can flow across the patch further reducing component count [8]. A microstrip carrier is used to mount the photonic device and is soldered on to the reverse side of the antenna creating a uniform ground plane for both antenna and microstrip carrier.

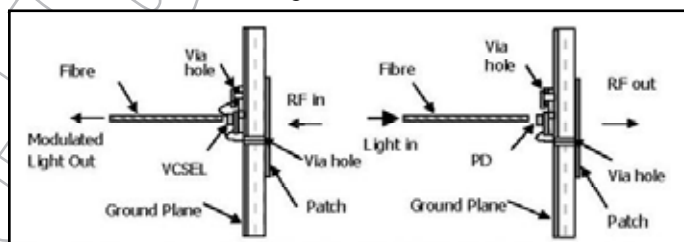

Fig. 5: Configuration of PhAIAs: (a) VCSEL and (b) Photodiode [13]

Fig. 5 (a) and (b) show side views of the VCSEL and PD integrated antenna devices. It can be seen that current can flow across the antenna, through the bond wire onto the microstrip carrier, through the VCSEL and back to the common ground through a second bond wire and ground via.

#### A. Input Impedance of VCSELs and PDs

The key feature of a PhAIA-based system is the ability to achieve relatively wideband conjugate matching between the photonic device and the antenna with no, or at least very simple, matching networks. This results in maximum power transfer and can result in significant improvement in link gain over a narrow bandwidth. This makes the approach ideally suited to WiFi-signal-distribution applications, and multiband or wideband antennas can be used to distribute signals simultaneously in other bands. Since RoF systems are often narrowband, very efficient conjugate matching can be achieved through the use of lossless matching networks or, in the case of PhAIAs, by positioning the contact point of the photonic device to the antenna at the appropriate position to achieve matching [12].

The VCSEL input impedance is close to  $(37 + j2) \Omega$  for frequencies close to 2.4 GHz and at typical bias currents [14]. This implies that quite straightforward conjugate matching can be achieved,

since the reactive part of the impedance is very low. The resistance and reactance for the PD, is much more capacitive in nature with an impedance at 2.4 GHz of  $(10 - j100) \Omega$ . This is a zero biased value, which becomes less capacitive as reverse bias is applied. Conjugate matching is more difficult and requires additional series or parallel matching elements to be added [14].

### B. Basic Link Gain

The low frequency gain can be described by the following relationship [12].

$$G = S_i^2 \eta_{if}^2 \eta_{id}^2 T_f^2 S_d^2 \frac{R_D}{R_L}$$

Where  $S_i$  is the slope efficiency of the laser,  $S_d$  is the responsivity of the PD,  $\eta_{if}$  and  $\eta_{id}$  are the coupling efficiencies from the laser and PD to MMF, respectively,  $R_D$  and  $R_L$  are the impedance of the PD and VCSEL respectively, and  $T_f$  is the loss in the fiber.

Since the slope efficiencies are measured directly into the MMF, they can be grouped together with the coupling efficiency terms, and the loss of the short length of MMF can be ignored. Taking a VCSEL slope efficiency of 0.4 W/A, and PD responsivity of 0.6 A/W,  $R_D \approx 10 \Omega$  and  $R_L \approx 37 \Omega$ , a link gain is then obtained of -18.07 dB.

The bandwidth increases for increasing forward bias; however, this can be at the expense of noise and linearity performance. Therefore a trade-off has to be made between these various factors.

### C. Linearity of the Basic Link

In any communication system, linearity is a critical factor. The linearity of VCSEL-based radio-over-fiber (ROF) links is assessed based on 1-dB compression point ( $G_{1dB}$ ) and spurious free dynamic range (SFDR) [12]. All active RF devices are ultimately non linear in operation. When driven with a large enough RF signal, gain compression will occur; this is characterized by the 1-dB gain compression point [12].

Table 1: SFDR Requirements [12]

Applications	SFDR Requirement (dB, Hz <sup>2/3</sup> )
GSM (900 MHz, indoor)	100
PCS (1900 MHz)	72-83
HiperLAN (5 GHz)	94
IEEE 802.11a (5 GHz)	94
IEEE 802.11b (2.4 GHz)	94

The gain of the link is derived from the RF power at the fundamental frequency. However, because of the non linearity of the VCSEL and PD, the RF output power will contain not only the signal at the fundamental frequency but also at harmonic frequencies [12]. SFDR is a measure of the performance of a non linear system when operating with more than one input signal. SFDR can be mathematically defined as the following:

$$SFDR_{dB} = \frac{2}{3} (P_{31} - N_1)$$

Where  $P_{31}$  is the third order intercept point in (dBm), and  $N_1$  is the noise floor of the link in (dBm/Hz).

The main sources of noise within links such as this are thermal noise, shot noise, and Relative Intensity Noise (RIN). This link is dominated by RIN and the noise power at the output can be

calculated as follows:

$$P_n = \frac{\langle I_D \rangle^2}{2} R_L 10^{RIN/10}$$

Where  $I_D$  is the average PD current, and  $R_L$  is the PD load resistance, assumed to be 50  $\Omega$ . Assuming a responsivity for the PD of 0.6 A/W, an average optical power of 1 mW, and a RIN value of -130 dB/Hz, which is a typical value for these types of lasers, we obtain a noise power of -150.5 dBm/Hz. There is an increase in SFDR with increasing VCSEL current. The SFDR requirement for various wireless application is shown in Table 1. The SFDR can be improved from 70 to 100 dB.Hz<sup>2/3</sup> by increasing the VCSEL bias current from 3 to 9 mA. The SFDR obtained in this system satisfies the requirements for a number of applications, such as microcellular personal communication systems and WLAN. Noise floor is an important factor in improving the SFDR.

### D. Noise Figure of the Link

The noise performance of the link can be expressed in terms of noise fig. [12]. The noise figure of an analog link is a measure of the degradation of the Signal to Noise Ratio (SNR) between input and the output of the link. The noise figure, NF, of the link is defined as:

$$NF = 10 \log \left( \frac{S_i/N_i}{S_o/N_o} \right) = 10 \log \left( \frac{N_o}{g_i n_i} \right)$$

Where  $S_i$  is input signal,  $S_o$  is the output signal,  $N_i$  is input noise power,  $N_o$  is the output noise power and  $g_i$  is the link gain.

The input noise is the thermal noise from a matched resistive load and can be written as:

$$N_i = kT\Delta f$$

Where  $k$  is Boltzmann's constant which has a value of  $1.38 \times 10^{-23}$  J/K,  $T$  is the measured temperature and  $\Delta f$  is the measurement bandwidth.

The output noise of the link ( $N_o$ ) has three sources which are thermal noise,  $N_{ot}$ , shot noise,  $N_{os}$ , and relative intensity noise,  $N_{or}$ . In a 1 Hz bandwidth they can be defined as follows:

$$N_{ot} = g_i kT + N_a$$

$$N_{os} = 2qI_d R_o$$

$$N_{or} = \frac{I_d^2}{2} R_o 10^{RIN/10}$$

Where  $q$  is electron charge which has a value of  $1.602 \times 10^{-19}$  C,  $I_D$  is the average photodiode current, RIN is the laser relative intensity noise in dB,  $R_o$  is the output load resistance and  $N_a$  is the additional noise representing the effects of all the internal link noise sources at the link output.

The noise figure can be reduced dramatically by decreasing the VCSEL bias current. However, there exists a trade off with the linearity of the link which is worst at low VCSEL current.

In reality long fibers are used and this has two competing effects. Firstly there is decreased link gain which leads to increased noise figure. However, the extra fiber loss reduces the PD current and thus reduces both the shot noise and RIN noise.

## V. Full Duplex Radio-over-Fiber System

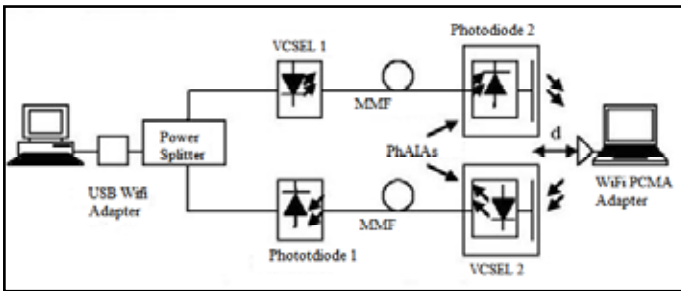

Fig. 6: System Configuration [12]

A full duplex RoF system uses vertical cavity surface emitting lasers (VCSELs) and photodiode (PD) integrated with microstrip patch antennas. The basic system configuration is shown in figure 6. Here, a universal serial bus (USB) wireless adapter operating in 802.11b mode is used as an access point; this is connected via a coax splitter to a VCSEL transmitter and a PD receiver. The fibers are connected to a VCSEL antenna and a PD-antenna, and a wireless-enabled laptop is then placed a distance from the PhAIAs. This configuration forms the basis for a range extension system, which would tap RF power from an existing access point and feed this into an in-building fiber network and re-transmit the access point signal from the low cost PhAIA-based remote node. It is particularly important for maintaining the low cost operation that no RF amplification is being used. It may even be possible to power the remote node using power-over-fiber techniques, and the low operating current of the return VCSEL will ideally be suited for this application [12]. The IEEE 802.11 WLAN standard could be used to provide communication between a number of subscriber terminals as a client/server wireless configuration in infrastructure mode, or as an ad-hoc network using peer-to-peer mode, or a fairly complicated distributed network. The IEEE 802.11 standard defines two basic modes of system architecture to provide connectivity to wireless terminals [15].

## A. Bi-Directional Link Using PhAIAs in Adhoc Mode

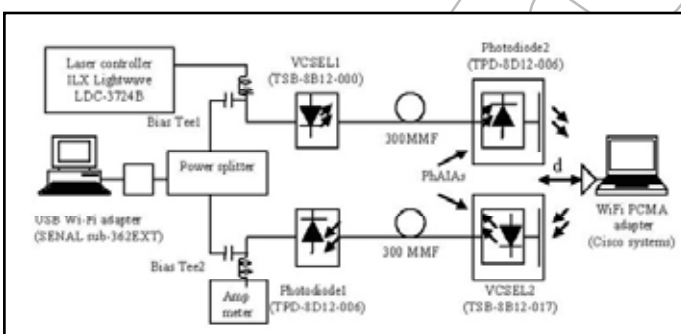

Fig. 7: Diagram of bi-directional Links on Ad-Hoc Mode [14]

All the components discussed in the preceding sections are brought together in a fully bi-directional twin fiber based system [7]. The layout for the system is shown in fig. 7. A USB wireless adaptor is used to mimic a hotspot, the external antenna is removed so that the signal could be fed directly into a non antenna VCSEL and PD transceiver. This system then takes this WiFi signal and can retransmit it using a remote PhAIA based transceiver after some length of MMF.

There are three main developments with respect to the system configuration. Firstly, this is a fully low cost module using two VCSELs and two photodiodes. Secondly, no RF amplification

is used in the module (an important point for low cost, low DC power system). Thirdly, only one antenna-antenna link is used, this has the effect of increasing the input power to the link and this is the main reason why amplification can be removed and RF range is increased.

## B. Bi-Directional Link using PhAIAs in Infrastructure Mode

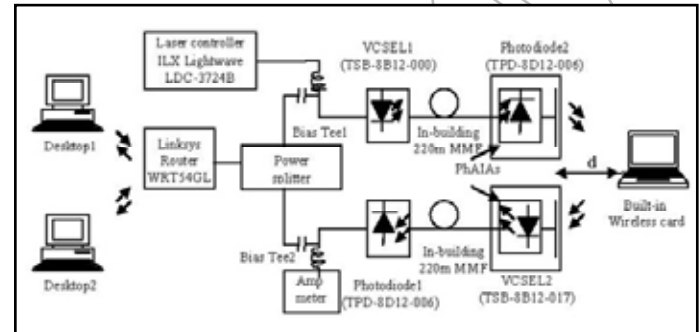

Fig. 8: Diagram of bi-directional Links on Infrastructure Mode [14]

In the previous section adhoc or peer to peer mode was explained where only two computers communicate directly [14]. In general, the computers will talk to each other via a router or access point in infrastructure mode as shown in figure 8. There are number of issues associated with this particularly the long delay that the MMF will introduce into the system.

## VI. Conclusion

Radio over fiber is an essential technology for the integration of broadband wireless and optical access networks and enables a flexible access network infrastructure capable of offering broadband wireless connectivity to a variety of services and applications. RoF technologies can provide a range of benefits including the realization of a future proof architecture with the ability to support multiple radio services and standards. It provides a flexible, reliable and cost effective approach for remotely interfacing with multiple remotely located antennas by reducing system complexity with a centralized architecture that incorporates a simplified BS located closer to the customer.

Using PhAIAs, photonic devices are integrated directly with planar devices. Since the photonic device and antenna are highly integrated a very efficient impedance matching is achieved which leads to improved link gain. The system is inherently low cost and does not use any RF amplification, though the additions of low noise amplifiers would be a straightforward extension. This would, however, require substantial DC power at the remote node, and will severely impact the commercial viability of the approach.

## References

- [1] Y. Yashchyshyn, A. Urzedowska, A. Chizh, S. Malyshev, and J. Modelski, "Integrated Photonic Antenna Unit for Dual WLAN Band Applications", Proceedings on the 5th European Conference on Antennas and Propagation (EUCAP), April 2011, pp. 220-222.
- [2] K. David, Technologies for the Wireless Future Volume 3, John Wiley & Sons, Inc., UK, pp. 9.
- [3] N. Neumann, R. Trieb, W. Benedix, and D. Plettemeier, "Active Integrated Photonic Antenna Array", 2012 IEEE-APS Topical Conference on Antennas and Propagation in

- Wireless Communication (APWC), September 2012, pp. 648-651.
- [4] N. Neumann, R. Trieb, and D. Plettmeier, "Remotely Operated Active Integrated Photonic Antenna Array", 2012 Loughborough Antennas and Propagation Conference, November 2012, pp. 1-4.
- [5] C. Chuang, C. Liu, T. Ismail, X. Wang, Y. Hao, C. Parini, P. Huggard, A. Krysa, J. Roberts, and A. Seeds, "IEEE 802.11a Data Over Fiber Transmission Using Electromagnetic Bandgap Photonic Antenna With Integrated Asymmetric Fabry-Perot Modulator/ Detector", *Journal of Lightwave Technology*, Vol. 26, No. 15, August 2008, pp. 2671-2678.
- [6] T. Prakoso, R. Ngah, T. Rahman, and Z. Ghassemlooy, "A High Gain Active Photonic Antenna for High Speed Backhaul Link: A System Analysis", *IEEE 17th International Conference on Telecommunication*, April 2010, pp.455-461.
- [7] N.F.Nanyan, R. Nagh, T. Prakoso, Y. Rahayu and T.A. Rahman, "An Active Downlink Photonic Antenna", *International Conference on Photonics*, July 2010, pp. 1-5.
- [8] J. M. Senior, *Optical Fiber Communications: Principles and Practice*, Pearson Education Limited, 2009, pp. 294 & 473.
- [9] G. Keiser, *Optical Fiber Communications*, Tata McGraw-Hill, 2008, pp. 134 & 242.
- [10] C. Balanis, *Antenna Theory Analysis and Design*, New York, John Wiley & Sons, 2005, pp. 727.
- [11] G. Kumar and K. P. Ray, *Broadband Microstrip Antennas*, Artech House, 2003, pp. 1.
- [12] V. Sittakul, and M. Cryan, "A 2.4-GHz Wireless-Over-Fibre System Using Photonic Active Integrated Antennas (PhAIAs) and Lossless Matching Circuits", *IEEE Journal of Lightwave Technology*, Vol. 27, No. 14, July 2009, pp. 2724-2731.
- [13] V. Sittakul, and M. Cryan, "A Fully Bidirectional 2.4-GHz Wireless- Over-Fibre System Using Photonic Active Integrated Antennas (PhAIAs)", *IEEE Journal of Lightwave Technology*, Vol. 25, No. 11, November 2007, pp. 3358-3365.
- [14] V. Sittakul, and M. Cryan, "A 2.4-GHz Wireless-Over-Fibre System Using Photonic Active Integrated Antennas (PhAIAs) in Adhoc and Infrastructure Modes", *Proceedings of Asia-Pacific Microwave Conference*, December 2007, pp. 1-4.
- [15] T. L. Singal, *Wireless Communications*, Tata McGraw-Hill Education, 2010, pp. 563-569.



Jovita Serrao received her B.E. degree in Electronics and Telecommunication from St. Francis Institute of Technology, Mumbai, India in 2011. She is currently pursuing M.E. from Sardar Patel Institute of Technology, Mumbai, India. She is a lecturer at St. Francis Institute of Technology, Mumbai University. Her research interests are antenna and wave propagation, optical

fiber communication and microwave.



Awab Fakhri received his B.E. degree in Electronics and Telecommunication from Xavier Institute of Engineering, Mumbai, India in 2011. He is currently pursuing M.E. from Vidyalandkar Institute of Technology, Mumbai, India. He is a lecturer at Anjuman-I-Islamic Kalsekar Technical College, Mumbai University. His research interests are optical fiber communication, signal processing, digital communication and

electrical networks.