

(3 Hours)

[Total Marks : 80

- N.B. :** (1) Question No. 1 is compulsory.
 (2) Solve any **three** questions from the remaining **five**.
 (3) **Figures** to the right indicate **full marks**.
 (3) **Assume** suitable data if required and mention the same in the answersheet.

80

1. Solve any five :—

20

5

- (a) Draw the high frequency hybrid -pi equivalent circuit of a BJT and define the various components in the model.
 (b) Define differential and common mode gain, and differential and common mode input impedance of differential amplifiers.
 (c) Draw the circuit diagram and derive the relationship between the output current and reference current for Wilson current source.
 (d) Compare power BJTs and power MOSFETS. Determine the required power rating of a power BJT for the circuit given below.

5

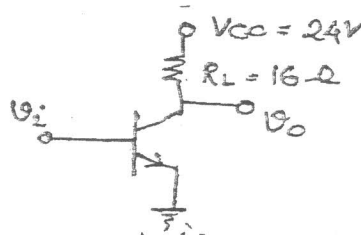

- (e) List the characteristics of an ideal op-amp and compare with the practical ones.
 (f) With the help of a neat circuit diagram explain the working of transistorized series regulator.

2. (a) Determine the corner frequency and maximum gain of a bipolar common-emitter circuit with an input coupling capacitor. 10

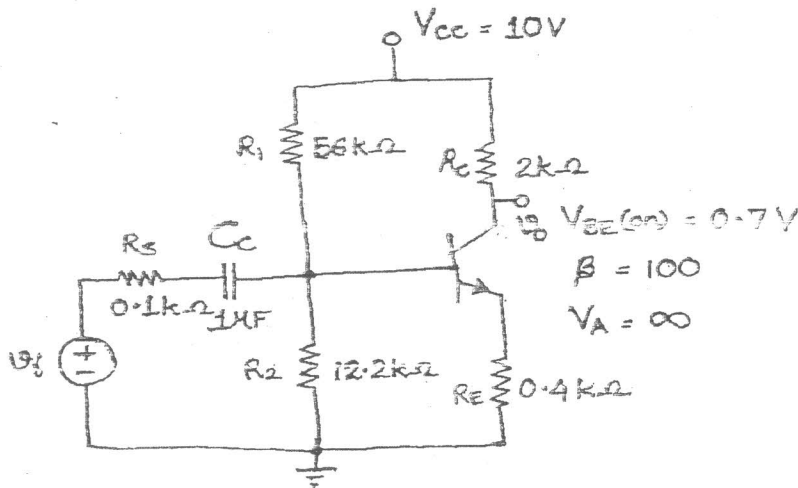

- (b) Determine the unity-gain bandwidth of N-channel MOSFET with parameters $K_n = 0.25 \text{ mA/V}^2$, $V_{TN} = 1\text{V}$, $\lambda = 0$, $C_{gd} = 0.04\text{pF}$, $C_{gs} = 0.2 \text{ pF}$, $V_{GS} = 3\text{V}$. If a $10 \text{ k}\Omega$ load is connected to the output between drain and source determine the Miller capacitance and cut off frequency.
3. (a) Draw the small signal equivalent circuit of the bipolar differential amplifier. Determine its output voltage in the general form for one sided output $V_o = A_d V_d + A_{cm} V_{cm}$, and hence the expressions for differential mode gain and common mode gain.
- (b) For the MOSFET differential amplifier, the transistor parameters are $K_{n1} = K_{n2} = 0.1 \text{ mA/V}^2$, $K_{n3} = K_{n4} = 0.3 \text{ mA/V}^2$, $V_{TN} = 1\text{V}$ for all transistors, $\lambda = 0$ for M_1, M_2 and M_3 and $\lambda = 0.01 \text{ V}^{-1}$ for M_4 . Determine the bias current I_Q , output resistance of current source, differential-mode voltage gain, common-mode voltage gain and CMRR for the differential amplifier.

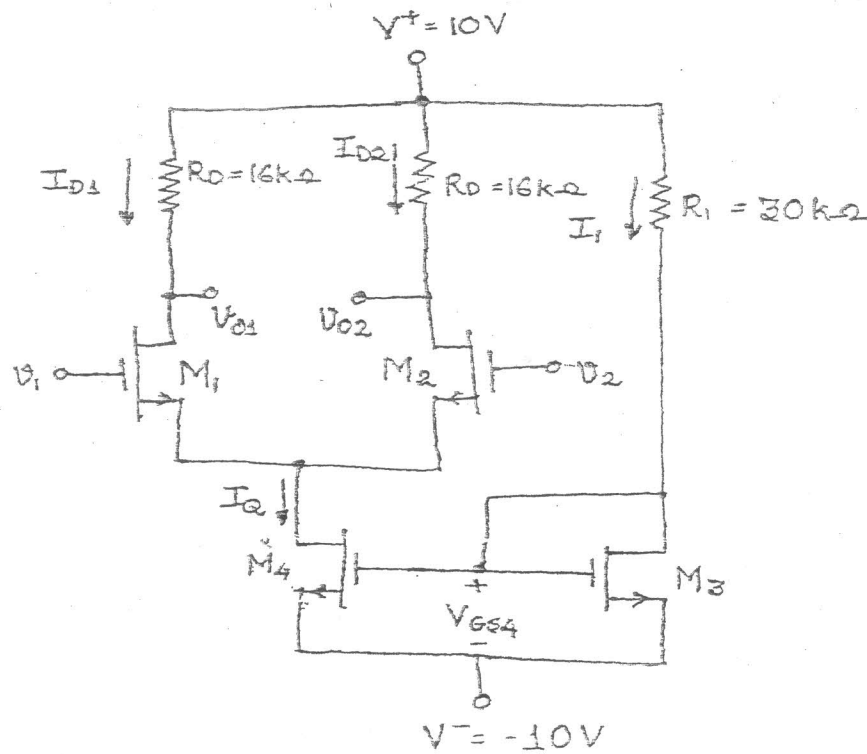

4. (a) Determine I_{REF} and I_o for the two transistor current source. The circuit parameters are $V^+ = 10V$, $V^- = 0V$, $R_1 = 15 k\Omega$ and transistor parameters are $V_{BE(on)} = 0.7V$, $\beta = 75$, and $V_A = \infty$. 4

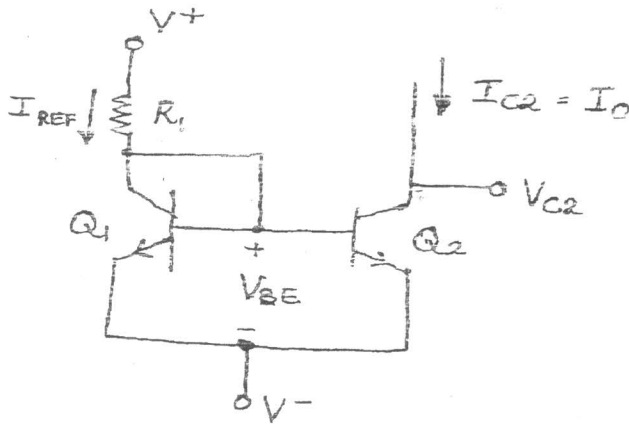

80

5

5

- (b) Draw a neat diagram of a Widlar current source. Derive the relationship between the reference and bias currents. 8

- (c) Draw the circuit diagram and small signal equivalent circuit for a Darlington pair configuration. Derive the expression for its input resistance and overall current gain. 8

5. (a) Define slew rate. With the help of waveforms shown how slew rate affects the output response of an operational amplifier to a rectangular input voltage pulse. If the bias current of an op-amp is $19 \mu A$ and its internal frequency compensation capacitor has a value of $30 pF$ determine its slew rate. 8

- (b) Draw the circuit diagram for a summing amplifier and determine the expression of output voltage v_o in terms of the input voltages v_1 , v_2 and v_3 , and the resistances used in the circuit. If it is desired to have $v_o = -(3v_1 + 4v_2 + 2v_3)$ find suitable values of these resistances. 8

- (c) With the help of VI characteristics of a Zener diode explain the working of a Zener shunt regulator. 4

6. (a) With the help of a neat diagram, dc and ac load lines explain the working of a transformer coupled class A amplifier. What is the effect of the transformer coupling on the power conversion efficiency of the class A amplifier. 8

- (b) List the different techniques for biasing the class-AB power amplifier and explain any one them. 8

- (c) Differentiate between two transistor and three transistor current sources. 4