

College Alumni Portal

Shaikh Asiya¹ Shaikh Tuba² Siddiqui Maryam³ Momin Alimuddin⁴ Prof. P.S Lokhande⁵
^{1,2,3,4}Student ⁵Assistant Professor

^{1,2}Department of Computer Engineering
^{1,2,3,4,5}AIKTC, University of Mumbai, Mumbai, India

Abstract— Alumni portals is providing common platform for every institute. Owing to the need to have all the Alumni (already passed out students) must be connected to the Institute, resulted in sharing their experiences, views, ideas, guidance motivations and strategies. The objective of Alumni portal application is to allow old and new students of the college to have communication. This allows students to know about each other and their current activities. This portal highlights the feature of communication, which will enable the current students to have interaction with the alumni of the college for getting various updates on current industry trends, Internship opportunity, sponsored projects and various referrals opening in the corporate world. This portal will serve the cause of integrating all the stakeholders of Institute such as , Alumni, College students , Faculties to avail the guidance and knowledge sharing on various domains. In this project we proposed the Dynamic Architectural design of the Alumni portal, which enable the two way communication between all stakeholders.

Key words: Portal, Alumni Portal, Stakeholders, Entrepreneur, Dynamic Architecture, Interest Matching Engine, Peer To Peer, Special Interest Group

I. INTRODUCTION

What is alumni portal - An alumni portal is a platform where the alumni, college and the college/institute students can communicate with each other for their benefit. The students can pass on their queries or their views or experiences on to portal regarding certain internship opportunities and events.

A. What is the use of this portal -

- 1) Connecting and Networking with different alumni
- 2) Follow current threads and events
- 3) View internship opportunities provided by the alumni
- 4) Referral recruitment drives

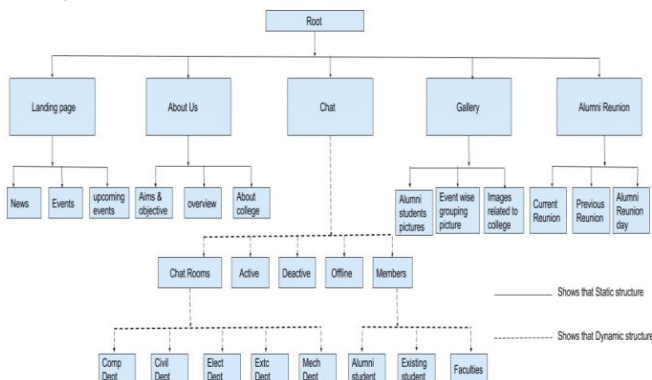

Fig. 1: Structure of Portal

II. LITERATURE REVIEW

For the Alumni Portal We have observed Five current alumni Portals.

A. Harvard Alumni Portal:

Front page of this portal shows the features like login tab so that the alumnus can login easily, ways to connect for connecting the junior and the pass out students, make gift for various occasions like birthdays or anything else. With that Harvard provides Features News for surrounding information's, Lecture details which describes the schedule, events and the Notice are displayed on home page itself with the present event. Also gives the Donor Initiative Chance for the scenario when the alumni student he/she feels that they can help the college in terms of donation so that will be possible with this. Apart from all this we have observe the unique feature that is it provides the clubbed video on the home page and this thing makes the whole portal very much attractive[4].

B. IIT Kanpur:

IIT has Gallery with many images, Lectures details with specific day and time; contacts which show whom all are connected with this portal, woman alumni convention as separate for the woman only on the Home page. And Features are Gallery present on the home page; visit for guide allocations is given so that the junior student can get the solution or the advice for their difficulties. And Notice with highlighted form is shown for better visualization. Also gives the Donor Initiative Chance. And IIT KANPUR shows information events about present on every page where the current events are highlighted also there is a separate women alumni convention and that is the unique feature[5].

C. Alumni Princeton University:

This portal has different things in their front page like Calendar for the current and the incoming occasions. This portal is provides the features that is same as the IIT KANPUR like Gallery present on the home page, visit for guide allocations is given so that the junior student can get the solution or the advice for their difficulties. But the different thing is that this portal provides the scholar ship in terms of donor initiative for the collage requirement purpose. Providing the unique feature like the alumnus are categorized on the basis of regions communities of networks so that the students who belongs to the same area will get listed together[6].

D. ITMB Alumni Association:

In the home page this portal shows the search tab for searching the alumni student whether he/she is connected in the portal or not provides the similar features like all portals Harvard Alumni Portal, IIT Kanpur, Alumni Princeton University. The notice is present in the highlighted form not only for the better visualization but also for making the portal active. Also provided Donor initiative for college. And the unique feature which makes ITMB Alumni

Association more unique is the search tab which is shown on every page[7].

E. UCLA Alumni Portal:

The UCLA ALUMNI PORTAL's home page layout is very much attractive, shows the similar features like all the portal which we have discussed yet. But unfortunately there is no notice section because of that the portal not shows any

surrounding information .And also the donor initiative is present in the form of scholarship[8].

F. Disadvantage:

Over all we found Disadvantage that the Junior applicant cannot communicate with the Alumni that makes the portal complicated. And also the conservation is hidden or not displayed from the other student who all is connected with that particular portal.

Sr. No	Parameters	Harvard	IIT Kanpur	Princeton	ITMB	UCLA
1.	Landing Page	<ul style="list-style-type: none"> - Connect - Volunteer - Programs & Events - Stories 	<ul style="list-style-type: none"> - About IITKA - Gallery - Lectures - Women Convention 	<ul style="list-style-type: none"> - Calendar - Alumni - Events - About US - Contact Us 	<ul style="list-style-type: none"> - Reunions - Initiatives - Events - News - Resources 	<ul style="list-style-type: none"> - Upcoming Events - Alumni Connections - Get Involved
2	Features	Programs & Events: <ul style="list-style-type: none"> - *All events - *searching based on events - *Online learning - *Travel 	About IIT KA: <ul style="list-style-type: none"> - *Aims - Objectives - *Overview - History 	Calendar: <ul style="list-style-type: none"> - Searching based on event - *Day wise - Week wise, - Month wise - Upcoming events 	Reunion: <ul style="list-style-type: none"> - *Register for reunion - *Gallery- - *Event wise - Grouping - Feature 	Upcoming Events: <ul style="list-style-type: none"> - *Events
		Stories: <ul style="list-style-type: none"> - *campus - *Community - *Student experience - *Teaching & learning - *Science & engineering 	Gallery: <ul style="list-style-type: none"> - *Event Twist - Grouping - Feature - Lectures: - *Alumni - Lecture series - *Departmental series 	Alumni services : <ul style="list-style-type: none"> - *Alumni - Classes - *Graduate - Alumni - *Regional association - *Future - *Alumni 	Initiatives : <ul style="list-style-type: none"> - *Fund - Raising - *Creating - Clubs - Events : - *Achievements - *Past events - *Alumni article - Resources : - *Articles 	Alumni Connections: <ul style="list-style-type: none"> - *Alumni Network - *Finding bruins in near by area - *Find bruins on social network - *Newsletter - Get Involved : - *Volunteers - *Give - *Events
3.	Notices	<ul style="list-style-type: none"> - Yes, Notices are displayed on landing page. 	<ul style="list-style-type: none"> - Yes, Notices are displayed on landing page. 	<ul style="list-style-type: none"> - Yes 	<ul style="list-style-type: none"> - Yes 	<ul style="list-style-type: none"> - Yes
4.	Donor Initiative	<ul style="list-style-type: none"> - Yes 	<ul style="list-style-type: none"> - Yes 	<ul style="list-style-type: none"> - No 	<ul style="list-style-type: none"> - Yes 	<ul style="list-style-type: none"> - Donation in scholarship form.
5.	Unique Features	<ul style="list-style-type: none"> - Dubbed video's of various events on home page 	<ul style="list-style-type: none"> - Members Area, current events - Current event is highlighted - A separate Women Alumni Convention 	<ul style="list-style-type: none"> - Upcoming alumni event with a logo or a picture/banner - Online lectures - Volunteers profiles 	<ul style="list-style-type: none"> - Search Tab - Campus tour 	<ul style="list-style-type: none"> - Attractive layout - Connecting alumni students via social n/w or sites

				- Alumni categorized on the basis of communities networks.		
6.	Disadvantage	Junior applicants are not able to communicate with alumni student. Also the conversation between the alumni and other person is not displayed.				

Table 1: Literature Review Summary

G. Short Falls in Existing System/Portal:

- Majority of the alumni portals do not provide connection between alumni's.
- No chat rooms specific to topic/ interest / domain.
- No direct registration

H. How to Overcome:

- Proposed method to overcome on shortfalls includes following features.
- Provided Special interest group (SIG) chat rooms.
- Personal in private chatting.
- Access of contact details on request.
- Auto registration of all students.
- Passed out students are promoted as alumni automatically upon completion of their course.

B. Project Scope:

- This alumni portal would provide common platform to interact students, alumni and college altogether [1].
- Portal provides dynamic feature such as active user status, chat rooms, personal chatting & messaging
- Virtual alumni meetings
- Job posting
- Internships
- Industry sponsored projects
- Entrepreneurial guidance.
- Online expert lecture videos

III. PROBLEM STATEMENT

We are formulating the best alumni web portal which will facilitate effective communication platform through online chatting, profile viewing and personal messaging within three stakeholders of the institute which are - College , College students, Alumni.

A. Motivation:

- Although our college website is quite attractive but it lacks with the feature of communication with the alumnus.
- This creates a problem for the current students in terms of guidance, internships, industrial knowledge.
- It also lacks the instant solution to the problem which are related to education and career.
- It does not provide any idea about the news and current status of jobs in different companies & industry.

IV. OBJECTIVE AND SCOPE

A. Objective:

Alumni's are:

- A valuable source for referral recruitment.
- A goodwill and PR(public relation) factor - the surviving students will view the treatment of their ex students as an indication of how they would be treated in a similar situation[3].
- Alumni are a very useful forum of critical watchers. Alumni will provide you with very valuable information about the views of the outside world about the performance of your company.

V. PROPOSED SYSTEM ARCHITECTURE

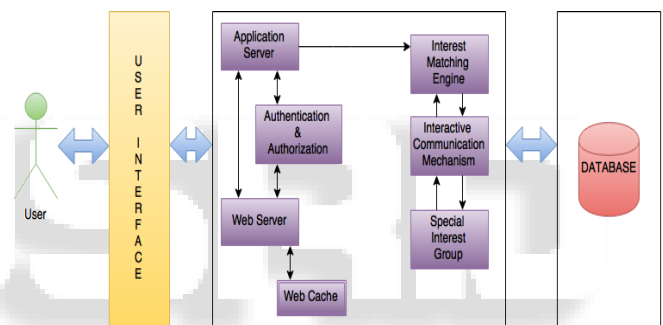

Fig 1 : Proposed System Architecture

VI. TECHNICAL DETAILS

A. Methodology:

1) Auto Registration:

People do find it very lethargic to register on any website until forced on. So this alumni portal will be providing the service of automatic registration. Once the student has been admitted into the institution, the personal details will be instantly uploaded onto the portal.

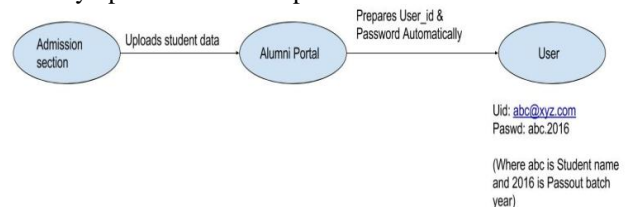

Fig 2 : Auto Registration Process

2) Interactive communication:

This portal will be providing different chat rooms for different departments such as Mechanical Dept ,Computer Department ,EXTC Department etc. and also provides different discussion rooms for certain purposes such as discussion room for different languages such as java,C,C++,C# etc

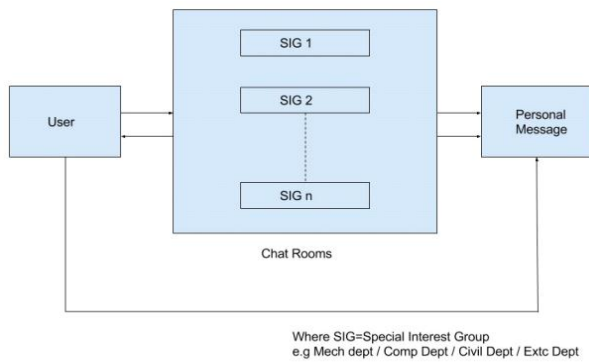

Fig 3 : Interactive Communication

3) Auto Promotion:

Auto promotion of existing students into a new role i.e. of an alumni. For e.g. Student admitted in 2012 will become alumni in June 2016.

Pseudo code for auto promotion (of regular student)
if student course is equal to 4 years and month June
then

 convert the status of user from student to alumni
else

 keep the user in current state.

Pseudo code for handling the conversion (of the failure student to an alumni)

if user has drop year

 then

 send e-mail to verify the status &&user selects "YES"

 then

 keep the user in current state

 else

 convert the status of current user to an alumni.

B. Project Requirements:

1) Software Requirements

Technology : PHP

Web Technologies: Html, JavaScript, CSS

Database : Mysql

Web Server : APACHE

2) Hardware Requirements

Processor : Intel

RAM : 1GB

VII. MARKET POTENTIAL

A. Market Potential of Project:

- We have visited many college web sites and hence we found out that college alumni portal is must.
- Our institution (AIKTC) also does not have this web portal yet. This motivated us to work on this project.
- Majority of the college websites do not have the feature of alumni web portal due to which the existing students cannot communicate with the alumnus.
- Due to lack of this service we can provide them with respective college alumni web portal through technologies such as Cloud.

B. Competitive Advantage of Project:

- 1) Communication - Direct or peer to peer communication of the students with the alumni students. Different chat rooms for different departments.

- 2) Automatic Registration - Automatic registration upon completion of course, notification through sms and email.
- 3) Birthday Reminders - Scrolling birthday notification on front page
- 4) Auto Promotion - Auto promotion of an existing student into a new role i.e. of an alumnus. For e.g. Student admitted in 2012 will become alumni in June 2016.

VIII. CONCLUSION AND FUTURE SCOPE

A. Conclusion

Alumni portal for any college website is very important. Alumni portal has been setup to increase interaction, knowledge sharing and networking among the alumni students. Alumni portal focuses on bringing together alumni students of college. The primary goal of this report is to connect the alumni students with the college and existing college students with the help of alumni web portal where they can have communication with existing students and college.

B. Future Scope

- In order to ease the work, an Android app can also be built.
- To add certain social networking features such as of LinkedIn.
- To involve companies to avail the services of this platform.

ACKNOWLEDGEMENT

We would like to thanks our guide Prof. P.S. Lokhande for giving his valuable guidance who also provided expertise that greatly assisted the research.

REFERENCES

- [1] Campus Portals: Supportive Mechanisms for University Communication, Collaboration, and Organizational Change David L. Eisler, Provost Weber State University
- [2] Security Mechanism in Alumni Portal Department of Information Technology, Xavier Institute of Engineering, Mahim (W), Mumbai, India Vikrant Pawar , Sagar Date, Suraj Iyer, Chhaya Narvekar
- [3] Cecilia A. Mercado and Gerry Paul C. Genove Towards Overcoming Limitations of Community Web Portals: a Classmates' Example DERI – Digital Enterprise Research Institute, University of Innsbruck, Austria, and National University of Ireland at Galway, Ireland Anna V. Zhdanova
- [4] "Harvard Alumni" [online]. Available: <http://www.alumni.harvard.edu>
- [5] "IIT Kanpur Alumni" [online]. Available: www.iitkalumni.org
- [6] "Alumni Princeton University" [online]. Available: www.alumni.princeton.edu
- [7] "ITMB Alumni Association" [online]. Available: www.alumni.itmb.edu
- [8] "UCLA Alumni" [Online]. Available: www.alumni.ucla.edu