

INSTRUCTIONS: 1. Question number 1 is **COMPULSORY**. 2. Attempt any **THREE** from the remaining. 3. Each full question carries **EQUAL** marks. 4) **ASSUME** any suitable data, if needed.

1. A) A Reinforced Concrete Slab (2400 mm X 2400 mm) & 225 mm. thick is lifted by 4 cables attached to the corners (fig. 1). The cables are attached to a hook at a point 1500 mm above the top of the slab. Each cable has an effective cross-sectional area $A = 9 \text{ mm}^2$. Determine the tensile stress in the cables due to the weight of the concrete slab. Weight density of concrete = 24 kN/m^3 . (04 M)

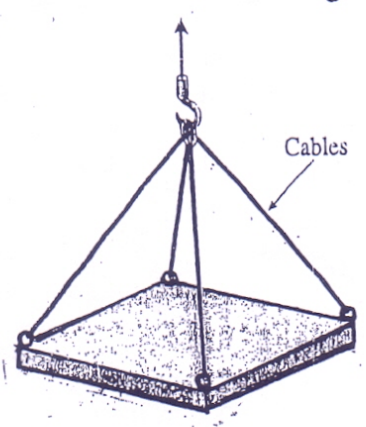

FIG. 1

- B) State the assumptions made in the Theory of Pure Torsion. (04 M)
- C) A cylindrical shell is 4m long & has 1.3 m internal diameter. It is subjected to an internal fluid pressure of 3 MPa. If the shell thickness is 10 mm, find the hoop stress & longitudinal stress. (04 M)
- D) What are the assumptions made in the Theory of Pure Bending? (04 M)
- E) Locate the Core (Kernel) of the solid rectangular section having a width of 300 mm & a depth of 400 mm. (04 M)

2. A) The footing supports the load transmitted by two columns (fig. 2). Draw the Shear Force Diagram & Bending Moment Diagram for the footing if the reaction of soil pressure on the footing is assumed to be uniform. Neglect the self weight of the footing. (08 M)

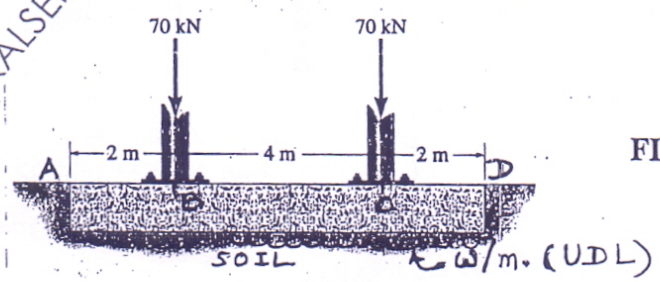
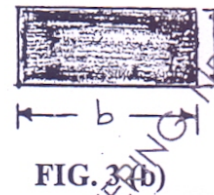
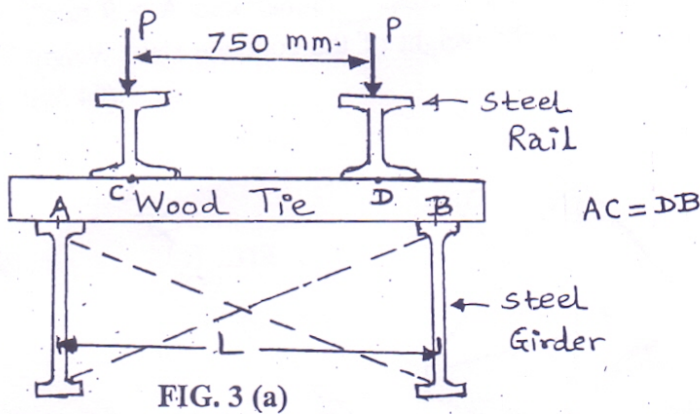

FIG. 2

MUPD16025 ANJUMAN-I-ISLAM'S KALSEKAR TECHNICAL CAMPUS COLLEGE OF ENGINEERING, NEW PANVEL 24-05-2016 13:38:06

B) The cross-section of a narrow gage railway bridge is shown in fig. 3 (a). The bridge is constructed with longitudinal steel girders that support the wood cross ties. The girders are restrained against lateral buckling by diagonal bracing, as indicated by the dashed lines. The spacing of the girders is $L = 1250$ mm & the spacing of the rails is 750 mm. The load transmitted by each rail to a single tie is $P = 6675$ N. The C/S of a tie (fig. 3 b), is having width $b = 125$ mm & depth d . Find the minimum value of d based on an allowable bending stress of 7751.25 N/m² in the wood tie. A & B are simple supports. Disregard the weight of the tie itself. (08 M)



C) Write a brief note on Flitched Beams. (04 M)

3. A) A T-section beam has top flange of (120 mm X 20 mm) & web of (20 mm X 100 mm). The overall depth is 120 mm. It is subjected to a Shear Force of 60 kN. Draw Shear Stress Distribution Diagram. (08 M)

B) If the solid shaft AB to which the valve handle is attached, is made of red brass, determine the diameter of the shaft, so that the angle of twist does not exceed 0.5° & the shear stress of shaft material does not exceed 40 MPa when $F = 25$ N. Take Modulus of Rigidity $G = 37$ GPa. Refer fig. 4. (08 M)

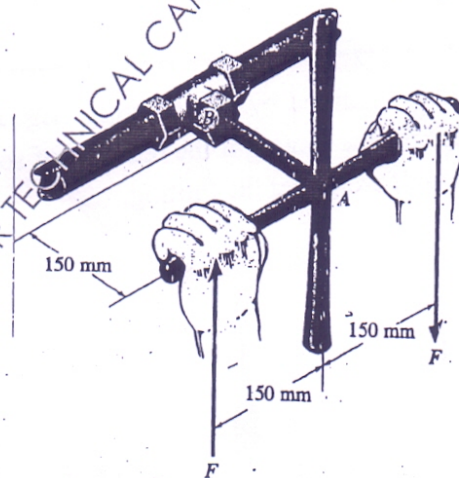
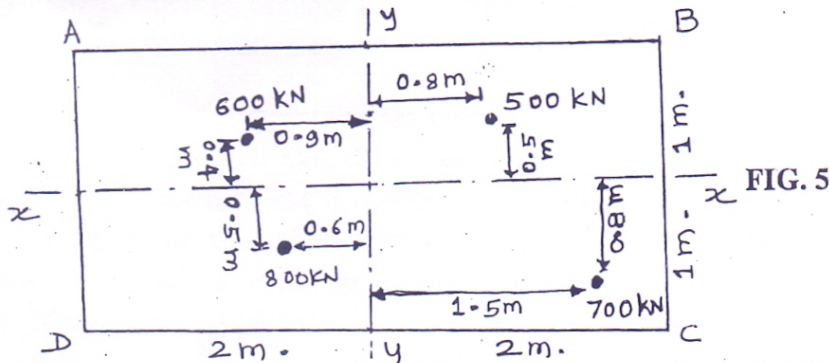

FIG. 4

C) For a rectangular beam section, show that the maximum shear stress is 1.5 times the average shear stress. (04 M)

4. A) An RCC footing is having dimensions as shown in fig. 5. It carries 4 loads as indicated. Calculate the resultant stresses at the corners A, B, C & D. (08 M)



- B) Fig. 6 shows an element in a stressed body. Determine normal, tangential & resultant stresses on a plane Q-Q inclined as shown. Either use analytical method or graphical method. (08 M)

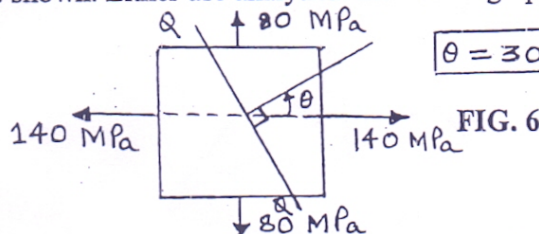

- C) The length of an aluminium rod 10 mm diameter & 400 mm long increases to 400.15 mm when subjected to a tensile force of 2 kN. Find the stress in the bar & Young's modulus. (04 M)

5. A) A copper rod, 12 mm diameter & 400 mm long, fits in to an aluminium tube of external diameter 20 mm & thickness 4 mm., of equal length. If the assembly is held together by a rigid plate at the end & is stress-free at 20°C, find the stresses in the two materials when it is heated to 60°C. $E_{\text{copper}} = 120 \text{ GPa}$ & $\alpha_{\text{copper}} = 18 \times 10^{-6} / ^\circ\text{C}$; $E_{\text{al}} = 70 \text{ GPa}$ & $\alpha_{\text{al}} = 23 \times 10^{-6} / ^\circ\text{C}$. (08 M)

- B) A vertically hung bar is 2 m long & has a diameter of 25 mm. A weight of 600 N is dropped from a height (h) on a collar attached to the lower end of the bar. Find the height of drop, if the stress in the bar is not to exceed 100 MPa. Also find the maximum weight that can be dropped from this height without causing any permanent deformation. The elastic limit is 220 MPa & $E = 200 \text{ GN/m}^2$. (08 M)

- C) A simply supported beam of span 5 m carries a clockwise couple of 10 kNm at the centre of the span. Draw Shear Force Diagram & Bending Moment Diagram. (04 M)

6. A) Derive bending equation $(M/I) = (\sigma/y) = (E/R)$, with the usual notations. (08 M)

- B) A hollow cylindrical column, with both ends hinged, is 6 m long & has an outer diameter of 120 mm & an inner diameter of 80 mm. Compare the crippling loads obtained by Euler's & Rankine's approach. $E = 80,000 \text{ MPa}$ & crushing strength = 550 MPa. The Rankine constant = (1/1600). What is the length of the column if both crippling loads are equal? (08 M)

- C) A block of 250 mm height & (45 mm X 40 mm) cross-section is to support a centric compressive load P. The material to be used is bronze for which $E = 95 \text{ GPa}$. Determine the largest load that can be applied, knowing that the normal stress must not exceed 124 MPa & that the decrease in height of the block should be at most 0.12% of its original length. (04 M)