

Literature Review for Design of Elliptical Bicycle

¹Prof. Saad Shaikh, ²Yasser Arafat Shaikhnag, ³MohammedJawwaad Surangiwala, ⁴Saniya Aslam Khan, ⁵FalakNaaz Shaikh

Abstract:- Customization design is a trend for developing a bicycle in recent years. Thus, the comfort of riding a bicycle is an important factor that should be paid much attention to while developing a bicycle. From the viewpoint of ergonomics, the concept of “fitting object to the human body” is designed into the bicycle frame in this study. Firstly the important feature points like riding posture, frame design, wheel size, materials required, method of manufacture and types of failures are discussed. Further this study proposes a detailed methodology which is helpful for the designer to develop an elliptical bicycle in an efficient and economical manner.

Keywords:- Bicycle frame, suitable material, fatigue failures, FEA analysis, riding postures, ride height, frame joints, CFD.

I. INTRODUCTION

A bicycle, often called a bike or cycle, is a human-powered, pedal-driven, single-track vehicle, having two wheels attached to a frame, one behind the other. The bicycle has undergone continual adaptation and improvement since its inception. These innovations have continued with the advent of modern materials and computer-aided design, allowing for a proliferation of specialized bicycle types.

Bicycles can be categorized in many different ways: by function, by number of riders, by general construction, by gearing or by means of propulsion. The more common types include utility bicycles, mountain bicycles, racing bicycles, touring bicycles, hybrid bicycles, cruiser bicycles, and BMX bikes. Less common are tandems, low riders, tall bikes, fixed gear, folding models, amphibious bicycles and recumbents. Unicycles, tricycles and quadracycles are not strictly bicycles, as they have respectively one, three and four wheels, but are often referred to informally as "bikes".

The bicycle is extraordinarily efficient in both biological and mechanical terms. The bicycle is the most efficient human-powered means of transportation in terms of energy a person must expend to travel a given distance. From a mechanical viewpoint, up to 99% of the energy delivered by the rider into the pedals is transmitted to the wheels, although the use of gearing mechanisms may reduce this by 10–15%. In terms of the ratio of cargo weight a bicycle can carry to total weight, it is also an efficient means of cargo transportation.

A recent trend and a new type of bicycle has its advantageous impact on human life called as the elliptical bicycle. Elliptical bikes combine the motion of an indoor elliptical trainer with the outdoor mobility of a traditional bicycle. The ElliptiGO is the world's first elliptical bicycle.

By modifying the elliptical trainer motion and combining it with the functionality of a bicycle, the ElliptiGO line of bikes delivers a high-performance workout experience that closely mimics running outdoors while eliminating the impact. It provides the most comfortable, fun and efficient way to get out and stay active.

ElliptiGO co-founder and former Ironman triathlete Bryan Pate was inspired to create the world's first elliptical bicycle after injuries plagued him to the point where he could no longer run for fitness. Although he was an experienced cyclist, Pate chose instead to use the elliptical trainer to stay fit because it was more comfortable than sitting on a bike.

Unsatisfied with the experience of working out in a gym, however, Pate had a vision of creating a product that would allow him to have both the outdoor “running experience” and the low-impact workout of the elliptical machine. In 2005, Bryan partnered with ElliptiGO co-founder Brent Teal, a mechanical engineer and ultra-marathoner, to design and develop the world's first elliptical bicycle.

II. LITERATURE REVIEW

A Bi-cycle frame should have low weight, high lateral stiffness and moderate vertical stiffness. Because of chain load, frame lateral deformation during pedalling is bigger when the rider pushes on right pedal (a pro rider may apply a force up to two times his weight). Most of the bicycles built today utilize heat treated steel or aluminium or titanium alloy tubing to minimize their weight. The tubes are then welded together to create the desired fork or frame geometry. [1]

In recent years, as manufacturers of racing bicycles and bicycle components have turned to wind tunnel testing to optimize component design³, the athletes themselves are now able to purchase time in wind tunnels to refine and perfect their riding positions. Comprehensive reviews by Burke⁴ and Lukes cite many efforts which validate the conventional wisdom that the main contributors to overall drag are the rider, the frame including fork and aerobars, and the wheels. Greenwell et.al.⁶ have concluded that the drag contribution from the wheels is on the order of 10% to 15% of the total drag, and that with improvements in wheel design, an overall reduction in drag on the order of 2% to 3% is possible. [2]

Since their invention in 1817, bicycles have proven to be a healthy and environmentally friendly mode of transportation for both enthusiasts and commuters alike. Although the bicycle has remained ubiquitous over time, the world has changed dramatically. Today, US roadways are dominated by automobiles, aggressive, modes of human transport. Unfortunately, bikers are considered second-class citizens as they attempt to share roadways with motorists. In fact, this has been the situation for most of the lifetime of the bicycle. [3]

A schematic of bicycle frame size obtained from the riding experiment is shown in Fig. 1 Generally, the three key feature points: handlebars, the saddle and the central crank, were used as the kernel to mark the frame size. A represents the vertical distance from the saddle to the ground; B the vertical distance from the crank center to the ground; C the vertical distance from the handlebars to the ground; D the horizontal distance from the handlebars to the saddle; and, E the horizontal distance from the crank center to the saddle. By this marking method, different frame sizes for different human dimensions could be clearly illustrated. [4]

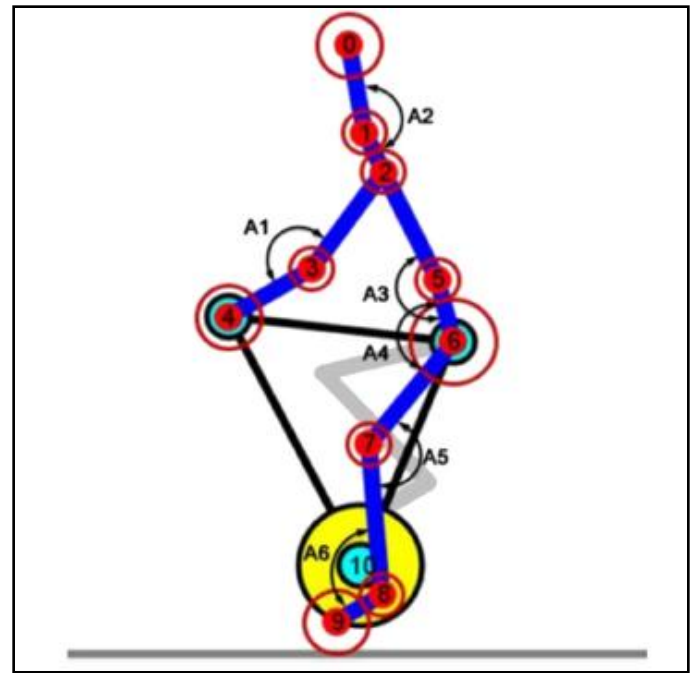

Fig. 1:- Positions of feature points and their feature angles formed when riding. [4]

Spoked bicycle wheels are efficient, highly evolved, structural systems. A useful analogy for a bicycle wheel supporting vertical loads is that of a circular beam on a prestressed elastic foundation, fixed at the center and loaded radially at the circumference. To apply this analogy, the system of interlacing spokes can be modeled as a disk of uniform stiffness per length of circumference. Spokes of varying lengths may be laced into wheels of fixed dimensions, by modifying the interlacing geometry of the spokes. [5]

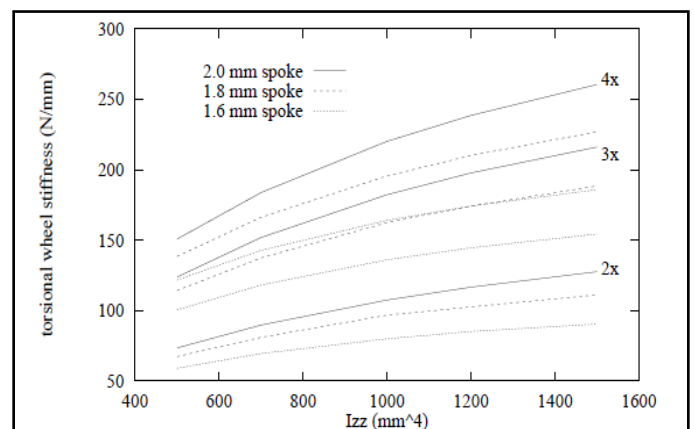

Fig. 2:- Tangential stiffness for various bicycle wheel designs. [5]

It is possible to build a bicycle frame with very little equipment. I have done it myself. It took me a lot longer than it would if I had a few more items of quality equipment, and it was awkward and took lots of concentration. Deciding on the right amount of equipment is up to the individual frame builder. It will depend on how he/she wishes to make frames, the space available to house the equipment and the finances at their disposal. As can be seen in my case studies, frame builders can be successful using several different “philosophies” with regard to equipment. Take Richard Sachs for example: he is one of the most well-known and successful frame builders in the world, yet he doesn’t have a milling machine or a lathe. In fact, his workshop is noticeably devoid of equipment apart from a frame jig, a couple of benches, a vice and some hand tools. [6]

What are the best materials to use in bicycle frames—steel? aluminum? carbon fiber? magnesium? titanium? The answer lies in the physical properties of these materials—their characteristics and how they behave under certain conditions. The designer chooses the material that best suits the intended use of the bike (road or off road), and the expected cost (titanium and carbon fiber are especially expensive). Listed below are some of the properties bike designers look at when they build a bicycle.

Density- Density is how much a material weighs for a given volume.

Stiffness- The measurement for stiffness is called the modulus of elasticity; it is the degree to which a material that undergoes stress can deform, and then recover and return to its original shape after the stress ceases

Elongation- Elongation is a measure of how far a material will stretch before it breaks. It is very sensitive to the type of alloy used and how the metal is processed.

Tensile Strength- Tensile strength is a measure of the greatest longitudinal stress a substance can bear without tearing apart; it is expressed as a ratio of maximum load to crosssectional area.

Fatigue Strength- Fatigue strength is a measure of the stress at which a material fails after a number of cycles. Steel and titanium alloys have a specific fatigue strength below which a load (force) may be applied an infinite number of times without causing the metal to bend or break.

Toughness- Toughness is the ability of a metal to absorb energy and deform before fracturing (breaking). A tough metal is more ductile (pliable) and deforms rather than breaks. [7]

Fatigue is a prominent failure mechanism for mountain bike frames, and can lead to serious accidents, costly recalls, and poor product image for bicycle frame manufacturers. The team collaborated with a local bike company, in the process of developing a new 6061-T6 aluminum mountain bike, to investigate the fatigue behavior of the new frame and optimize the material/heat treatment and frame design. [8]

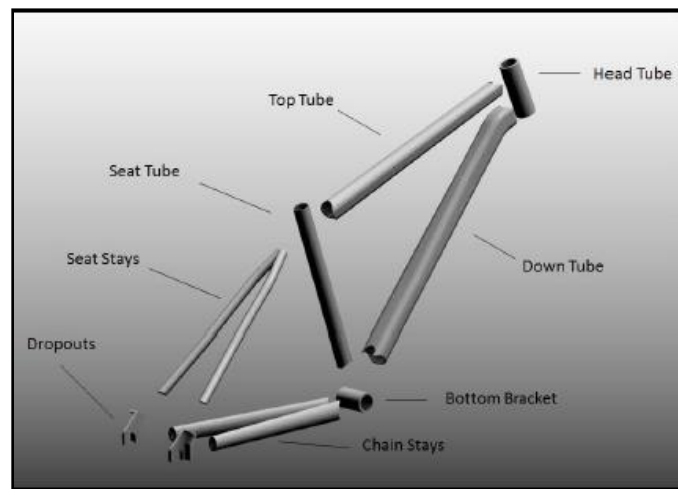

Fig. 3:- Tubing diagram of the donated bicycle frames. [8]

As far back as 1986, Peterson and Londry (1986) used FEA to fine-tune the design of the Trek 2000 aluminium frame using two other existing designs (one steel, one aluminium) as performance benchmarks for mass, strength and stiffness characteristics. Their model used beam elements to represent the tubular frame structure (excluding forks) with restraints at the rear axle and head tube, and loads applied in a range of load cases at the seat tube, head tube, brake bridge, and bottom bracket (BB). While this study did not include an analysis of varied geometry, the analysis of varied load cases provided a rich insight into various generic performance characteristics, for example that energy losses in the vertical direction could be increased with little negative effect on hill climbing performance (i.e. an out of saddle load case) and that the down tube was always the greatest strain energy absorber, storing between 38-49% of the total (followed by the seat tube, storing between 19-25%). [9]

Developments have recently been made in analysis of bicycle self stability. Applicability of benchmarked linearized dynamics equations to a variation of modern bicycle designs is

investigated. Results gained through experimentation on an instrumented bicycle with variable geometry are compared to predicted results. Precise three dimensional modeling is used to calculate bicycle mass properties, for use in dynamics equations. Strong correlations between experimental and predicted results are found over large variations in bicycle geometry. Bicycles have been the subject of much research throughout their development. This thesis studies self stability of bicycles, which until recently had not been completely captured and verified mathematically. [10]

Most mechanics textbooks or treaties on bicycles either ignore the matter of their stability or treat it fairly trivial. The bicycle is assumed to be balanced by the action of its rider who, if he feels the vehicle falling, steers into the direction of the fall and so traverses a curved trajectory of such a radius as to generate enough centrifugal force to correct the fall. The next level of sophistication in current bicycle stability theory invokes the gyroscopic action of the front wheel. If this bike tilts, the front wheel processes about the steering axis and steers it in a curve that as, before, counteracts the tilt. [11]

An experimental analysis of the frame design for a hybrid bicycle was presented. The analysis was conducted to obtain an understanding of the dynamics load distribution which may be encountered during competitive riding. Experimental measurements were also necessary for a verification of numerical analysis. Dynamic strains resulting from typical riding events indicated that the design scaling from static to dynamic events required a scaling factor of at least 20. In addition, the load history resulting from dynamic activities provided the appropriate information necessary for a preliminary fatigue design analysis. [12]

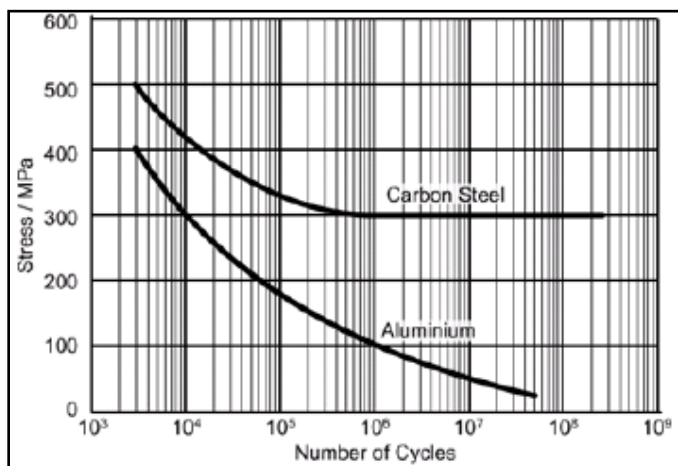

Fig. 4:- Fatigue limit of aluminum vs. steel [12]

In this work CFD was used to explore the complex and unsteady nature of air flow around several commercially available front bicycle wheel configurations. Extending our previous work, this study examined more realistic front wheel geometry, adding the front fork, top tube, head tube, down tube, caliper and brake pads to the modeling domain: Three wheels, namely the Zipp 404, Zipp1080 and HED H3 TriSpoke were considered. In addition, two commercially available front fork designs, the Reynolds Carbon fork and the Blackwell Bandit slotted fork, were also studied. [13]

To obtain a sense of the relative performance merits for the design configurations studied here, the overall power requirements were calculated for each combination of front wheel and fork; wheel only configurations were not included here. In general, it was observed for all cases that the power requirement needed to increase the speed from 20mph to 30mph went up by a factor slightly greater than three. This result is consistent with the convention that the increase in power goes up with the cube of the increase in speed. [14]

Several critical issues such as the wheel rim depth and cross-sectional profile, wheel diameter (650c or 700c), and development of an integrated front fork/frame/caliper assembly, optimized to work with a specific wheel, still remain open. We believe that CFD is now in a position to fully explore wind tunnel discoveries, and advance the understanding of the critical design changes which ultimately lead to the performance improvements sought after by competitive and amateur cyclists and triathletes. [15]

In this paper, we present an approach that solves the problem by offloading the low-level cognitive requirements from a biker to her bicycle. To support this approach, we enhance a standard bicycle with sensing and computational capabilities to create a Cyber-Physical bicycle system. The core goal of this system is to provide accurate and timely detection of rear-approaching vehicles to alert the biker of the pending encounter, through the cross-cutting application of mobile sensing, computer vision, and audio processing techniques. [16]

The central goal of this work is to reduce the cognitive overhead of a biker to allow her to focus attention on bicycle handling and the roadway ahead. Evaluating this is a challenging problem as it requires thorough coverage of different biker skill levels, riding styles, roadway and route characteristics, environmental conditions, and user interface issues. As such, we acknowledge the importance and need for

a full user study and plan to conduct one in the future as a separate, but related piece of research. [17]

This study defined five joint angles in the measurement of riding postures. Since each feature joint angle was constantly changing during the process of measurement, this study used only the feature angles when the tests stopped at the lowest stepping point in riding as the required measured results. Meanwhile, the changing range of each testers' body angle on different bicycle types was recorded. [18]

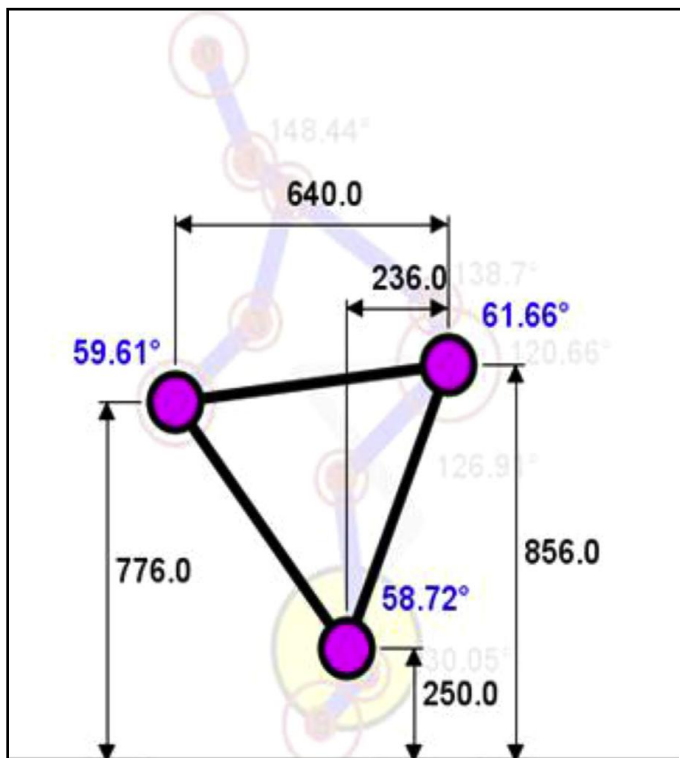

Fig. 5:- Bicycle frame size captured by detection system. [18]

The spoke pattern affects the over-all radial stiffness of the wheel more than it affects the spoke strains. From a theoretical analysis, a numerical analysis, static experimental analysis, and in-service measurements, the spoke strains appear to be insensitive to the pattern of the spoke lacing. From a numerical analysis, the spoking pattern has the greatest impact on the spoke strains when the wheel is subjected to large lateral loads, such as during cornering. In this case, wheels with longer spokes have lower strains than do wheels with shorter spokes. [19]

An investigation was conducted with the optimal material / heat treatment, and geometry design. The optimal 6013-T6 alloy was set for the frame material. The geometry was optimized with the extended weld between the top and down tube, increased radius of curvature for the down tube,

and increased down tube thickness near the bottom bracket. [20]

III. METHODOLOGY

1. Material Selection:-

The material required for developing an elliptical bicycle must be selected very carefully as the stresses and fatigue forces involved are different than the conventional bicycle. As per the material survey the best suited material is the alloy steel (SS). The mentioned material was chosen as the material for bicycle frame due to its low density and compatible yield strength. This material was chosen for designing frame and comparing its results with different materials as mild steel, EN8 etc.

Optional Material:-

1. Al-6061-magnesium and Silicon Major Alloying Element-density 2.70g/Cm³.
2. Al-7005-Zinc-density-2.78g/cm³- depending on the temper, may be slightly stronger.

2. Designing of the Model:-

The frame required to be developed for elliptical bicycle can be designed by standard designing procedures and if the load carrying capacity of the frame is known.

3. Drafting a CAD Model:-

Required CAD can be developed using 3-D modeling softwares. The cad geometry must have basic requirement for Head tube, top tube, bottom tube, chain stays, bottom bracket shell and the two triangles commonly says diamond frame. This is the model of the bicycle frame. A bicycle frame is the main component of a bicycle, onto which wheels and other components are fitted. The modern and most common frame design for an upright bicycle is based on the safety bicycle, and consists of two triangles, a main triangle and a paired rear triangle. Frames are required to be strong, stiff and light, which they do by combining different materials and shapes.

4. Meshing:-

For better quality mesh combination of first and second order tetra elements are to be used. Surface meshing using triangular elements is to be performed to achieve better control on the meshing. Further this mesh will be converted into a tetra mesh. Selective tetra elements will be converted into second

order and selective regions will be finely meshed using first order elements controlling the number of nodes formed.

5. Frame Analysis:-

Several properties of a material help decide whether it is appropriate in the construction of a bicycle frame:

1. Density (or specific gravity) is a measure of how light or heavy the material per unit volume.

2. Stiffness (or elastic modulus) can in theory affect the ride comfort and power transmission efficiency. In practice, because even a very flexible frame is much more stiff than the tires and saddle, ride comfort is in the end more a factor of saddle choice, frame geometry, tire choice, and bicycle fit. Lateral stiffness is far more difficult to achieve because of the narrow profile of a frame, and too much flexibility can affect power transmission, primarily through tire scrub on the road due to rear triangle distortion, brakes rubbing on the rims and the chain rubbing on gear mechanisms. In extreme cases gears can change themselves when the rider applies high torque out of the saddle.

6. Fabrication of the Model:-

After the analysis of the model, on analysis softwares for different loads and environmental conditions, the frame can be fabricated followed by the selection of suitable material after market survey. Fabrication techniques include welding, bending and assembly of various parts required.

7. Testing of the Fabricated Model:-

Followed by the fabrication of the actual model, it should be tested for different road and environmental conditions to identify any defects or flaws in the design or fabrication processes.

8. Troubleshooting:-

If any defects or flaws are found in the fabricated model, the defects or flaws will be corrected/rectified by taking suitable steps.

IV. CONCLUSION

The above study/ literature review proposed a method for measuring the comfortable postures of bicycle riding and applied the results to bicycle frame design. It also defines the means to effectively measure the best frame size for riders of different height ranges on different bicycle types. It could also

be used to calculate the frame sizes of common bicycle types by numeric operations. In the above literature review the size and type of wheel to be selected for a particular bicycle application is instructed. The various fatigue failures, materials required and analysis included in fabrication of a bicycle is cited in detail.

REFERENCES

- [1] Sagar Pardeshi, Pankaj Desle "Design and Development of Effective Low Weight Racing Bicycle Frame", International Journal of Innovative Research in Science, Engineering and Technology (IJIRSET). December 2014.
- [2] Matthew N. Godo, David Corson, Steve M. Legensky, "A Practical Analysis of Unsteady Flow Around a Bicycle Wheel, Fork and Partial Frame Using CFD" American Institute of Aeronautics and Astronautics.
- [3] Stephen Smaldone, Chetan Tonde, Vancheswaran K. Ananthanarayanan, Ahmed Elgammal, and Liviu Iftode, "Improving Bicycle Safety through Automated Real-Time Vehicle Detection" Department of Computer Science Rutgers University 110 Frelinghuysen Rd, Piscataway, NJ 08854, August 2010.
- [4] Shih-Wen Hsiao, Rong-Qi Chen, Wan-Lee Leng, "Applying riding-posture optimization on bicycle frame design" Department of Industrial Design, National Cheng Kung University, Tainan 70101, Taiwan, ROC, April 2015.
- [5] Henri P. Gavin, "Bicycle Wheel Spoke Patterns and Spoke Fatigue", *ASCE Journal of Engineering Mechanics*, vol 122, no. 8, (August 1996) pp. 736-742. August 1996.
- [6] Matt Wilkinson, "The Winston Churchill Memorial Trust Travelling Fellowship 2011", Bicycle Frame Building in the USA. May 2011.
- [7] Nicol, Scot, "Metallurgy for cyclists I: The basics", <http://www.63xc.com/scotn/metal.htm>, March 1999.
- [8] Forrest Dwyer, Adrian Shaw, Richard Tombarelli, "Material and Design Optimization for an Aluminum Bike Frame", Worcester Polytechnic Institute. April 2012.
- [9] Derek Covilla, Steven Begga, Eddy Eltona, Mark Milnea, Richard Morrisa, Tim Katza, "Parametric finite element analysis of bicycle frame geometries", School of Computing, Engineering and Mathematics, University of Brighton, Lewes Rd, Brighton, BN2 4GJ, UK, April 2014.
- [10] David Stevens, "The Stability and Handling Characteristics of Bicycles", The University of New South Wales, School of Mechanical and Manufacturing Engineering, June 2009.
- [11] David E.H. Jones, "The Stability of the bicycle", Feature Article. From the Archives, September 2006.
- [12] D. Arola, P.G. Reinhall, M.G. Jenkins, S.C. Iverson, "An Experimental Analysis Of A Hybrid Bicycle Frame", Journal of Experimental Techniques. May/ June 1999.
- [13] Godo, M.N, Corson, D. and Legensky, S.M., 2009, "An Aerodynamic Study of Bicycle Wheel Performance using CFD", 47th AIAA Aerospace

Sciences Annual Meeting, Orlando, FL, USA, 5-8 January, AIAA Paper No. 2009-0322.

[14] Garcia-Lopez, J., Rodriguez-Marroyo, J.A., Juneau, C.-E., Peleteiro, J., Martinez, A.C. and Villa, J.G., 2008, "Reference values and improvements of aerodynamic drag in professional cyclists", *J. Sports Sci.*, 26(3), pp. 277-286.

[15] FieldView, CFD Postprocessing Software Package, Version 12.3, Intelligent Light, Rutherford, NJ, 2009.

[16] S. B. Eisenman, E. Miluzzo, N. D. Lane, R. A. Peterson, G.-S. Ahn, and A. T. Campbell. The bikenet mobile sensing system for cyclist experience mapping. In *SenSys '07: Proceedings of the 5th international conference on Embedded networked sensor systems*, 2007.

[17] M. Enzweiler and D. Gavrilu. Monocular pedestrian detection: Survey and experiments. 31(12):2179-2195, December 2009.

[18] Bressel, E., Bliss, S., Cronin, J., 2009. A field-based approach for examining bicycle seat design effects on seat pressure and perceived stability. *Appl. Ergon.* 40, 472e476.

[19] Pippard, A.J.S., and Francis, W.E. (1931) "The stresses in a radially-spoked wire wheel under loads applied to the rim." *Philosophical Magazine*, 7(11), 233-285.

[20] ASTM Standard F2868-10, "Standard Specification for Condition 2 Bicycle Frames," ASTM International, West Conshohocken, PA, www.astm.org.

¹**Prof. Saad Shaikh** , Faculty of Mechanical Engineering, Anjuman-I-Islam's Kalsekar Technical Campus, School of Engineering and Technology, New Panvel, University of Mumbai, Maharashtra (India). Email ID:-saad.shaikh7@gmail.com

²**Yasser Arafat Shaikhnag**, B.E.Mechanical.(Student), Anjuman-I-Islam's Kalsekar Technical Campus, School of Engineering and Technology, New Panvel, University of Mumbai, Maharashtra (India). E-mail ID:-yass4uever@yahoo.com

³**MohammedJawwad Surangiwala**, B.E.Mechanical.(Student), Anjuman-I-Islam's Kalsekar Technical Campus, School of Engineering and Technology, New Panvel, University of Mumbai, Maharashtra (India). Email ID:-mohammed.jawwad@gmail.com

⁴**Saniya Aslam Khan**, B.E.Mechanical.(Student), Anjuman-I-Islam's Kalsekar Technical Campus, School of Engineering and Technology, New Panvel, University of Mumbai, Maharashtra (India). Email ID:-khanksaniya@yahoo.com

⁵**FalakNaaz Shaikh** B.E.Mechanical.(Student), Anjuman-I-Islam's Kalsekar Technical Campus, School of Engineering and Technology, New Panvel, University of Mumbai, Maharashtra (India). Email ID:-falaknazsk@gmail.com