



LIFTS & ESCALATORS

(Transportation system in buildings)

Service By KRRC (Central Library)

Faculty: Sujit Parab | Semester-6 | Building Services | Vertical Transportation | 2017-18

What is a Lift ?

The lift is a type of vertical transport equipment that efficiently moves people or goods between floors (levels, decks) of a building, vessel or other structure.

generally powered by electric motors that either drive cables, hoist, or pump hydraulic fluid to raise a cylindrical piston like a jack.



Basic terminologies..

IP@AIKTC

aiktcdspace.org

- Elevator car : That part of an elevator that includes the platform, enclosure, car frame, and door.
- Machine beam : A steel beam, positioned directly over the elevator in the machine room and is used to support elevator equipment.
- Machine room : This usually located at the top of the shaft and accommodates the winding machine, etc.
- Pit : That part of an elevator shaft that extends from the threshold level of the lowest landing door down to the floor at the very bottom of the shaft.
- Shaft : A hoistway through which one or more elevator cars may travel.
- Counterweight or balance-weight. A unit, consisting of steel weights, which counter balance the weight of the car and a portion of the load, and to which the suspension ropes are attached.

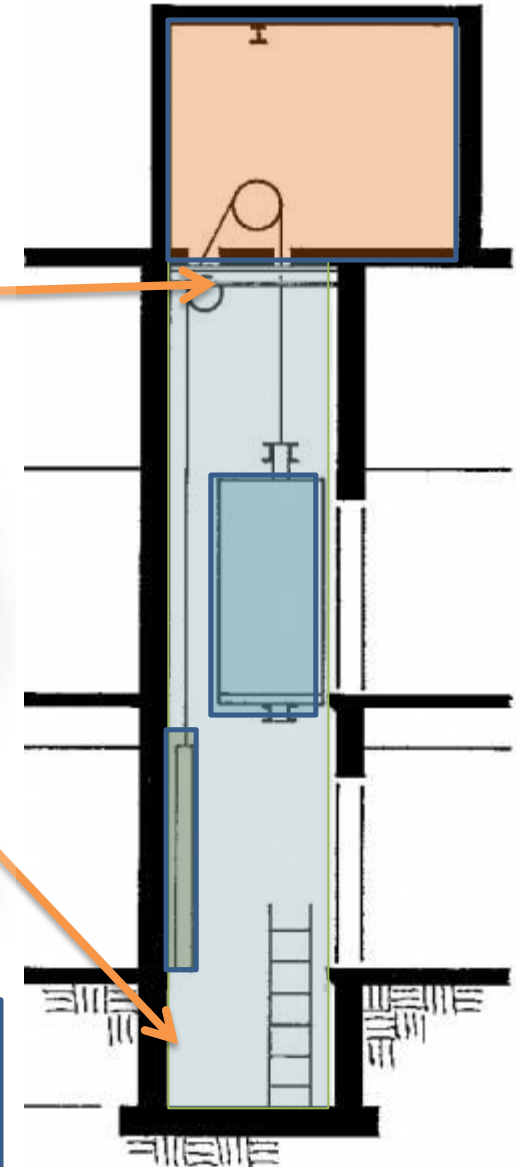

Trailing cable : Flexible cable providing electrical connection between the lift car and a fixed point or points.

•Bottom clearance : The distance, including buffer compression, the platforms could travel below the bottom landing until the full weight of the car, when loaded, rests on the buffer.

•Top clearance :The vertical distance between the top car attachment and the bottom of the diverting pulley or any steelwork supporting equipment; there must be an adequate margin between this and the car will not contact the diverting pulley or steelwork.

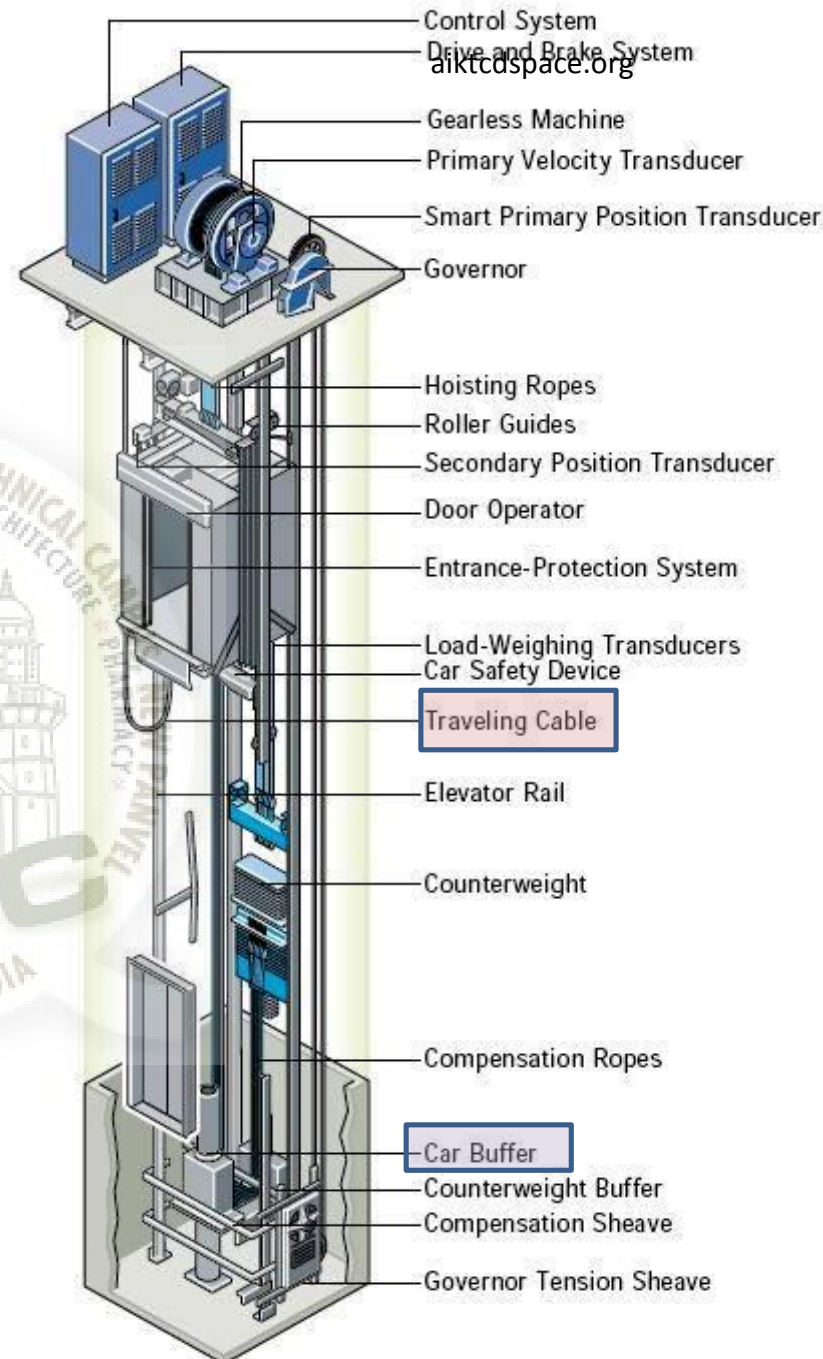

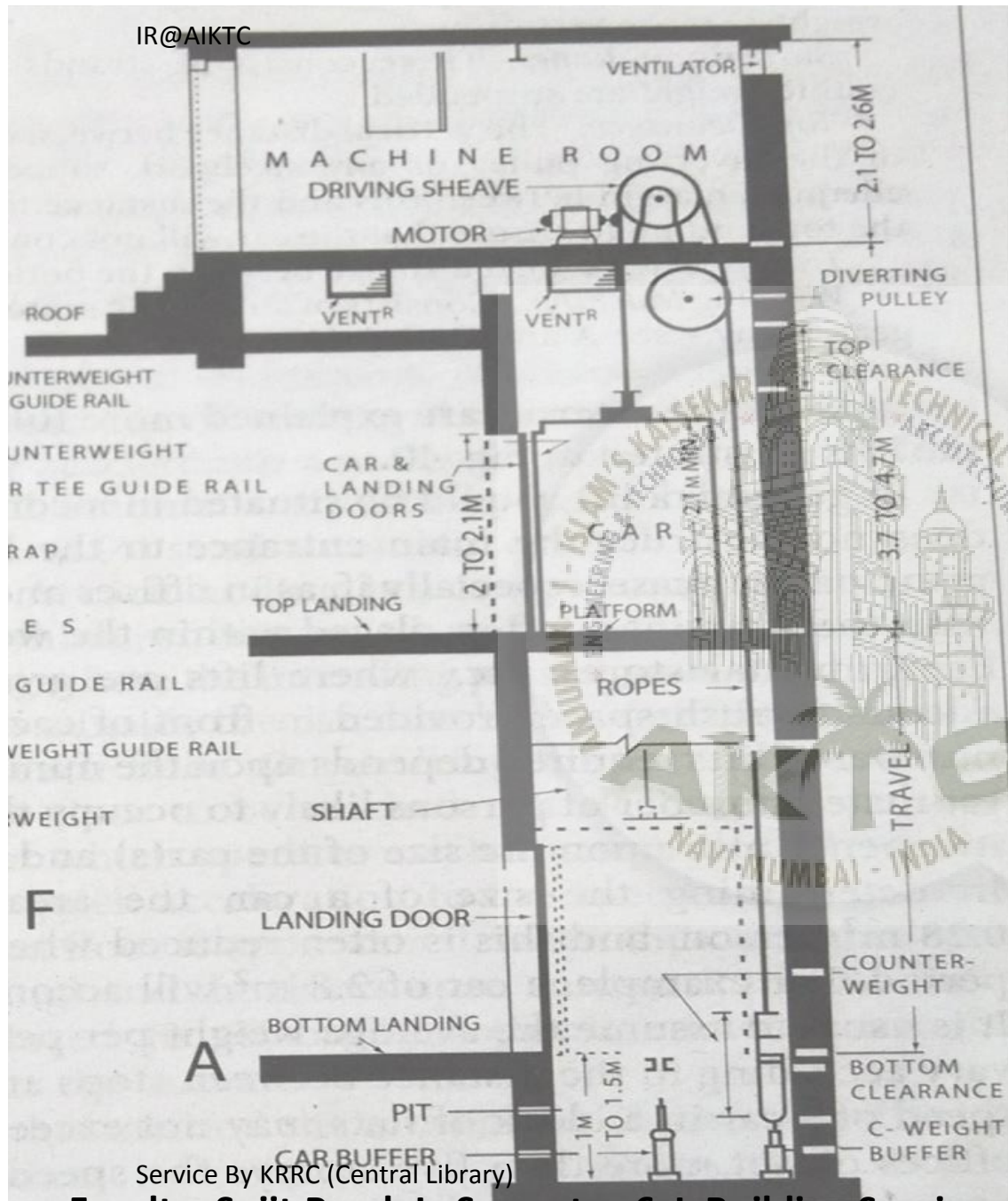

• Guide rails : These, fixed truly vertical in the shaft, are of steel and serve to guide the movement of both car and counterweight.



1. Suitable speed.....too fast will result in a nervous breakdown to the user. If too slow will cause lack of function.

- Electrical panels and power outlets.
- Ventilation fan and lighting in engine room.
- Power sockets in the lift pit for Maintenance works.

Basic Requirements

Physical Requirements

Size of lift shaft – depends on lift cargo capacity

Depth of lift shaft – depends on the speed of elevator

Area of space in lift – depends on speed of elevators.

Mechanical room size – depends on type and size of the lift equipment.

Types of Lifts

Drive system

Hydraulic

Traction
(Machine lift)

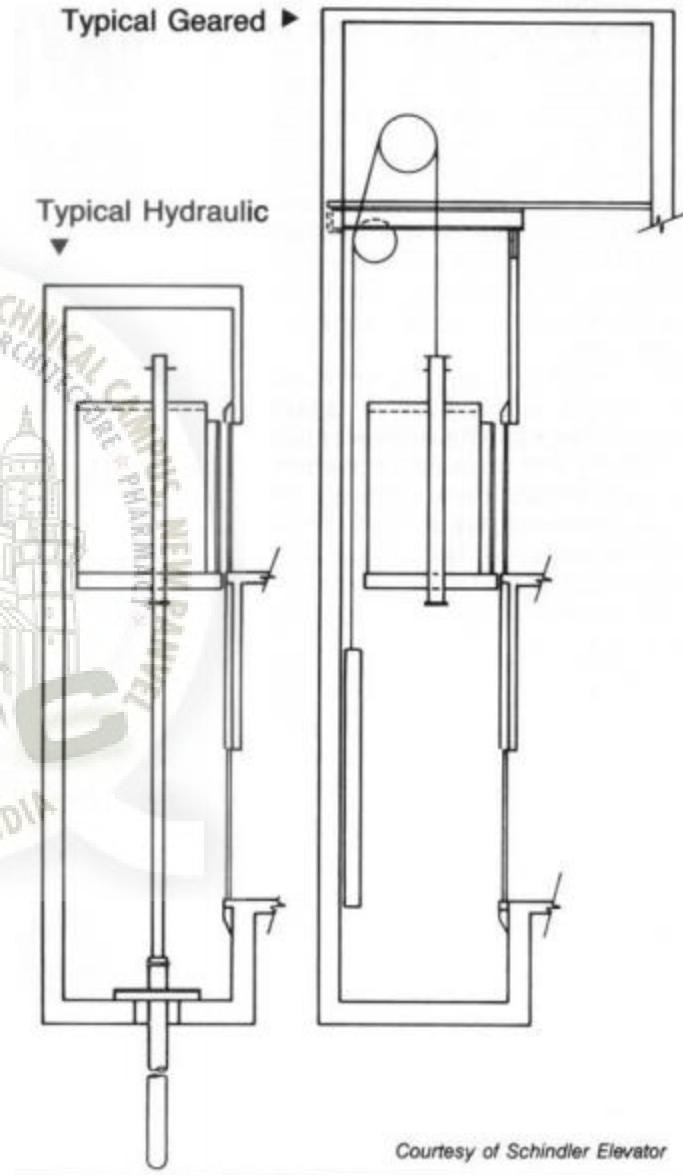

Courtesy of Schindler Elevator

1. Hydraulic lifts

IR@AIKTC

- 'Pascal's Principle state that the pressure given to liquid in closed chamber will be continued by the liquid to every direction with uniform and the same magnitude.'

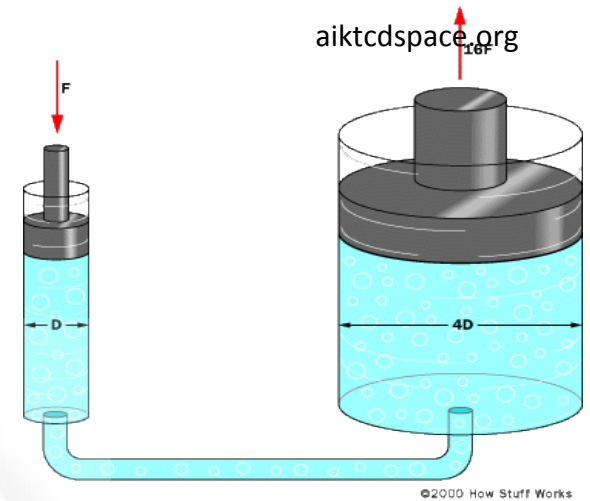

Pressure is exerted on fluid in small cylinder, usually by a compressor.

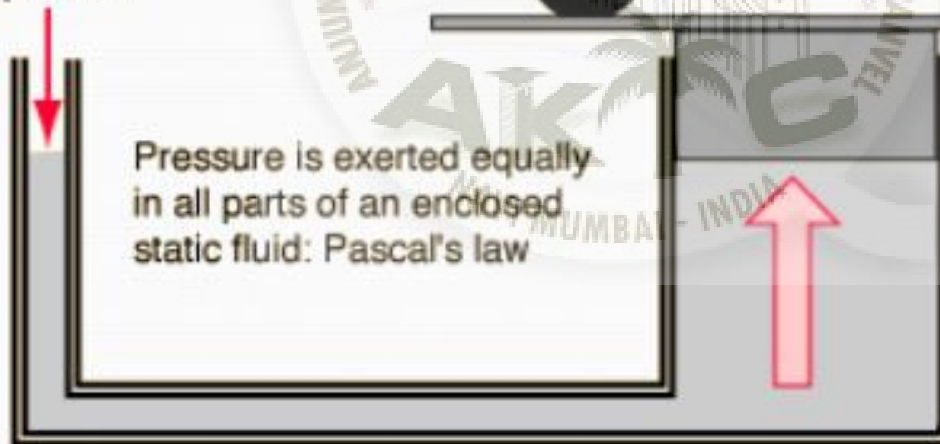

Though the pressure is the same, it is exerted over a much larger area, giving a multiplication of force that lifts the car.

The force in the small cylinder must be exerted over a much larger distance. A small force exerted over a large distance is traded for a large force over a small distance.

Service By KRRC (Central Library)

Components

Tank

- Holds the liquid used in the system
- This liquid is usually oil based because:
 - Non compressible
 - Self lubricating

Motor

- Constantly puts water into the system
- Push oil into the cylinder to lift the elevator

Valve

- Lets water out of the system.
- Keeps the pressure low when open.
- Increases pressure when closed.

Actuator

- device that transfers fluid or electrical energy into mechanical energy.
- A piston because it moves up and down.

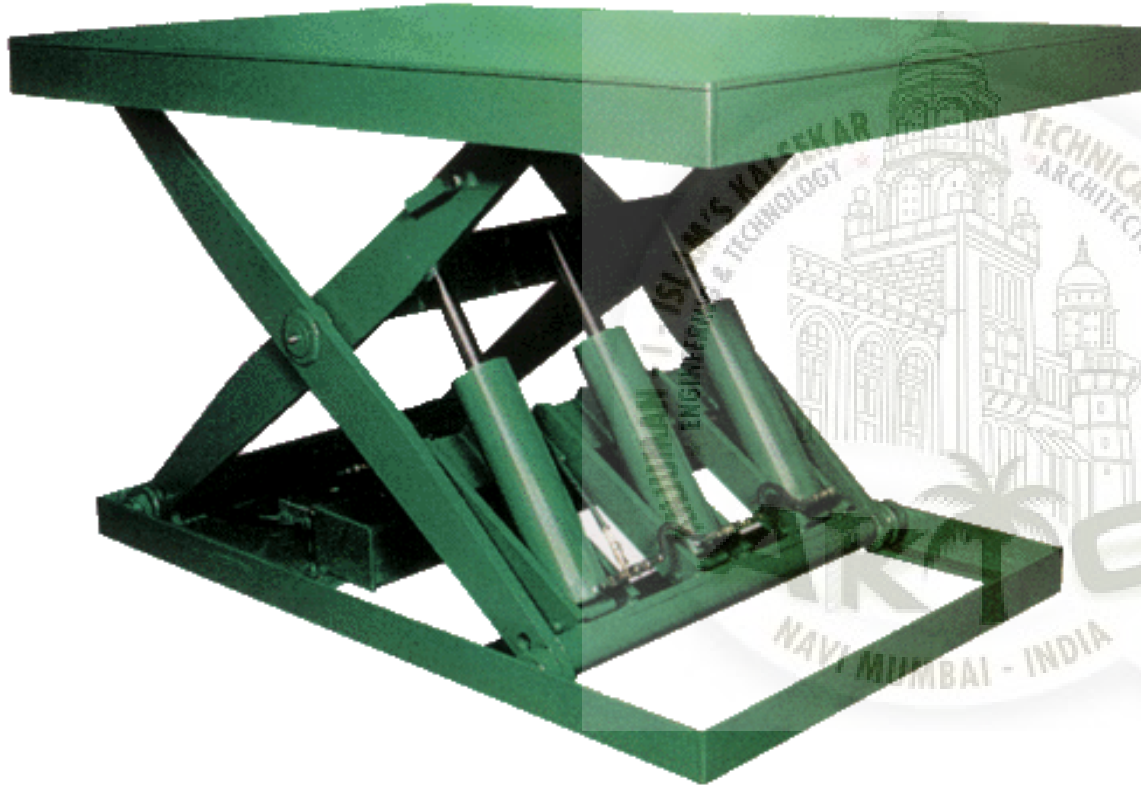

Advantages

- Lower cost of equipments & its maintenance than traction lifts (twice).

- More efficient building space utilization than tractions.

Eg., hydraulic lifts would require 9.6 sq m less floor space than tractions.

Moreover overhead machine room isn't required.

- Most effective for high load capacity requirements , that is why it is highly used for freight, automobile elevators.

- Since it imposes no vertical loads on the building structure, column sizes can be reduced significantly in the hoistway area.

Disadvantages

- Performance of hydraulic elevator becomes erratic as the oil in the system varies in temperature.

- Since it has no safety device to prevent its falling it depends wholly on the pressure .

- Inherently high heat producing device.

2. Traction Lifts (Machine lifts)

- Principle : **see – saw**
the car is raised and lowered by traction steel ropes rather than pushed from below.
- The ropes are attached to the elevator car, looped around a sheave & connected to an electric motor.
- when the motor turns one way, the sheave raises the elevator; when the motor turns the other way, the sheave lowers the elevator.
- Typically, the sheave, the motor and the control system are all housed in a machine room above the elevator shaft.
- The ropes that lift the car are also connected to a counterweight, which hangs on the other side of the sheave.

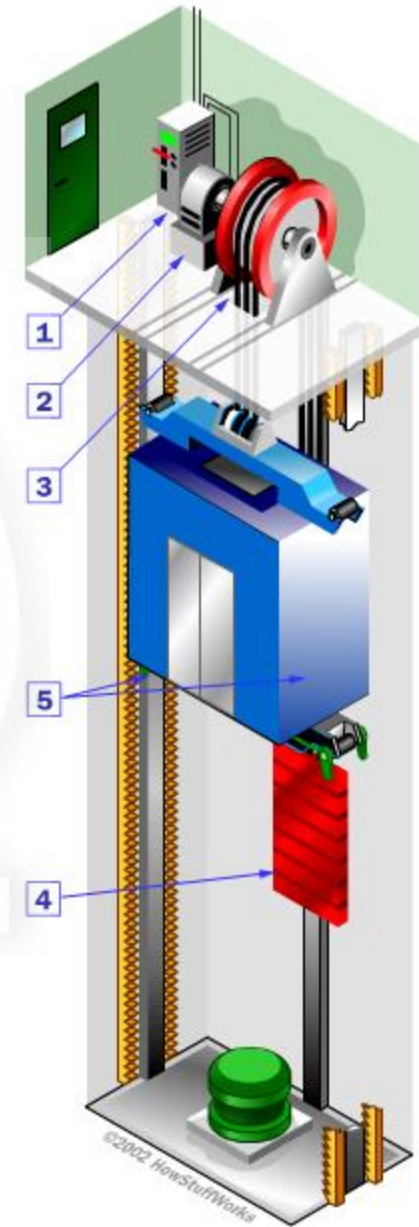

- the counterweight and the car are perfectly balanced.
- Basically, the motor only has to overcome friction -- the weight on the other side does most of the work.
- In **gearless elevators**, the motor rotates the sheaves directly. In **geared** elevators, the motor turns a gear train that rotates the sheave.
- Nowadays, some traction elevators are using flat steel belts instead of conventional steel ropes. Flat steel belts are extremely light due to its carbon fiber core and a high-friction coating, and does not require any oil or lubricant.



Service By KRRC (Central Library)



Components

Control system

Electric Motor

Sheave

Counter weight

Guiding rail

It consists mainly of 5 components,

- Sheave rotates with the help of motor.

- a pulley with a groove around the circumference.
- grips the hoist ropes, so when you rotate the sheave, the ropes move too.
- Connected to the motor

hangs on the other side of the sheave.
it weighs about the same as the car filled to 40-percent capacity.
Connected with the ropes

- Are along the sides of the elevator shaft.
- keep the car and counterweight from swaying back and forth.
- also work with the safety system to stop the car in an emergency.

Requirements for machine room :

IR@AIKTC

aiktcdspace.org

- adequately ventilated.
- shall be such that the equipments are protected as far as possible from dust and humidity.
- Temperature 5 deg C – 40 deg C
- walls, ceiling, floor should be finished in tiles or painted as a min to stop dust circulation.

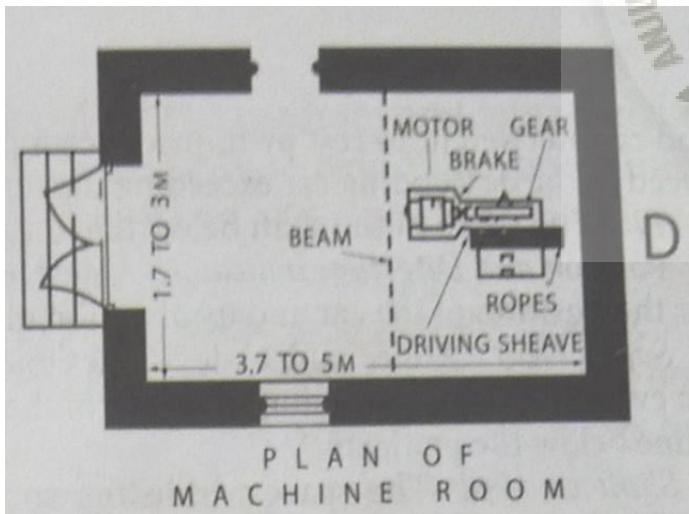
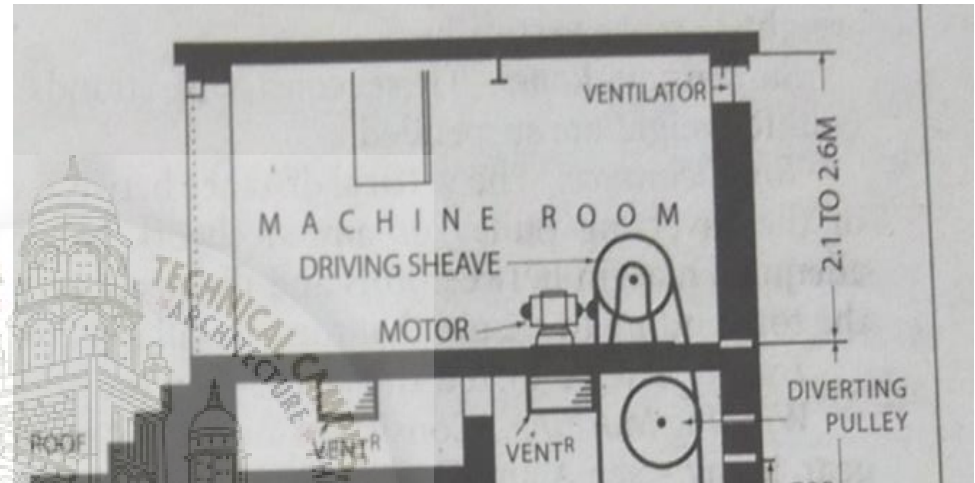

- The entrance door shall have sufficient opening to allow for in & out of machines.
- shall not be any common wall/slab between machine room and water tank.
- shall not be used as a store room or for any purpose other than housing the machinery connected with the lift installation.
- shall not act as a passage to any other room or utility.

Service By KRRC (Central Library)

IR@AIKTC



Service By KRRC (Central Library)

Difference between Traction & Hydraulic lifts

(overview)

Traction (Machine)	Hydraulic
<ul style="list-style-type: none"> •lifted by ropes, which pass over a wheel attached to an electric motor above the elevator shaft. 	<ul style="list-style-type: none"> •supported by a piston at the bottom of the elevator that pushes the elevator up as an electric motor forces oil or another hydraulic fluid into the piston.
<ul style="list-style-type: none"> •used for mid and high-rise applications. •Much higher travel speed than hydraulic. 	<ul style="list-style-type: none"> •used for low-rise applications of 2-8 stories.
<ul style="list-style-type: none"> •<i>Principle</i> : see - saw 	<ul style="list-style-type: none"> •<i>Principle</i> : Pascal's pressure principle
<ul style="list-style-type: none"> •<i>Components</i> : control system, sheave, motor, counterweight, guiding rail. 	<ul style="list-style-type: none"> •<i>Components</i> : tank, motor, valve, actuator.
<ul style="list-style-type: none"> •The machine room is located at the upper most level, i.e., on the terrace. 	<ul style="list-style-type: none"> •The machine room is located at the lowest level adjacent to the elevator shaft.

Types of Lifts

Usage

Passenger

Goods

Vehicle

Dumbwaiter

Scissor



Service By KRRC (Central Library)

TYPES OF LIFTS

- Passenger Lift : A lift designed for the transport of passengers.
- Goods Lift : A lift designed primarily for the transport of goods but which may carry a lift attendant or other person necessary for the unloading and loading of goods.
- Service Lift (Dumb-Waiter) : A lift with a car which moves in guides in a vertical direction; has net floor area of 1 m², total inside height of 1.25 m; and capacity not exceeding 250 kg; and is exclusively used for carrying materials and shall not carry any person.
- Hospital Lift : A lift normally installed in a hospital/dispensary/clinic and designed to accommodate one number bed/stretcher along its depth, with sufficient space around to carry a minimum of three attendants in addition to the lift operator.

1. Passenger lifts

• Passenger elevator is designed to move people between floors of a building. Their capacity is related to available floor space. Upto 8-10 floors these operate at 1m/s and above 10 floors the speed starts at 2.5 m/s to 10 m/s.

• There are some types of passenger elevators:-

Sky lobbies- an intermediate interchange floor where people can change from an express elevator that stops only at the sky lobby to a local elevator which stops at every floor within a segment of the building.

Express elevators- An express elevator does not serve all floors. it moves between the ground floor and a sky lobby.

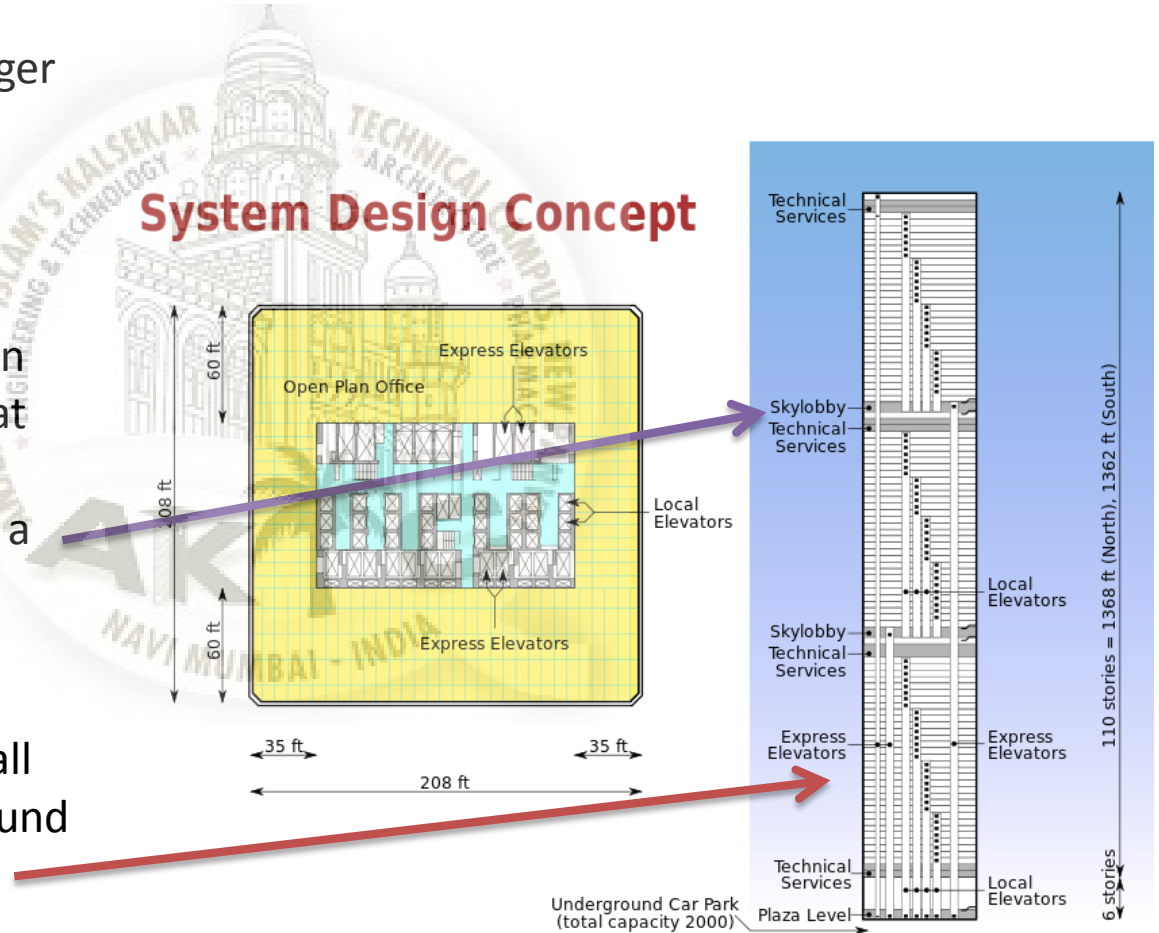

Passenger lift

Hospital

Residential

Hotel

Office

Institution



Service By KRRC (Central Library)



Hospital lifts

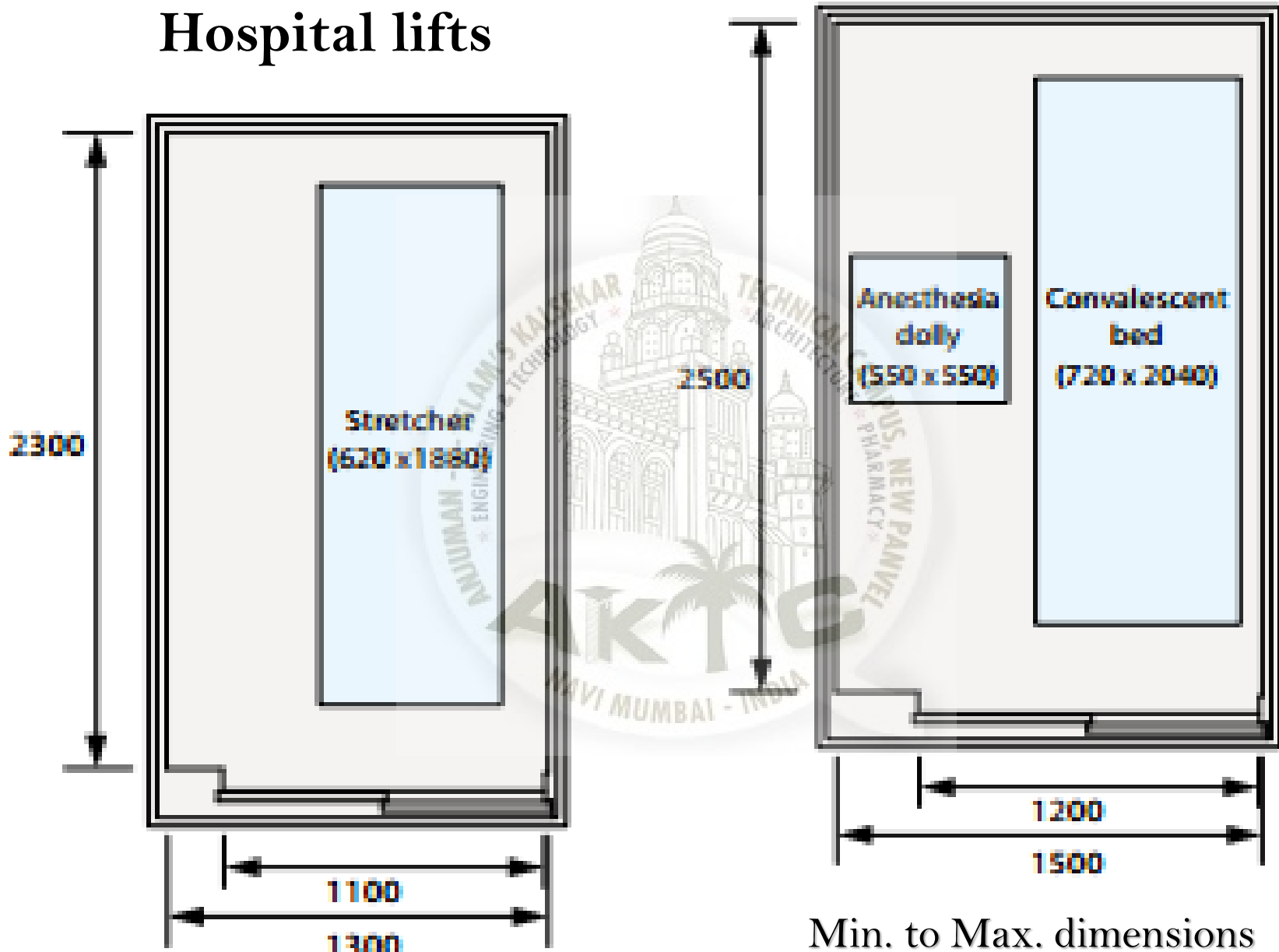

Min. to Max. dimensions

(mainly for Hotels)

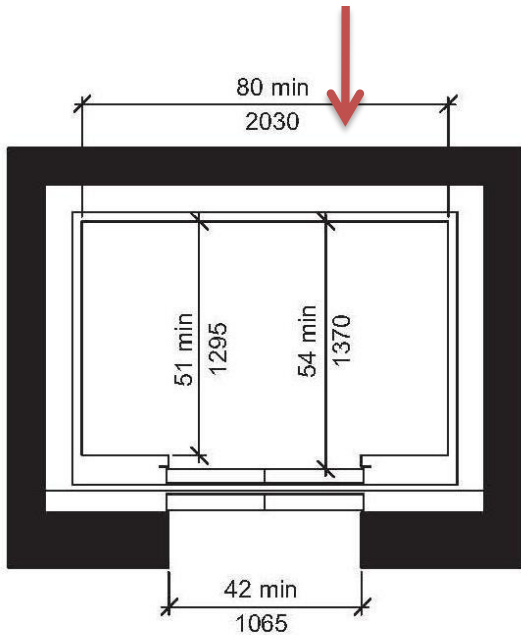

(a) Centered Door Location

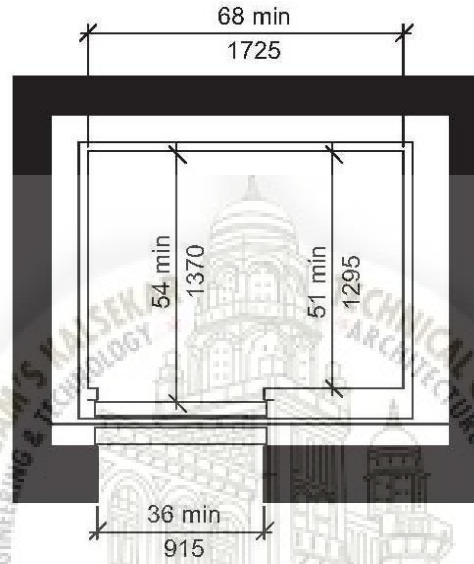

(b) Off-Centered Door Location

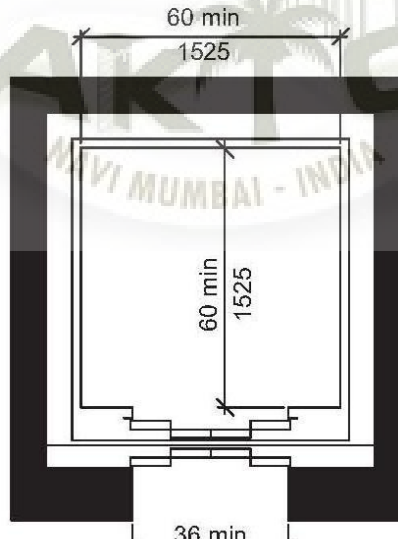
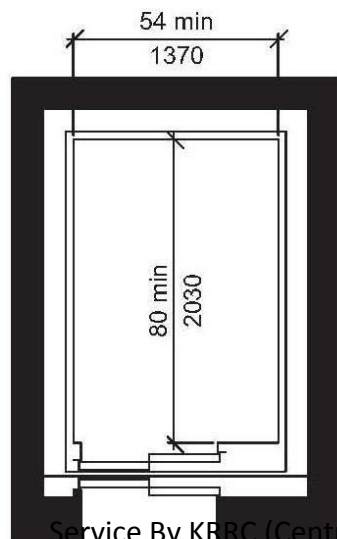
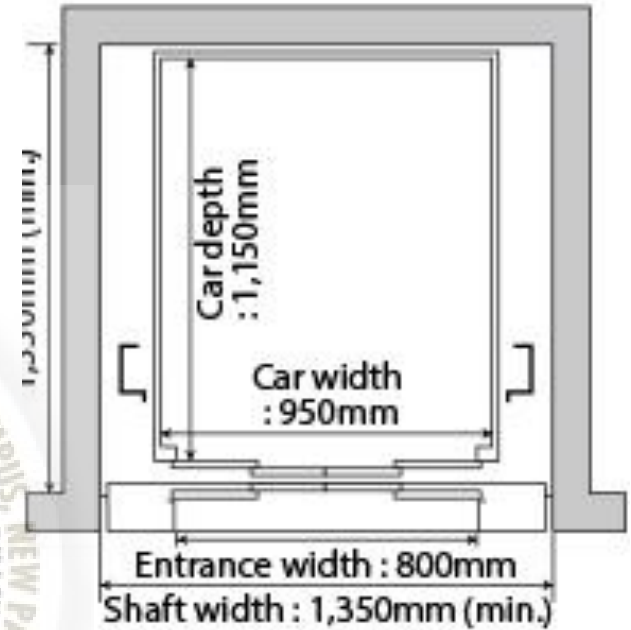

Min. to Max dimensions for Passenger lifts

2. Goods/Freight lifts

- Used to transport heavy goods but depends on types of good transported.
- Usually used in shopping complex, airports, hotels, warehouse.



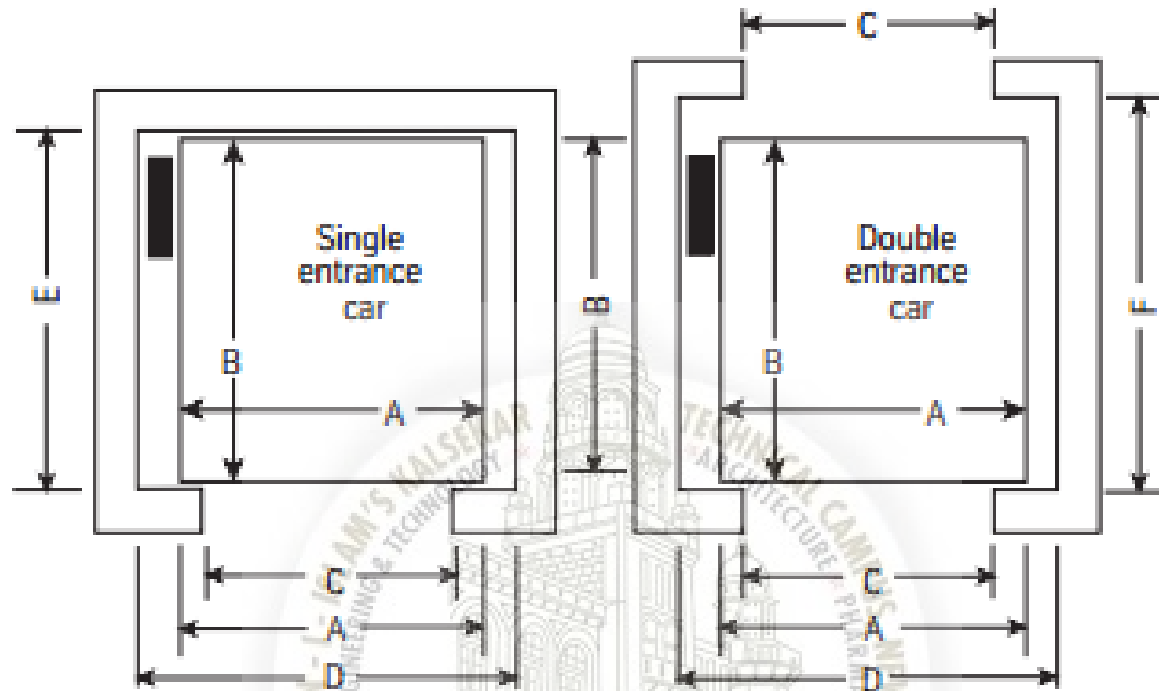

2500 (1134 kg) 4000 (1814 kg) 8000 (3629 kg) 10,000 (4536 kg)
 5000 (2268 kg)
 6000 (2722 kg)

A	5'-4" (1626)	8'-4" (2540)	8'-4" (2540)	8'-4" (2540)
B	7'-0" (2134)	10'-0" (3048)	12'-0" (3658)	14'-0" (4267)
C	5'-0" (1524)	8'-0" (2438)	8'-0" (2438)	8'-0" (2438)
D	7'-10" (2388) ¹	10'-10" (3302) ¹	11'-0" (3353) ²	11'-0" (3353) ²
E ²	7'-8" (2337)	10'-8" (3251)	12'-8" (3861)	14'-8" (4470)
F ⁴	7'-11" (2413)	10'-11" (3327)	12'-11" (3937)	14'-11" (4547)

Max. to Min. Goods lift

dimension

3. Vehicle lifts

- Used specifically to lift a car in multi storey car park or showroom.
- had to be in the form of traction and hydraulics.
- Form of traction is more commonly used for high velocity.

Type & No. of Vehicles	Load (kgs.)	Car Inside (width X Length)	Lift Shaft (one Side Open) (width X Length)	Enterece (width X Height)
3 Two Wheelers	500	1200 X 2400	2000 X 2800	1000 X 2000
4 Two Wheelers	750	1500 X 2400	2300 X 2800	1300 X 2000
Small Cars	1200	2300 X 5000	3050 X 5250	2100 X 2000
Mid Sized Cars	2000	2400 X 5100	3150 X 5350	2200 X 2000
Luxury Cars	3000	2700 X 5400	3450 X 5800	2400 X 2200
S.U.V.	4000	3000 X 5750	3800 X 6050	2400 X 2200
L.C.V. / Bus	10000	3500 X 7300	4400 X 7700	3000 X 3000

4. Dumbwaiter lifts

IR@AIKTC

aiktcdspace.org

- Dumbwaiters are small freight elevators that are intended to carry food rather than passengers.
- They often link kitchens with other rooms.
- When installed in restaurants, schools, kindergartens, hospitals, retirement homes or in private homes, the lifts generally terminate in a kitchen.
- Avg height of the car ranges from 0.8m to 1.2m.



Service By KRRC (Central Library)

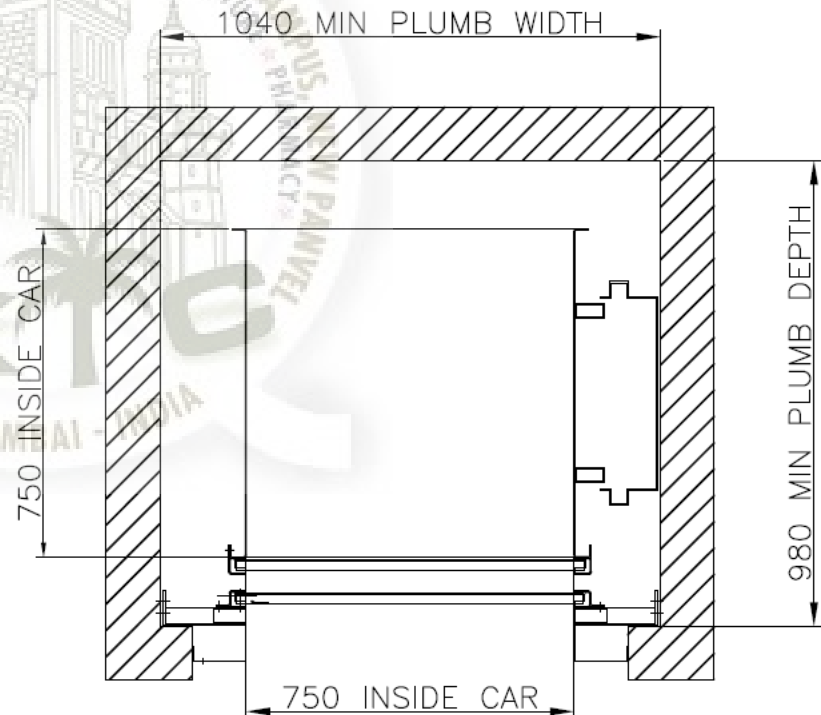

PLAN OF CAR IN SHAFT

5. Scissor lifts

- these lifts are self-contained, these lifts can be easily moved to where they are needed.
- they're excellent for indoor and outdoor construction, maintenance and installation applications.

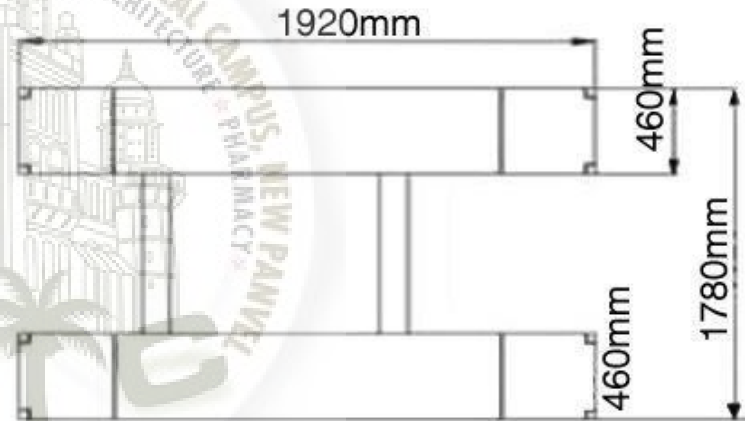
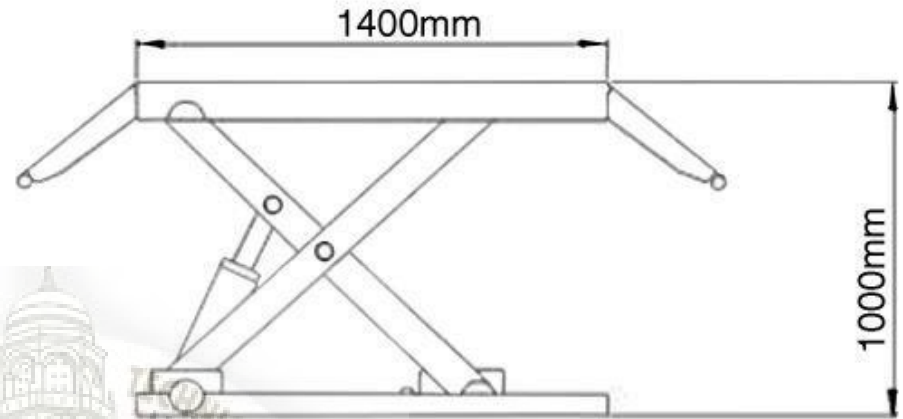

Features:

- High load bearing capacity
- Long life
- Smooth operations

Capacity	500 kg	1000 kg	1500 kg	2000 kg
Platform	1200 X 610	1800 X 1000	1800 X 1000	2500 X 1800
Clear lift	700	1100	1100	1650
Elevated Height	1000	1500	1500	2050
Closed Height	300	400	400	400

IR@AIKTC

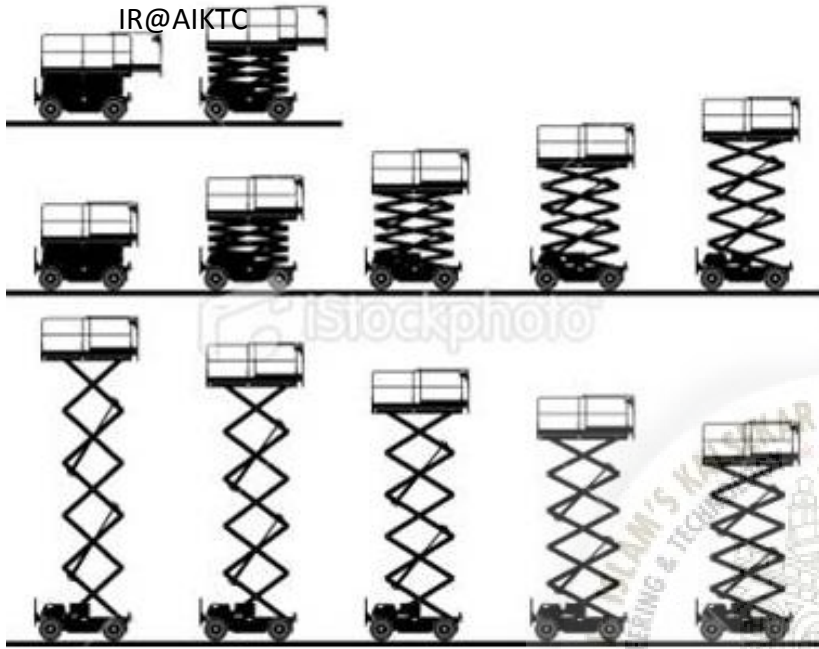

aiktcdspace.org



Service By KRRC (Central Library)

Openings

Centre opening sliding



Collapsible



Single sliding

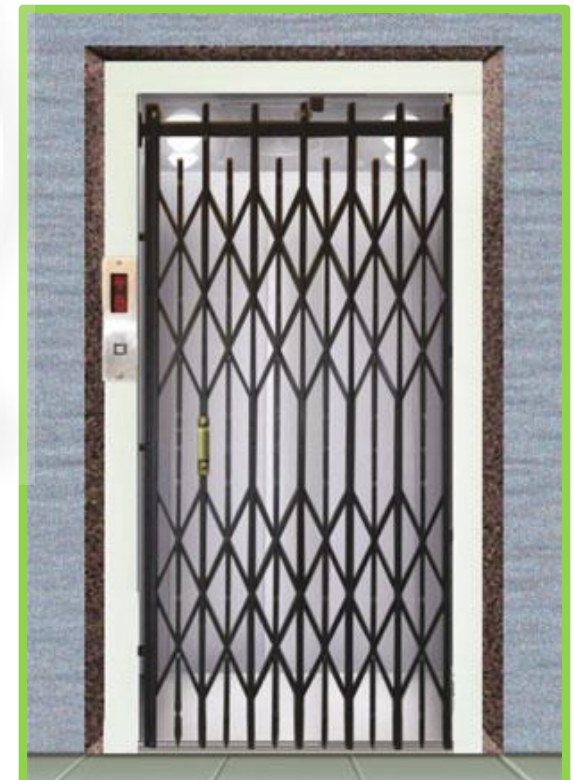

1.8 : Lift Installation by zone system

ONE SYSTEM ZONE

- For building not > 15 levels.
- Elevators car stops at every level of the building.
- Used to save space.

TWO SYSTEM ZONE

- For buildings > 15 levels and < 40 levels.
- System brake into two zone of elevator
- The elevator of bottom and same for the top will not stop at any lower zone.
- Not effective in the event of 'off peak' and interfloor service.

SKY LOBBY ZONE

- For building > 40 levels.
- A group lift with high speed moving lift without interruption from the floor to the sky lobby.
- The elevator will move with normal velocity at the next level.

System Design Concept

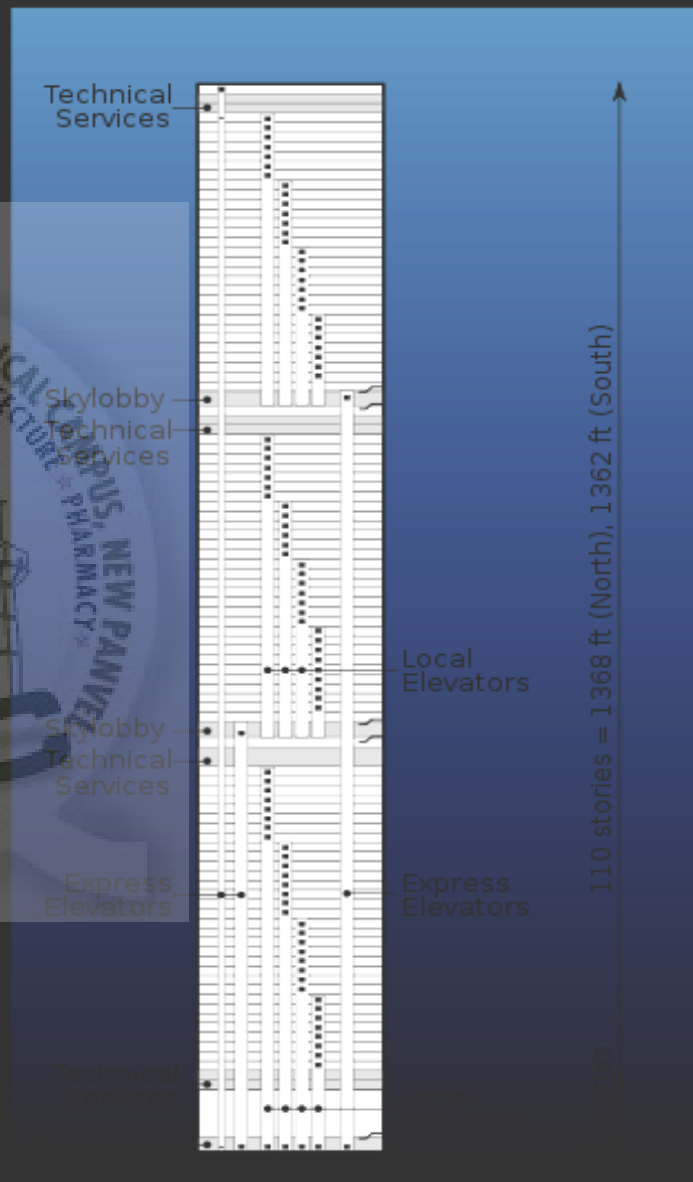
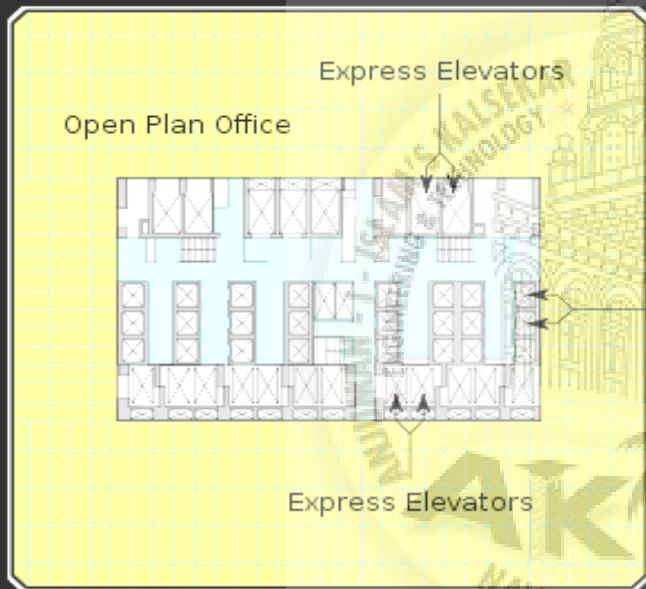

What is Escalator ?

A moving staircase – a conveyor transport device for carrying people between floors of a building.

consists of a motor-driven chain of individual, linked steps that move up or down on tracks, allowing the step treads to remain horizontal.

are used to move pedestrian traffic in places where elevators would be impractical like shopping malls, airports, convention centers.



Components

Landing platform

Truss

Steps

Tracks

Handrail

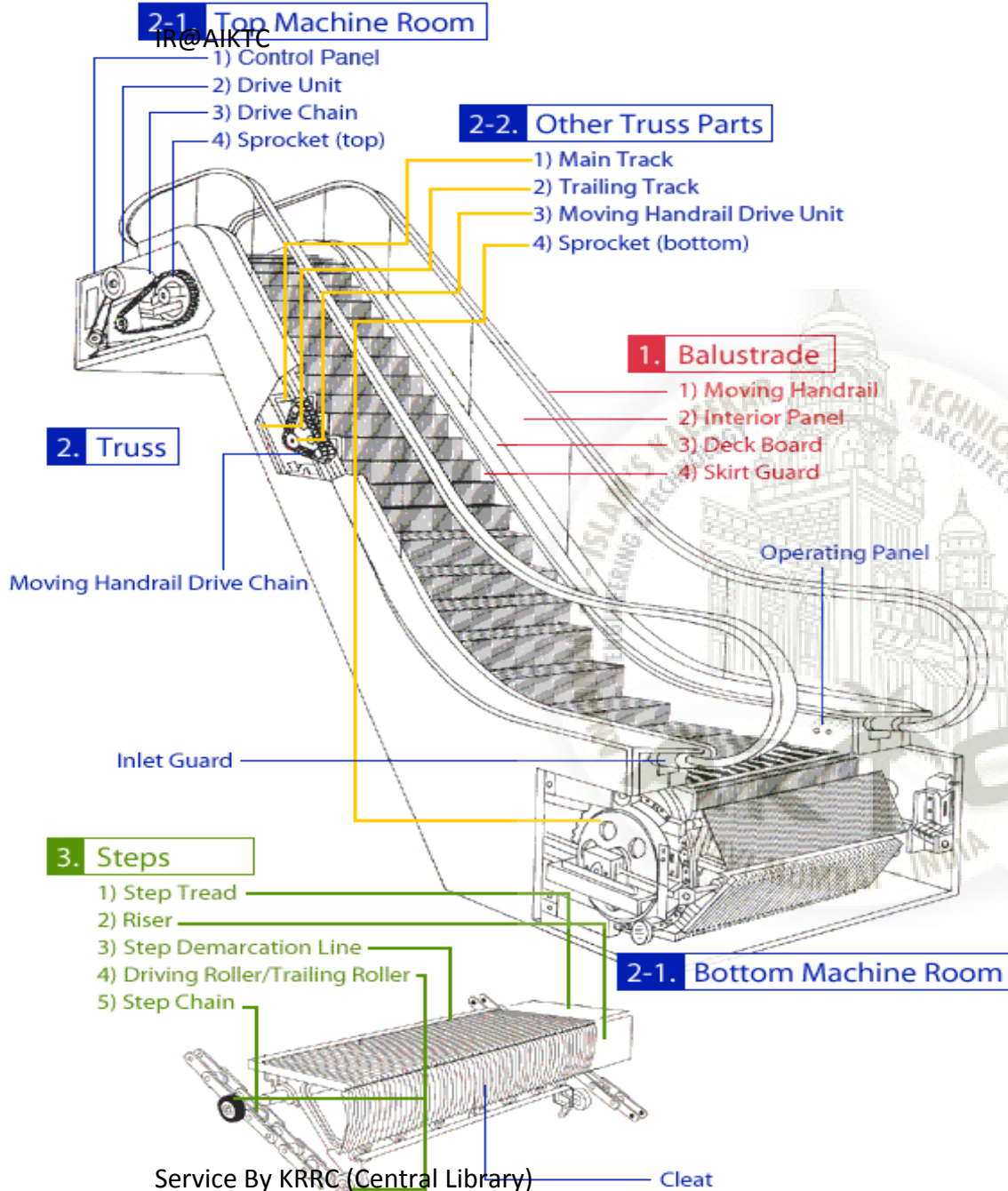

Service By KRRC (Central Library)

How Escalators Work

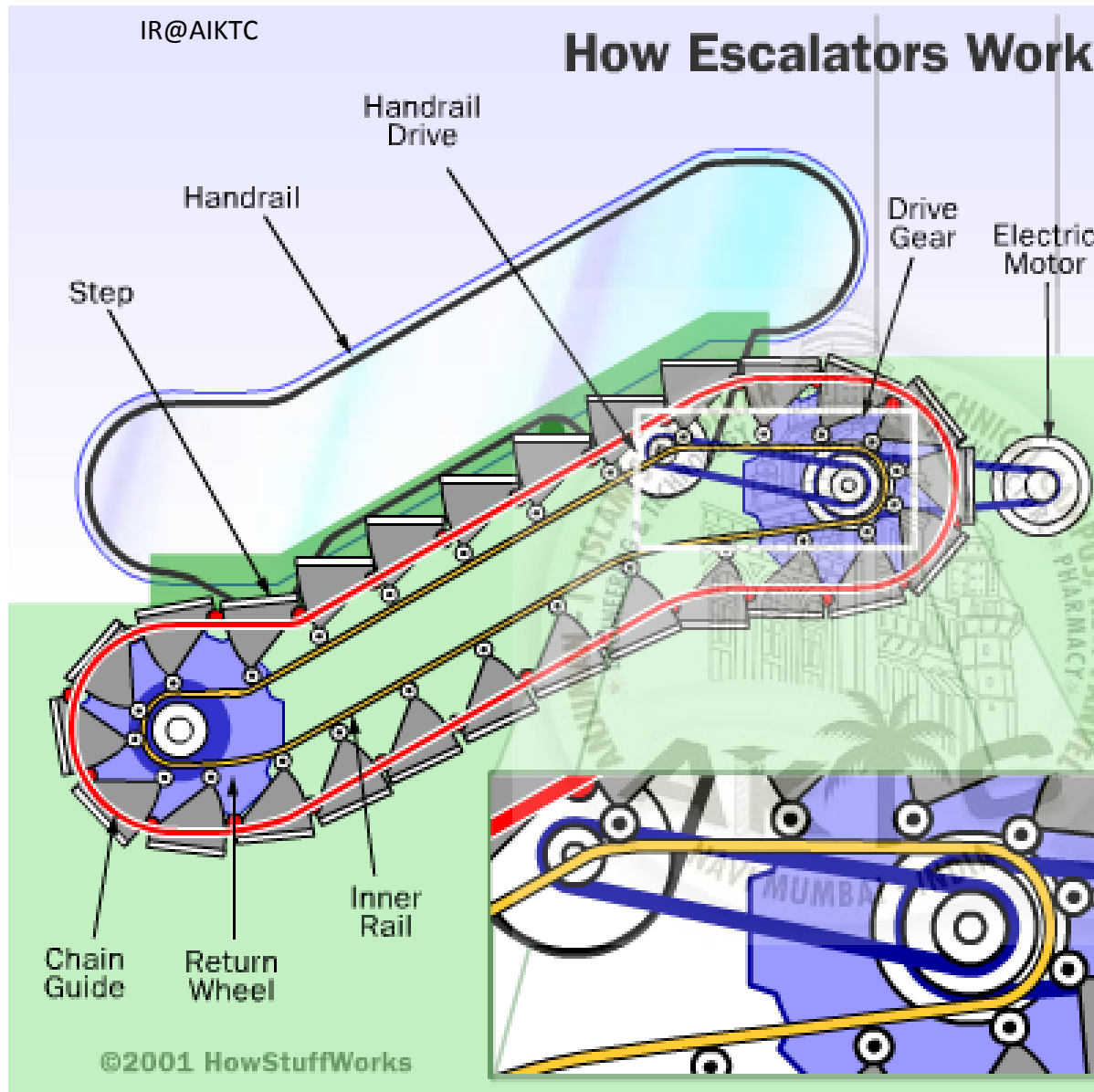

©2001 HowStuffWorks

- The core of an escalator is a pair of chains, looped around two pairs of gears & an electric motor runs it.

- The motor and chain system are housed inside the truss, a metal structure extending between two floors.

- As the chains move, the steps always stay level.

- At the top and bottom of the escalator, the steps collapse on each other, creating a flat platform. This makes it easier to get on and off the escalator.

Conventional Mechanism

Service by IRVCC Digital Library

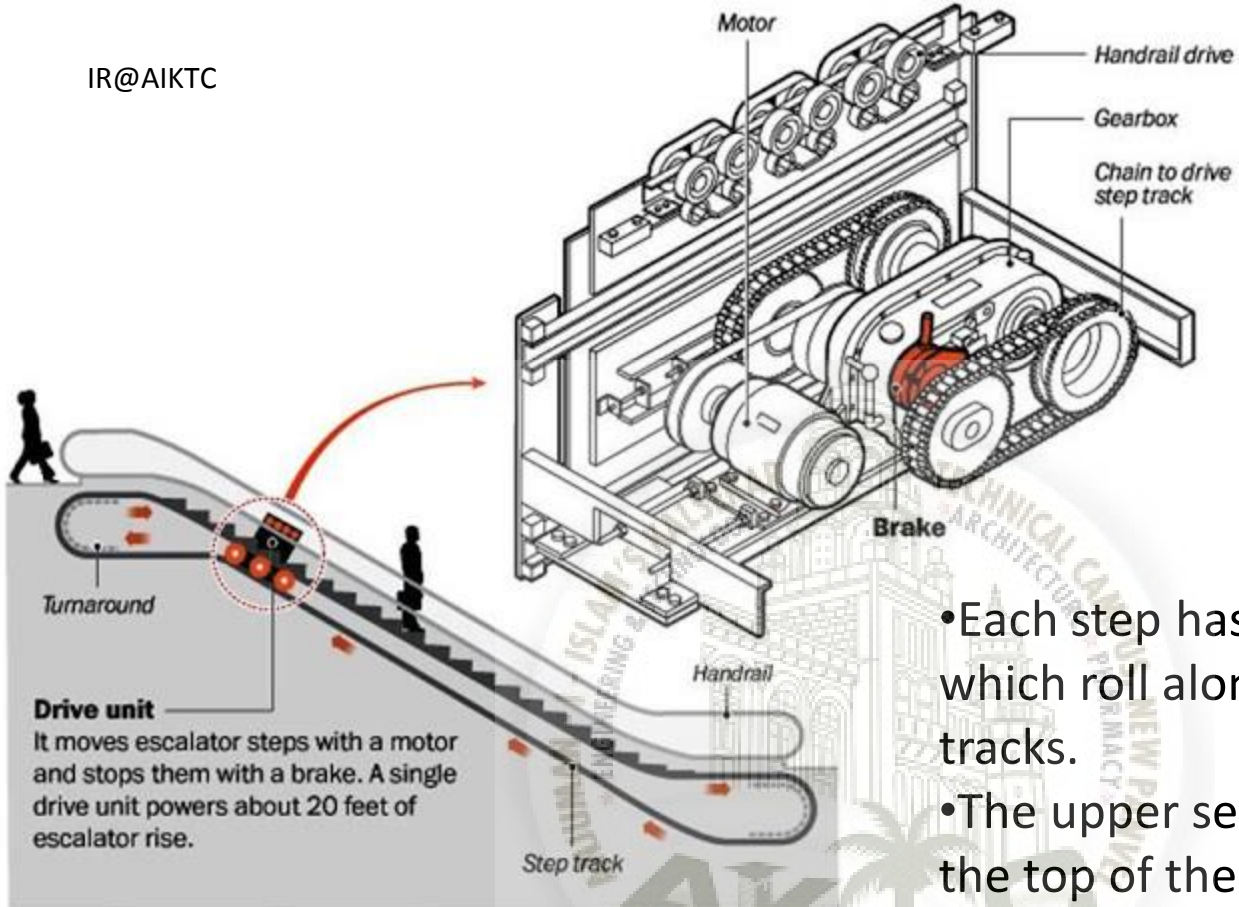

Drive unit
It moves escalator steps with a motor and stops them with a brake. A single drive unit powers about 20 feet of escalator rise.

Modern Mechanism

- the electric motor also moves the handrail, a rubber conveyer belt, moves at exactly the same speed as the steps, to give riders some stability.

- Each step has two sets of wheels, which roll along two separate tracks.
- The upper set (the wheels near the top of the step) are connected to the rotating chains.
- The other set simply glides, following behind the first set.
- Each step has a series of grooves in it, so it will fit together with the steps behind the tracks.

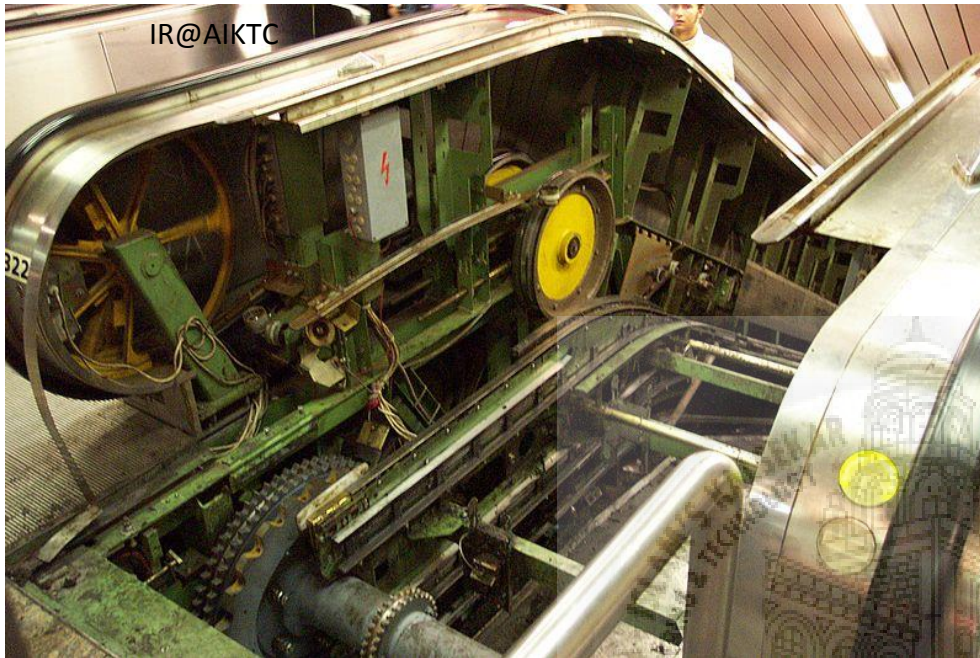

Escalator truss connects to the landing platform (lower left).

Also visible: exposed drive gears (center) for steps and handrail drive (left)

View of escalator steps on continuous chain



Diff. sizes & its applications

Size	Width (between balustrade panels)	Single-step capacity	Applications
Very very small	400 mm (16 in)	One passenger, with feet together	A rare historic design found mostly in older department stores
Small	600 mm (24 in)	One passenger	Low-volume sites, uppermost levels of department stores, when space is limited
Medium	800 mm (31 in)	One passenger + one package or one piece of luggage	Shopping malls, department stores, smaller airports
Large	1,000 mm (39 in)	Two passengers – one may walk past another	Mainstay of metro systems, larger airports, train stations, some retail usage and in sky train



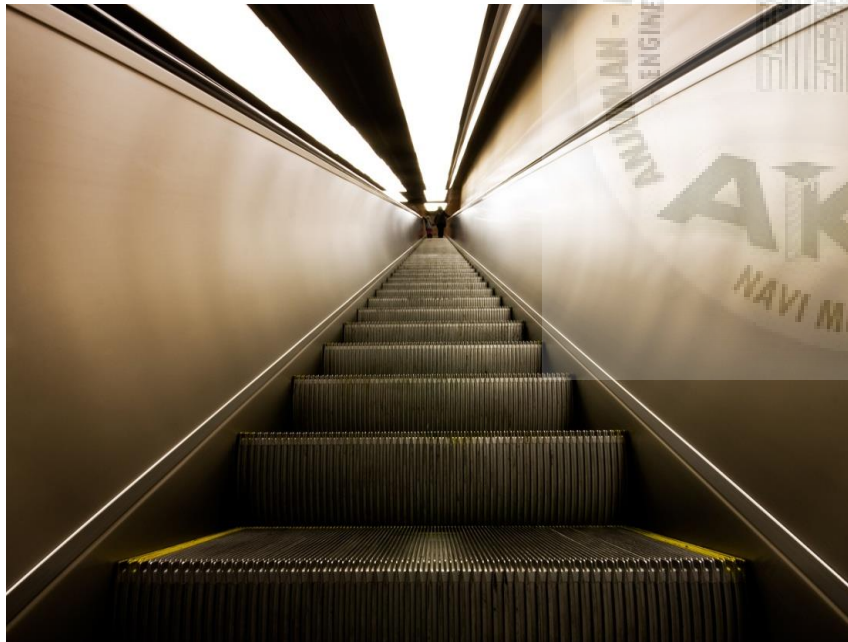
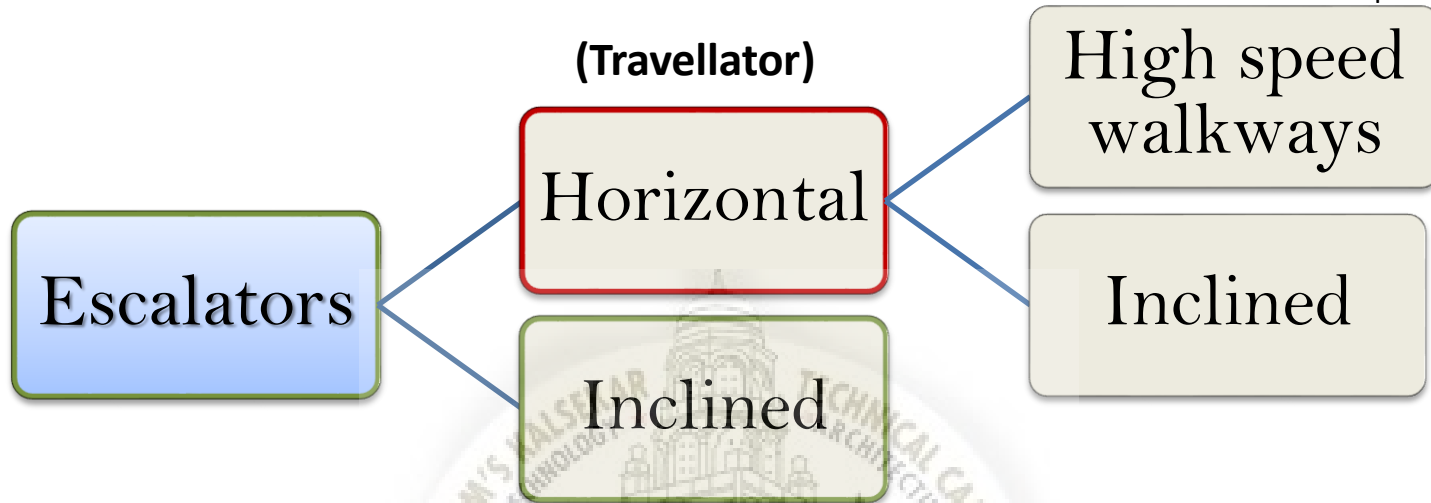

Service By KRRC (Central Library)

IR@AIKTC

Moving walkways – Travellator

aiktcdspace.org

- a slow moving conveyor mechanism that transports people across a **horizontal or inclined plane** over a short to medium distance.

- can be used by standing or walking on them. They are often installed in pairs, one for each direction.

- are built in one of two basic styles:
Pallet type — a continuous series of flat metal plates join together to form a walkway. Most have a metal surface.

- Moving belt** — these are generally built with mesh metal belts or rubber walking surfaces over metal rollers.



Service By KRRC (Central Library)

Faculty: Sujit Parab | Semester-6 | Building Services | Vertical Transportation | 2017-18

High speed walkways

- Using the high-speed walkway is like using any other moving walkway, except that for safety there are special procedures to follow when joining or leaving.
- riders must have at least one hand free to hold the handrail, those carrying bags, shopping, etc., or must use the ordinary walkway nearby.
- Riders stand still with both feet on the metal rollers and let it pull them so that they glide over the rollers.

Inclined moving walkways

- is used to move people to another floor so that people can take along their suitcase trolley or shopping cart, or baby carriage.
- The carts have either a brake that is automatically applied, strong magnets in the wheels to stay adhered to the floor, or specially designed wheels that secure the cart within the grooves of the ramp, so that wheeled items travel alongside the riders and do not slip away.



STH horizontal



STA inclined



Service By KRRC (Central Library)

IR@AIKTC

Applications

Airport

Zoo

Theatre

Museum

Malls

Theme
park



Skiers on a moving walkway



Service By KRRCC (Central Library)

Difference between Lifts & Escalators

Lifts (Elevators)	Escalators
<ul style="list-style-type: none"> •closed cabins inside vertical shafts that are used to transport people between different floors in high rise buildings. 	<ul style="list-style-type: none"> •moving stairways that allow people to move between floors in busy places such as shopping malls, airports, and railway stations.
<ul style="list-style-type: none"> •Lifts are fast and can move up or down at great speeds....vertical movement. 	<ul style="list-style-type: none"> •These are slow moving.....horizontal & incline movement.
<ul style="list-style-type: none"> •move up or down using counterweights or traction cables. 	<ul style="list-style-type: none"> •The steps of are fixed and linked together and move up but come down from behind on a conveyor belt that is driven by a motor.
<ul style="list-style-type: none"> •Less space is used for its construction as the elevator is limited to the shaft & machine room, which connects all the floors. 	<ul style="list-style-type: none"> •Space used is same as the staircases & connects 2 floors .

Lifts

- Limited number of people can accommodate at a time.

- If there is electricity cut-outs then it doesn't work.

Escalators

- There is no waiting period as one can set foot anytime to climb up or come down.

- Its very versatile, if there is electric cut-outs then one can climb those steps, which acts like a staircase.

- Schindler
- Otis
- Fujitec
- Kinetic
- Express
- Noble
- Omega

Different
Companies

