



AIKTC/KRRC/SoET/ACKN/QUES/2018-19/

Date: _____

School: SoET-CBCS

Branch: ALL BRANCHES

SEM: I

To,
Exam Controller,
AIKTC, New Panvel.

Dear Sir/Madam,

Received with thanks the following [✓]Semester/[✓]Unit Test-I/[✓]Unit Test-II (Reg./ATKT) question papers from your exam cell:

Sr. No.	Subject Name	Subject Code	Format		No. of Copies
			SC	HC	
1	Applied Mathematics- I	FEC101		✓	02
2	Applied Physics- I	FEC102		✓	02
3	Applied Chemistry- I	FEC103		✓	02
4	Engineering Mechanics	FEC104		✓	02
5	Basic electrical & electronic Engineering	FEC105			
6	Environmental studies	FEC106		✓	02

Note: SC – Softcopy, HC - Hardcopy

(Shaheen Ansari)
Librarian, AIKTC

(3 Hours)

[Total marks : 80

- Note** :-
- 1) Question number 1 is **compulsory**.
 - 2) Attempt any **three** questions from the remaining **five** questions.
 - 3) **Figures** to the **right** indicate **full marks**.

Q.1 a) If $u = \log\left(\frac{x}{y}\right) + \log\left(\frac{y}{x}\right)$, find $\frac{\partial u / \partial x}{\partial u / \partial y}$ 03

b) Find the value of $\tanh(\log x)$ if $x = \sqrt{3}$ 03

c) Evaluate $\lim_{x \rightarrow 3} \left[\frac{1}{x-3} - \frac{1}{\log(x-2)} \right]$ 03

d) If $u = r^2 \cos 2\theta$, $v = r^2 \sin 2\theta$, find $\frac{\partial(u,v)}{\partial(r,\theta)}$ 03

e) Express the matrix $A = \begin{pmatrix} 2 + 3i & 2 & 3i \\ -2i & 0 & 1 + 2i \\ 4 & 2 + 5i & -i \end{pmatrix}$ as the sum of a 04

Hermitian and a Skew-Hermitian matrix.

f) Expand $\tan^{-1}x$ in powers of $\left(x - \frac{\pi}{4}\right)$ 04

Q.2 a) Expand $\sin^7 \theta$ in a series of sines of multiples of θ 06

b) If $y = \sin^2 x \cos^3 x$, find y_n 06

c) Find the stationary values of $x^3 + y^3 - 3axy$, $a > 0$ 08

Q.3 a) Compute the real root of $x \log_{10} x - 1.2 = 0$ correct to three places of decimals using Newton-Raphson method. 06

b) Show that the system of equations 06
 $2x - 2y + z = \lambda x$, $2x - 3y + 2z = \lambda y$, $-x + 2y = \lambda z$
 can possess a non-trivial solution only if $\lambda = 1, \lambda = -3$. Obtain the general solution in each case.

c) If $\tan(\alpha + i\beta) = \cos \theta + i \sin \theta$, prove that 08
 $\alpha = \frac{n\pi}{2} + \frac{\pi}{4}$ and $\beta = \frac{1}{2} \log \tan\left(\frac{\pi}{4} + \frac{\theta}{2}\right)$

- Q. 4 a) Using the encoding matrix as $\begin{pmatrix} 1 & 1 \\ 0 & 1 \end{pmatrix}$, encode and decode the message MOVE. 06
- b) If $u = f(e^{x-y}, e^{y-z}, e^{z-x})$ then prove that $\frac{\partial u}{\partial x} + \frac{\partial u}{\partial y} + \frac{\partial u}{\partial z} = 0$ 06
- c) If $y = a \cos(\log x) + b \sin(\log x)$, then show that $x^2 y_{n+2} + (2n+1)xy_{n+1} + (n^2+1)y_n = 0$ 08
- Q. 5 a) If $1, \alpha, \alpha^2, \alpha^3, \alpha^4$, are the roots of $x^5 - 1 = 0$, find them and show that $(1-\alpha)(1-\alpha^2)(1-\alpha^3)(1-\alpha^4) = 5$ 06
- b) If $\theta = t^n e^{-r^2/(4t)}$, Find n which will make $\frac{\partial \theta}{\partial t} = \frac{1}{r^2} \frac{\partial}{\partial r} \left(r^2 \frac{\partial \theta}{\partial r} \right)$ 06
- c) Find the root (correct to three places of decimals) of $x^3 - 4x - 9 = 0$ lying between 2 and 3 by using Regula-Falsi method. 08
- Q. 6 a) Find non-singular matrices P and Q such that $A = \begin{pmatrix} 1 & 2 & 3 & 2 \\ 2 & 3 & 5 & 1 \\ 1 & 3 & 4 & 5 \end{pmatrix}$ is reduced to normal form. Also find its rank. 06
- b) Find the principle value of $(1+i)^{1-i}$ 06
- c) Solve the following equations by Gauss-Seidel method $27x + 6y - z = 85$ $6x + 15y + 2z = 72$ $x + y + 54z = 110$ (Take three iterations) 08

141

3/6/19

(2 Hours)

[Total Marks: 60]

1. Q. No.1 is compulsory.
2. Attempt any three from Q.No.2 to Q.No.6.
3. Assume suitable data wherever required.
4. Figures to the right indicate maximum marks.

- Q1. Answer any five from the following questions. (3 marks each) [15]
- a. Draw the following for a cubic unit cell. $(\bar{1} \bar{2} \bar{3})$, $(2 0 0)$, $(\bar{2} \bar{3} 0)$
 - b. Show that the Fermi energy level lies at the centre of the band gap in intrinsic semiconductors.
 - c. The mobility of hole is $0.025 \text{ m}^2/\text{V.s}$. What would be the resistivity of p-type Si sample if its Hall coefficient is $2.25 \times 10^{-5} \text{ m}^3/\text{C}$?
 - d. Explain de Broglie's hypothesis of matter waves and deduce the expression for λ .
 - e. Explain reverberation of sound.
 - f. Explain Meissner Effect with the help of diagram.
 - g. Discuss any three applications of Ultrasonic waves.
- Q2. a. Derive Bragg's equation for X-ray diffraction in crystals. Calculate the glancing angle on a plane $(1 0 0)$ of rock salt having lattice constant 2.814 \AA corresponding to first order Bragg's diffraction maximum for X-rays of wavelength 1.541 \AA . [8]
- b. What is Hall Effect? Derive an expression for Hall voltage. How can mobility be determined by using Hall Effect? [7]
- Q3. a. Derive the relation between density and lattice constant for a cubic crystal. Calculate the lattice constant, atomic radius and packing factor for Chromium having BCC structure. Given density of Chromium is 5.98 gm/cc and atomic weight is 50 [8]
- b. Explain the formation of P-N junction in equilibrium with energy band diagram and explain its conduction process in forward bias. [7]
- Q4. a. Differentiate between Type-I & Type-II Superconductors. [5]
- b. Discuss in details any three factors affecting acoustics of a hall with their remedies [5]
- c. Calculate the de Broglie wavelength of alpha particles accelerating through a potential difference of 150 volts. Given mass of Alpha particle is $6.68 \times 10^{-27} \text{ Kg}$. [5]
- Q5. a. Find the accuracy in the position of an electron moving with speed 350 m/sec with uncertainty of 0.01%. [5]
- b. A quartz crystal of thickness 1 mm is vibrating at resonance. Calculate its fundamental frequency. (Assume that for quartz, $Y = 7.9 \times 10^{10} \text{ N/m}^2$ and $\rho = 2.650 \text{ gm/cc}$.) [5]
- c. Calculate electron & hole concentration in intrinsic Si at room temperature if its electrical conductivity is $4 \times 10^{-4} \text{ mho/m}$. Given that mobility of electron = $0.14 \text{ m}^2/\text{V-sec}$ and mobility of holes = $0.04 \text{ m}^2/\text{V-sec}$. [5]
- Q6. Write short notes on the following (any three) [15]
- a. Davisson- Germer Experiment
 - b. Maglev
 - c. Bragg's spectrometer
 - d. Crystal defects

104

20/5/19

Time : 2 Hrs

Marks : 60

- N.B.
1. Question No.1 is compulsory.
 2. Attempt any three from Q.2 to Q.6
 3. Draw neat diagram and write chemical reactions where necessary.
 4. Figures to right indicate full marks.

Atomic weights:

H = 1, C = 12, N = 14, O = 16, Na = 23, Mg = 24, S = 32, Cl = 35.5, K = 39, Ca = 40

- Q.1]** Answer any five from the following:- 15
- (a) Write a brief note on Reverse Osmosis.
 - (b) Write methods of preparation, properties and uses of polyurethane rubber.
 - (c) Define and discuss giving significance of the following
(i) Viscosity (ii) Cloud Point
 - (d) Write advantages and drawback of Phase Rule.
 - (e) A hard water sample contains following impurities (in mg/L)
Mg(HCO₃)₂ = 150 ; NaCl = 77 ; CaCl₂ = 135; MgSO₄ = 85.
Calculate temporary, permanent and total hardness of the given sample of water.
 - (f) Discuss the effect of temperature on polymers.
 - (g) Why gypsum is added during manufacturing of the cement?
- Q.2]** A hard water sample has following composition 6
- (a) CaSO₄ = 170mg/L; Ca(HCO₃)₂ = 130mg/L; Mg(HCO₃)₂ = 95mg/L;
HCl = 58mg/L; KNO₃ = 75mg/L
Calculate lime (90% pure) and soda (95% pure) required for complete softening of one million liters of above hard water sample.
 - (b) (i) What is Glass transition temperature? 3
(ii) What are semi solid lubricants? Under which conditions they are used? 2
 - (c) Explain briefly Carbon nanotubes by CVD method. 4
- Q.3]** What is Natural rubber? What is vulcanized of rubber? Compare the properties 6
- (a) of vulcanized rubber over natural rubber.
 - (b) (i) What is 'Triple Point'? Write the condition at which triple point exists for water system. 3
(ii) What are Fullerenes? Write important properties and uses of Fullerene. 2

[3 Hours]

[Marks 80]

NB:

1. Question No: 1 is compulsory.
2. Attempt any three questions out of remaining five questions.
3. Assume suitable data if necessary and mention the same clearly.
4. Draw suitable sketches whenever necessary.

i. Attempt Any Four :

- a) Find the resultant of forces as shown in fig.

(05)

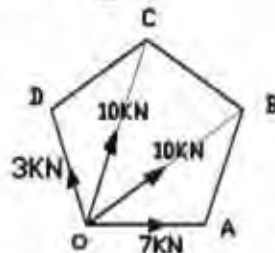

- b) If the cords suspend the two buckets in equilibrium position shown in Fig. Determine weight of bucket B if Bucket A has a weight of 60N.

(05)

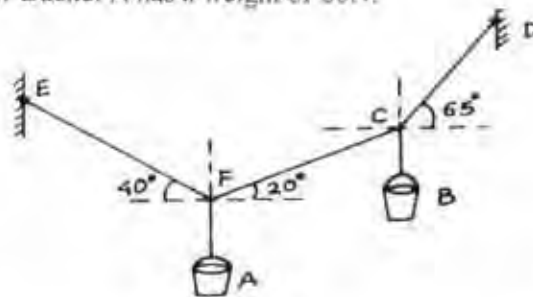

- c) Two blocks A=100N and B=150N are resting on the ground as shown in the fig. Find the minimum weight P in the pan so that body A starts. Assume pulley to be mass less and frictionless.

(05)

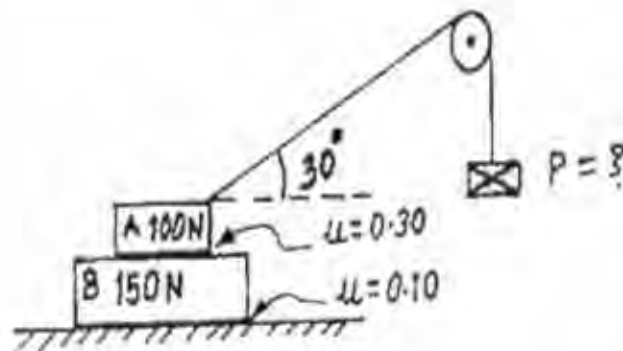

2

- d) The motion of jet plane while travelling along a runway is defined by the $v-t$ graph as shown in Fig. Construct the $s-t$ graph for the motion. The plane starts from rest. (05)

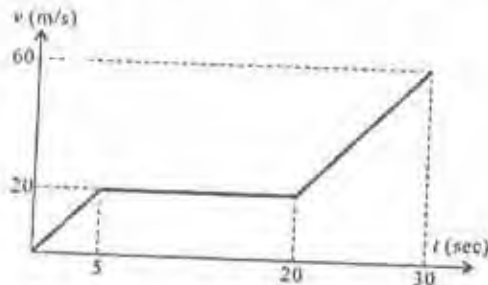

- (c) A 50 kg block is kept on the top of a 15° sloping surface is pushed down the plane with an initial velocity of 20m/s. If $\mu_k = 0.4$, determine the acceleration of the block. (05)

2. Attempt:

- a) Four forces acting on a rectangle in the same plane as shown in fig below. Find magnitude and direction of the resultant force. Also find intersection of line of action of resultant with X and Y axes, assuming D as origin. (06)

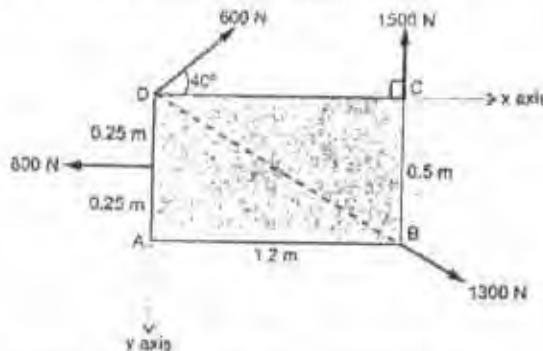

- b) Two spheres A and B of weight 1000N and 750N respectively are kept as shown in fig. Determine the reactions at all contact points 1, 2, 3 and 4. Radius of A = 400 mm and B = 300 mm. (08)

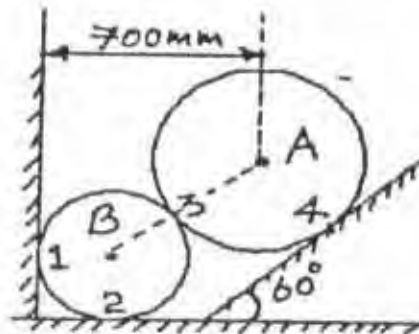

3

- c) Two smooth balls A (mass 3 kg) and B (mass 4kg) are moving with velocities 25 m/s and 40 m/s respectively. Before impact, the directions of velocity of two balls are 30° and 60° with the line joining the centers as shown in Fig. If $e = 0.8$, find the magnitude and direction of velocities of the balls after impact. (06)

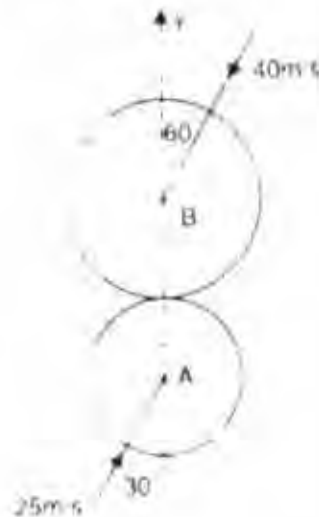

3. Attempt:

- a) Find the centroid of shaded area as shown in fig. (08)

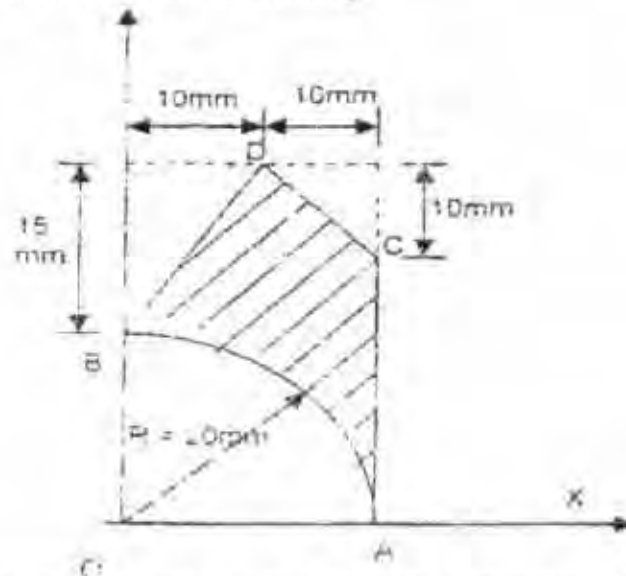

- b) Three forces F_1 , F_2 and F_3 act at the origin O. $F_1 = 70$ N acting along OA, where A (2, 1, 3). $F_2 = 80$ N acting along OB, where B (-1, 2, 0). $F_3 = 100$ N acting along OC, where C (4, -1, 5). Find the resultant of these concurrent forces. (06)

4

- c) A 4kg collar is attached to a spring, slides on a smooth bent rod ABCD. The spring has constant $k = 500 \text{ N/m}$ and is undeformed when the collar is at 'C'. If the collar is released from rest at A. Determine the velocity of collar, when it passes through 'B' and 'C'. Also find the distance moved by collar beyond 'C' before it comes to rest again. Refer Fig. (06)

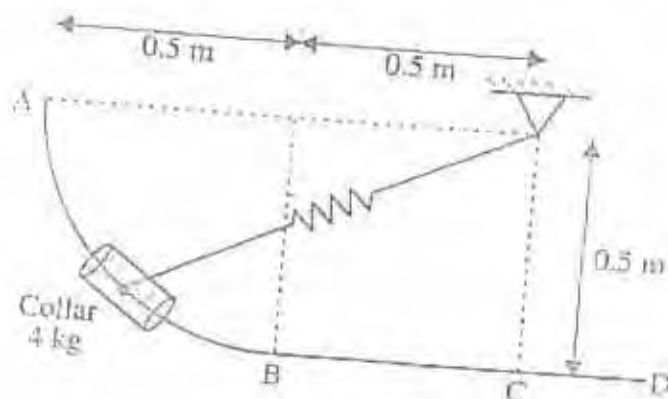

4. Attempt:

- a) Find the support reactions of beam loaded as shown in fig. (08)

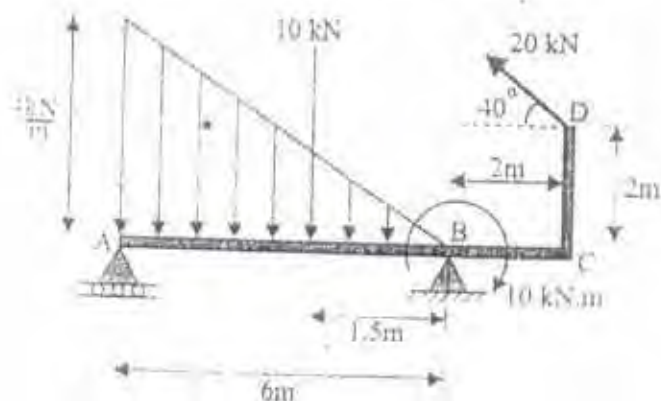

- b) Determine the moment to be applied at C for equilibrium of pin jointed mechanism. Use virtual work method. Refer Fig. (06)

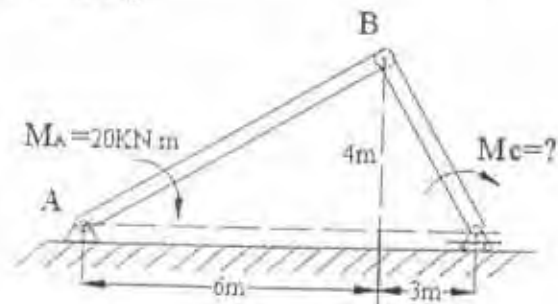

5

- c) A slider crank mechanism is shown in Fig. The crank OA rotates anticlockwise at 100 rad/s. Find the angular velocity of rod AB and the velocity of the slider at B. (06)

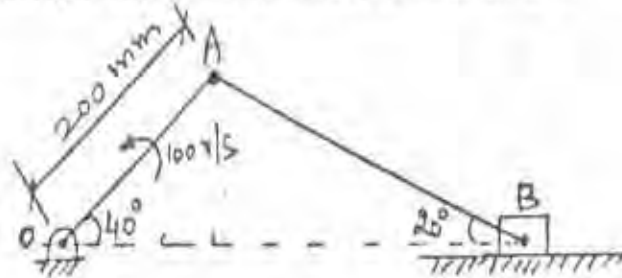

5. Attempt:

- a) Find the forces in the members BC, BE and AE by method of sections and remaining members by method of joints. (08)

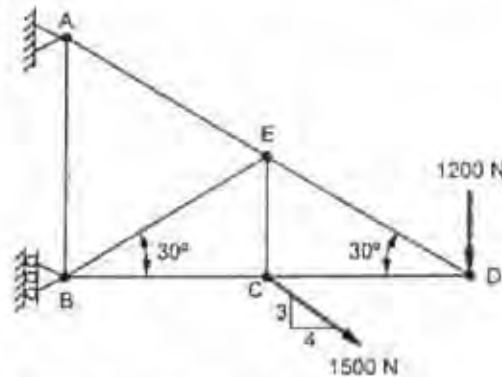

- b) A particle moves in x-y plane and its position is given by $r = (3t)\mathbf{i} + (4t - 3t^2)\mathbf{j}$, where r is the position vector of particle in meters at time t sec. Find the radius of curvature of the path and normal and tangential components of acceleration when it crosses X-axis again. (06)
- c) C is a uniform cylinder to which a rod AB is pinned at A and the other end of the rod B is moving along a vertical wall as shown in Fig - 4. If the end B of the rod is moving upwards along the wall with a speed of 3.3 m/s find the angular velocity of wheel and rod assuming that cylinder is rolling without slipping. (06)

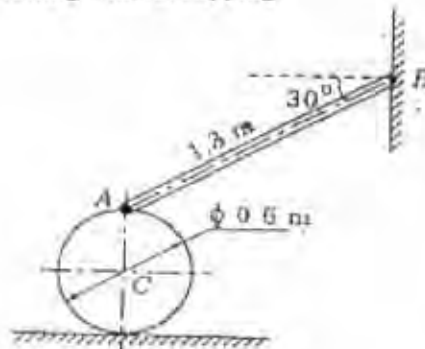

6. Attempt:

- a) A 100N uniform rod AB is held in position as shown. If $\mu=0.15$ at A and B calculate range of value of P for which equilibrium is maintained. (08)

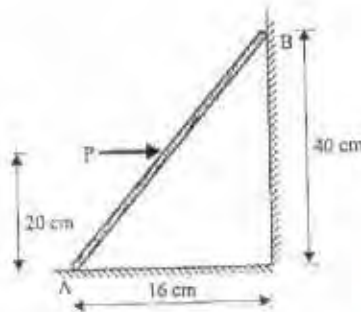

- b) A box of size 3 X 4 X 2m is subjected to three forces as shown in fig. Find in vector form the sum of moments of the three forces about diagonal OB. (06)

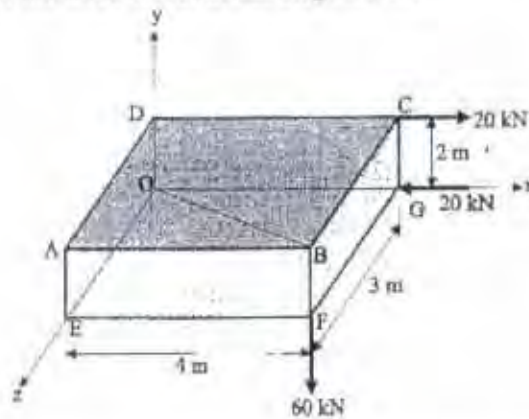

- c) Two blocks A and B are separated by 10 m as shown in Figure on a 20° incline plane. If the blocks start moving, find the time t when the blocks collide and distance travelled by each block. Assume $\mu_k = 0.3$ for block A and plane and $\mu_k = 0.10$ for block B and plane. (06)

Weight of Block A
 = 600 N
 Weight of Block B
 = 300 N

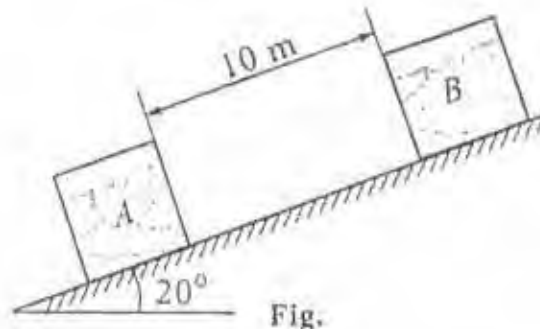

Fig.

23

10/6/19

(2 Hours)

(Total Marks : 60)

- N.B.:** (1) All questions are compulsory.
(2) Draw neat diagrams wherever necessary.
(3) Figures to the right indicate full marks.

- Q.1 Attempt any five from the following:- 15M
- a Define soil depletion. Give the classification of ecosystem.
 - b Define pollution. State any four sources of soil pollution.
 - c Give the functions (any six) of state pollution control board.
 - d Define and give any four objectives of Green building.
 - e Define geothermal energy. Draw a neat and labeled diagram of steam turbine power plant.
 - f Define and give any four limitations of conventional sources of energy.
 - g Define land pollution. State any two sources of soil pollution. Give any two adverse effects of soil pollution.
- Q.2 Attempt the following:- 15M
- (a) Give the reasons and consequences of cloudburst and landslides at Kedarnath. 4M
 - (b) Define noise pollution. State any four sources of noise pollution. State any four bad effects of noise pollution. Give the reactions taking place in the environment during acid rain. 5M
 - (c) Draw a neat and labeled diagram of electrostatic precipitator used for purification of air pollutants. Give the principle involved in electrostatic precipitator. Give any two advantages and disadvantages of electrostatic precipitator. 6M
- Q.3 Attempt the following:- 15M
- (a) Define indoor air pollution. State any four sources of indoor air pollution. State any four bad effects of indoor air pollution. 5M
 - (b) Draw neat and labelled diagram for solar heater. Give the principle involved in solar heater. Give the working of solar heater. 5M
 - (c) What is the meaning of sustainable development? Give any four social and economical aspects of sustainable development. 5M
- Q.4 Attempt the following:- 15M
- (a) Give the importance of environmental education. How does Biomass and energy flow are related in ecological pyramid? 4M

- (b) Draw a neat and labeled diagram of solar cell. Give the principle involved in solar cell. Give the construction of solar cell. Give any two advantages and disadvantages of solar cell. 6M
- (c) Explain the concept of control measures through the concept of Recover. Give the advantages and disadvantages of such program. 5M
- Q.5 Attempt the following:- 15M
- (a) Define wind energy. Give the principle involved in wind turbines. Give any two advantages and disadvantages of wind energy. Give the construction of wind turbine. 6M
- (b) Explain the case study of boiler blast tragedy in Dombivali MIDC. 4M
- (c) Define water pollution. State any four sources of water pollution. State any four bad effects of water pollution. 5M
- Q.6 Attempt the following:- 15M
- (a) Give the importance of environmental education from environmental degradation. Give the causes of depletion of natural water resources. 5M
Define photochemical smog. State any four sources of photochemical smog. State any
- (b) four bad effects of photochemical smog. 6M
- (c) Explain the case study of earthquake in Latur. 4M