



AIKTC/KRRC/SoET/ACKN/QUES/2018-19/

Date: _____

School: SoET-CBCS

Branch: ALL BRANCHES

SEM: II

To,
 Exam Controller,
 AIKTC, New Panvel.

Dear Sir/Madam,

Received with thanks the following [✓]Semester/[✓]Unit Test-I/[✓]Unit Test-II (Reg./ATKT) question papers from your exam cell:

Sr. No.	Subject Name	Subject Code	Format		No. of Copies
			SC	HC	
1	Applied Mathematics- II	FEC201		✓	02
2	Applied Physics- II	FEC202		✓	02
3	Applied Chemistry- II	FEC203		✓	02
4	Engineering Drawing	FEC204		✓	02
5	Structured Programming Approach	FEC205		✓	02
6	Comm. Skills- II	FEC206		✓	02

Note: SC – Softcopy, HC - Hardcopy

(Shaheen Ansari)
 Librarian, AIKTC

Duration – 3 Hours

Total Marks: 80

N.B 1) Question No. 1 is **Compulsory**.

2) **Answer** any **three** questions from remaining questions.

3) Figures to the right indicate full marks.

- Q.1**
- a) Evaluate $\int_0^{\infty} y^4 e^{-y^6} dy$. 3
 - b) Find the circumference of a circle of radius r by using parametric equations of the circle $x = r \cos \theta, y = r \sin \theta$. 3
 - c) Solve $(D^2 + D - 6)y = e^{4x}$. 3
 - d) Evaluate $\int_0^1 \int_{x^2}^x xy(x^2 + y^2) dy dx$. 3
 - e) Solve $(\tan y + x) dx + (x \sec^2 y - 3y) dy = 0$. 4
 - f) Solve $\frac{dy}{dx} = 1 + xy$ with initial condition $x_0 = 0, y_0 = 0.2$ by Euler's method. Find the approximate value of y at $x = 0.4$ with $h = 0.1$. 4
- Q.2**
- a) Solve $(D^2 - 4D + 3)y = e^x \cos 2x + x^2$. 6
 - b) Show that $\int_0^{\infty} \frac{\tan^{-1} ax}{x(1+x^2)} dx = \frac{\pi}{2} \log(1+a)$. 6
 - c) Change the order of integration and evaluate $\int_0^2 \int_{\frac{x^2}{2}}^{4-x} xy dy dx$. 8
- Q.3**
- a) Evaluate $\iiint x^2 yz dx dy dz$ throughout the volume bounded by the planes $x = 0, y = 0, z = 0$ and $\frac{x}{a} + \frac{y}{b} + \frac{z}{c} = 1$. 6
 - b) Find the mass of lamina of a cardioid $r = a(1 + \cos \theta)$. If the density at any point varies as the square of its distance from its axis of symmetry. 6
 - c) Solve $(3x + 2)^2 \frac{d^2 y}{dx^2} + 5(3x + 2) \frac{dy}{dx} - 3y = x^2 + x + 1$. 8

- Q.4 a) Find by double integration the area common to the circles $r = 2\cos\theta$ and $r = 2\sin\theta$. 6
- b) Solve $\sin 2x \frac{dy}{dx} = y + \tan x$. 6
- c) Solve $\frac{dy}{dx} = 3x + y^2$ with initial conditions $y_0 = 1$, $x_0 = 0$ at $x=0.2$ in steps of $h=0.1$ by Runge Kutta method of fourth order. 8
- Q.5 a) Evaluate $\int_0^1 x^5 \sin^{-1} x dx$ and find the value of $\beta\left(\frac{7}{2}, \frac{1}{2}\right)$. 6
- b) The differential equation of a moving body opposed by a force per unit mass of value cx and resistance per unit mass of value bv^2 where x and v are the displacement and velocity of the particle at that time is given by $v \frac{dv}{dx} = -cx - bv^2$. Find the velocity of the particle in terms of x , if it starts from the rest. 6
- c) Evaluate $\int_0^6 \frac{dx}{1+4x}$ by using i) Trapezoidal ii) Simpsons (1/3)rd and iii) Simpsons (3/8)th rule. 8
- Q.6 a) Find the volume of the region that lies under the paraboloid $z = x^2 + y^2$ and above the triangle enclosed by the lines $y = x$, $x = 0$ and $x + y = 2$ in the xy plane. 6
- b) Change to polar coordinates and evaluate $\iint y^2 dx dy$ Over the area outside $x^2 + y^2 - ax = 0$ and inside $x^2 + y^2 - 2ax = 0$. 6
- c) Solve by method of variation of parameters $\frac{d^2y}{dx^2} + y = \frac{1}{1+\sin x}$. 8

(2 Hours)

[Total Marks : 60]

N.B.: (1) Question No. 1 is compulsory

(2) Attempt any three questions from remaining Question No's 2 to 6

(3) Assume suitable data wherever required.

(4) Figures to the right indicate marks.

1. Attempt any Five

(15M)

- Explain the formation of colors in thin film when it is exposed to white light.
- Write the formula for dispersive power of the grating. Explain how it can be increased.
- A bare core optical fiber with no cladding is kept in air medium and has fractional index difference of 1.2 %. Calculate acceptance angle of the fibre.
- Differentiate between photography and holography.
- Using cylindrical coordinate system, calculate volume of the cylinder of radius r and height h .
- An electron is accelerated through a potential difference of 18 kV in a cathode ray tube. Calculate kinetic energy and speed of the electron.
- Explain top down and bottom up approaches to prepare nanomaterials.

2.

- What is anti-reflection coating? State the conditions for refractive index and thickness of the film in order to act as anti-reflection coating.

White light is sent vertically downward onto a horizontal thin film that is sandwiched between the materials. The indices of the refraction are 1.8 for top material, 1.65 for thin film and 1.50 for the bottom material. The film thickness is 5×10^{-7} m. Which are the visible wavelengths (400 -700 nm) those results in fully constructive interference at an observer above the film? (8M)

- Give the advantageous of optical fiber cables on conventional electrical cables. Calculate core radius required for an optical fibre to act as a single mode fibre if its core refractive index is 1.46 and cladding refractive index is 1.455 and operating wavelength is 1300 nm. (7M)

3.

- Explain Fraunhofer's double slit diffraction experiment and obtain expression for resultant intensity of light on the screen and derive the formula for missing orders in the double slit diffraction pattern. (8 M)

- With energy level diagram explain the construction and working of He-Ne Laser. (7M)

4.

- Calculate divergence of the vector field $\vec{F} = x^2y\vec{i} - (z^3 - 3x)\vec{j} + 4y^2\vec{k}$. (5 M)

- Draw the block diagram of cathode ray oscilloscope (CRO) and explain the importance of time base circuit. (5 M)

- Interference fringes are produced by monochromatic light falling normally on a wedge shaped film of refractive index 1.4. The angle of wedge is 20 seconds of an arc and the distance between successive bright fringes is 0.25 cm. Calculate wavelength of the light used. (5 M)

- 5.
- Write Maxwell's equations in differential form and give their physical significance. (5M)
 - The ground state and excited state of the laser is separated by 1.8 eV. Calculate the ratio of number of atoms in the excited state to the ground state and wavelength of the radiation emitted at 27°C (5 M)
 - Explain construction and working of atomic force microscope (AFM). (5 M)
- 6.
- Explain sputtering method for synthesis of nano materials. (5 M)
 - Explain experimental arrangement of Newton's rings experiment and show that diameters of dark rings are proportional to square root of natural numbers. (5 M)
 - An electron enters in a uniform magnetic field $B = 0.23 \times 10^{-2} \text{ wb/m}^2$ at 45° angle to B. Determine radius and pitch of the helical path. Assume electron speed to be $3 \times 10^7 \text{ m/sec}$. (5 M)

[Time: 2 Hours]

[Total Marks:60]

Please check whether you have got the right question paper.

- N.B:
1. Question.No.1 is compulsory.
 2. Attempt any three questions out of remaining five
 3. Figure to the right indicates full marks.
 4. Atomic weights C=12, S=32, N=14, H=1, O=16, Cl=35.5.

- Answer any five from the following 15
- Define octane number and write its significance.
 - What is the difference between anodic and cathodic coatings?
 - Calculate higher calorific value of a coal sample containing C=85%, H=1%, N=1.5%, O=5%, S=0.4% and remaining being ash.
 - Write the composition, properties and uses of commercial brass.
 - Explain the principle "Inherently Safer Chemistry of Accident Prevention" in green chemistry.
 - Write the classification of composite materials.
 - What are functions of pigments in paints?
- 2
- Define corrosion. Explain the mechanism of wet corrosion with respect to neutral and alkaline media. 6
 - i) 1.4 gm of coal sample on combustion gave 0.3 gm of barium sulphate precipitate. Calculate the percentage of sulphur in the sample. 3
ii) What are the industrial applications of super critical CO₂? 2
 - What are large particle reinforced composite materials? Explain with the help of examples. 4
- 3
- What is cracking? Explain in detail fixed bed catalytic cracking. 6
 - i) What are shape memory alloys? What are their applications? 3
ii) How does the presence of humidity affect the rate of corrosion? 2
 - Calculate the percentage atom economy of the following reaction with respect to the product allyl chloride

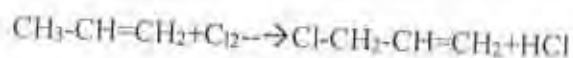

Allyl Chloride

- 4 (a) What is anodic protection method of corrosion control? Explain with the help of a neat diagram. 6
- (b)(i) What are the industrial applications of the products from natural materials? 3
- ii) What are the functions of matrix phase of composite materials? 2
- (c) Write a note on heat resisting steel. 4
- 5 (a) A sample of coal was found to contain C=90%, O=5%, H=1%, S=0.5% and remaining being nitrogen. Calculate weight and volume of air required for complete combustion of 1 kg of coal sample. (M.W. of air=28.949) 6
- (b)(i) "The noble metals do not undergo corrosion" Justify the statement. 3
- ii) What are the applications of fuel cell? 2
- (c) Explain with suitable equations, conventional and green synthesis of adipic acid. 4
- 6 (a) What is powder metallurgy? Explain powder injection moulding method with the help of a neat diagram. 6
- (b)(i) What are the characteristics of composite materials? 3
- ii) What are the characteristics of a paint film? 2
- (c) What is biodiesel? Write the advantages of biodiesel. 4

39b

7/6/19

(3 Hours)

[Total Marks: 60]

N. B. - 1. Attempt any four questions.

- 2. Use first angle method of projection, unless mentioned otherwise.
- 3. Write all answers on drawing sheets only & use both sides of the sheets.
- 4. Use your own judgment for any unspecified dimension.
- 5. Retain construction lines.
- 6. All dimensions are in mm.

Q.1.(a) One end of an inelastic string, 125mm long is attached to the circumference of a circular disc of 50 mm diameter. The free end of the string is wound around the disc, keeping the string always tight. Draw the locus of the free end and name the curve. (06)

Q.1.(b) For the object shown in figure draw the following views -
 (i) Front view in the direction of arrow X. (05)
 (ii) Top view. (04)

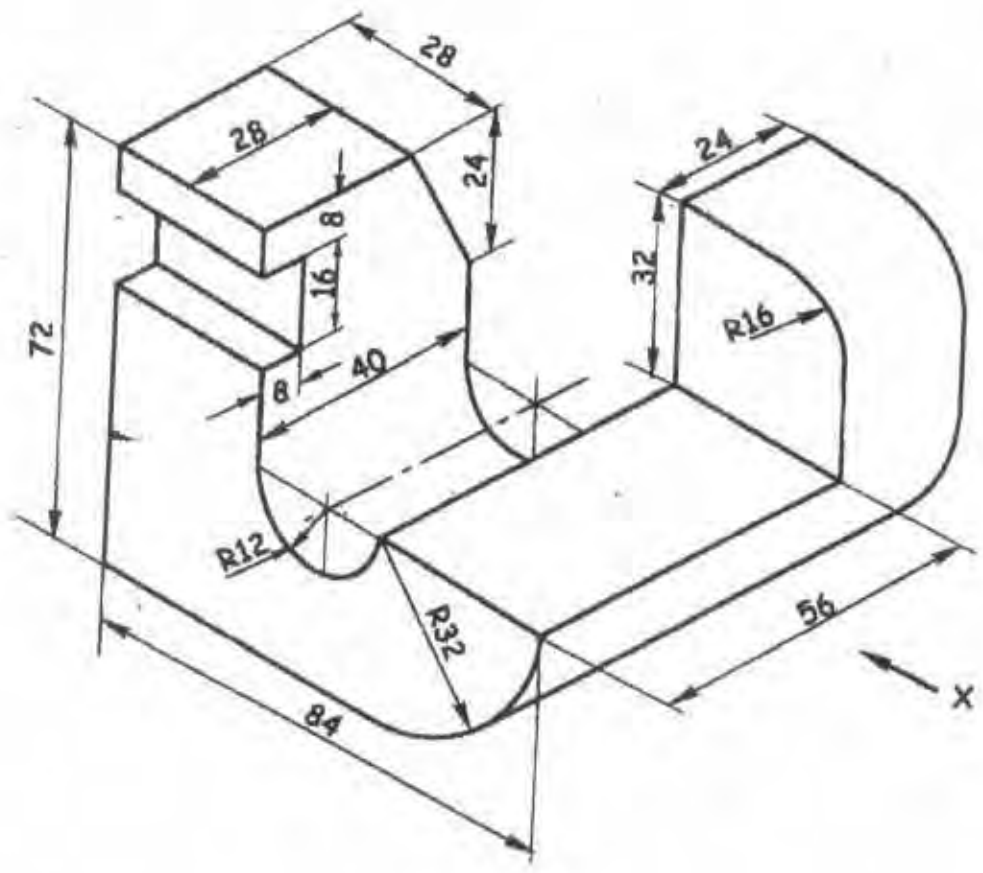

Q.2 For the object shown in figure draw the following views -

- (i) Sectional front view along section A-A
- (ii) Side view from left
- (iii) Top view
- (iv) Insert the major dimensions

(04)
(04)
(05)
(02)

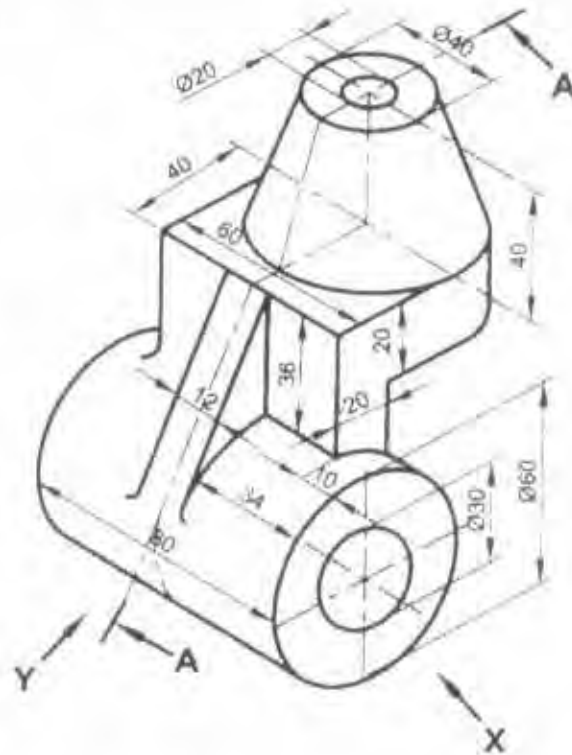

- Q.3 A pentagonal pyramid of 30 mm age of base and 60 mm axis height is lying on one of its triangular surfaces in the V.P. so that the axis is inclined at angle of 45° to the H.P. Draw its front view and top view. (15)
- Q.4 (a) A right circular cylinder diameter of base 50 mm and axis height 70 mm has one of the circumference point of base in the HP, such that its axis is inclined at 30° to the H.P. Draw its projections. (06)

Q.4 (b) Figure shows two views of an object. Draw its isometric view.

(09)

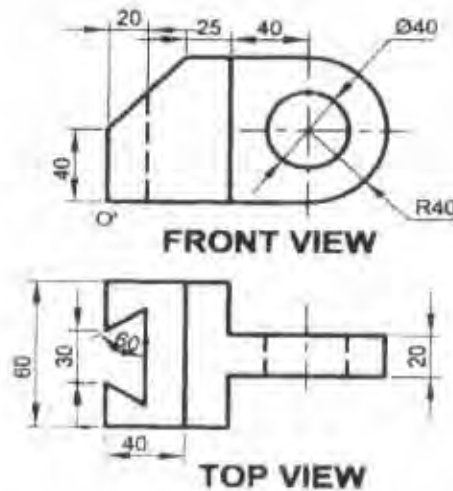

Q.5. A cone of base 70 mm diameter and axis 90 mm long is resting on its base on HP. It is cut by a section plane perpendicular to the VP and parallel to and 15 mm away from one of its end generators. Draw the sectional top view, front view & sectional side view. Also draw the true shape of the section. Also draw development of the lateral surface of the cone. (15)

Q.6 (a) The T.V. of line AB measures 60 mm and is inclined at 56° to the XY line. Point A is 10 mm above the H.P. and 20 mm in front of the V.P. Point B is 45 mm above H.P. and in front of the V.P. Draw the projection of line AB. (09)

Q.6 (b) Figure shows two views of an object. Draw its isometric view with 'O' as origin. (06)

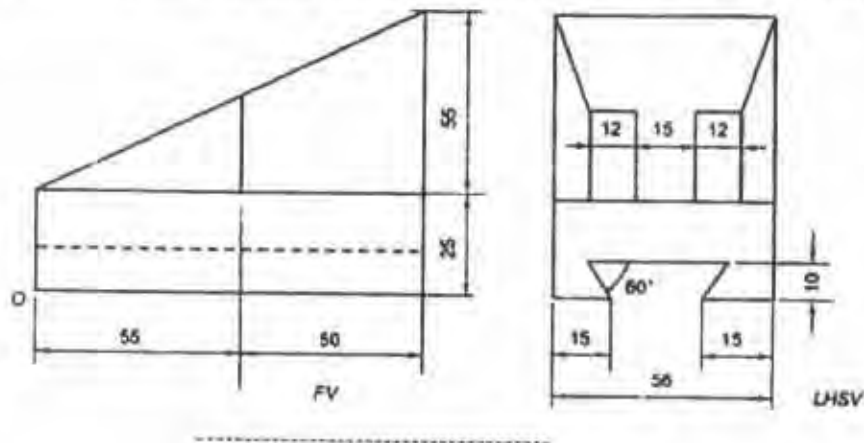

396

Time: 3 Hours

Total Marks: 80

N.B

- (1) Question no. 1 is compulsory.
- (2) Attempt any 3 from the remaining questions.
- (3) Assume suitable data if necessary.
- (4) Figures to right indicate full marks.

Q.1 a Attempt the Multiple Choice Questions

6

```
i) #include <stdio.h>
int main()
{
    int a=0;
    a=a++ + a++ - a++ + ++a;
    printf("%d\n", a);
    return 0;
}
```

The output of above program is

- (a) 2 (b) 0 (c) 3 (d) Error

ii) Which of the following operator can be used to access value at address stored in a pointer variable?

- (a) * (b) @ (c) & (d) &&

iii) In C Programming which of the operator have the highest precedence

- (a) Relational (b) Arithmetic (c) Bitwise (d) Logical

iv) Which of the following are themselves a collection of different data types?

- (a) string (b) 2D Arrays (c) structures (d) char

v) If x and b are the float variable what is the value of x when x=sizeof(b).

- (a) 2 (b) 3 (c) 4 (d) Null

vi) The default value of static storage class variable is

- (a) Zero (b) Garbage (c) One (d) None of above

b) Find the output of following

4

```
i) #include <stdio.h>
int main()
{
    int a=1;
    do{
        a++;
        ++a;
    }while(a++>25);

    printf("%d\n",a);

    return 0;
}
```

```

ii) #include <stdio.h>
int main()
{
    int x;
    x = 10;
    if(x > 10)
        x = 10;
    else if(x >= 0)
        x += 00;
    else if(x)
        x += 10;
    else
        x -= 10;

    printf("%d\n",x);
    return 0;
}

```

- c) Convert the following 6
- i) 153 from base 10 to Hexadecimal
 - ii) 1100 1101 1001 1011 from base 2 to decimal
 - iii) 143 from base 8 to decimal

- d) Differentiate between Structure and Union 4

- Q.2 a) What is recursion? Write a program using recursion to calculate the value of $Z=X^Y$. 8
- b) Write a function to reverse a 3 digit number 6
- c) Write a program to display following pattern 6

```

    0
   0 1
  0 1 0
 0 1 0 1
0 1 0 1 0

```

- Q.3 a) Write a program to find the frequency of digits in a set of numbers and remove duplicates from an array. For ex. array $A=\{1,2,3,4,2,5,2\}$ frequency of 2 is 3 and resultant array is $A=\{1,2,3,4,5\}$. 10
- b) Explain the concept of nested structure? Declare a structure to enter employee information like name, id, salary, date of joining. Use nested structure to get the address of an employee. Write a program to read 10 records and display them. 10

- Q.4 a) Explain strcat() & strcpy() with example. Also write a program to check whether entered string is palindrome or not without using inbuilt string functions. 10
- b) Differentiate between call by value and call by reference. Write a program to calculate Factorial of a number using call by reference. 10

- Q.5 a) What is file? Explain the functions available for Reading & Writing data of files? 10
Write a program to take student information from user and store it in file. 10
- b) Write a program to calculate sum of diagonal elements of a matrix.
For ex.
1 2 3
5 9 8
1 4 7
Calculate the sum of diagonal elements=3+9+1=13
- Q.6 a) Explain storage classes with example. 10
- b) Write a program to find greatest number among three entered number using ternary operator 4
- c) Write a program to calculate the sum of series 6
 $x - x/2! + x/3! - x/4! + \dots + x/n!$
-

Duration: 2 Hours

Total Marks: 40

N.B.:

1. Question No. 1 is compulsory.
2. Attempt any **three** from the remaining **five** questions.
3. Figures to the right indicate marks.
4. Answers to all sub questions should be attempted and grouped together.

1. A) Elucidate non- verbal communication with any five types, which should be applied while attending an interview. **4M**
- B) Identify the barriers from any **two** situations and briefly state how to overcome them: **6M**
 - i) The sales target could not be achieved despite marketing the product well in advance.
 - ii) A presentation session was not appreciated in spite of thorough preparation by the speaker.
 - iii) A friend of yours is unable to keep his appointment with you. Neither is there any phone call later apologizing. You had set aside time from a very busy day and had to cancel some other work. You are upset and conclude that your friend is indifferent to commitment.
2. A) Give reasons why it is essential for engineering students to study communication skills. **2M**
- B) For the following communication situations identify the Sender, Message, Medium, Channel, Receiver and Feedback. **6M**
 - i) A project presentation
 - ii) An advertisement campaign
- C) Draw the lay-out of Complete block format **2M**
3. A) Explain any 4 principles of business correspondence (4C's) **3M**
- B) Change the sentences into 'You- attitude' **2M**
 - i) We regret that the goods did not reach the buyers on time
 - ii) We cannot approve your refund request until we receive complete information with the required documents.
- C) As the Sales Director of Fitness Plus Centre, Mumbai, draft a sales letter to Business Professionals describing them your 3 Wellness Packages: 1. The 3- day Fitness Weekend
2. The 7-day Total Fitness Program 3. The Individualized Corporate Well-Being Program. **5M**
4. A) Choose a useful computer program and write **five** instructions on how to use it. **5M**
- B) One word substitutes: **5M**
 - i) A reference work providing summaries of knowledge from either all branches or from a particular discipline. (E)
 - ii) The study of the origin and history of words (E)
 - iii) Study of the role of Time in communication (C)
 - iv) One who does election analysis (P)
 - v) Name adopted by an author in his writings (P)

2. A) Write short notes on any **four**:
i) Grapevine ii) Listening iii) Feedback iv) Proxemics v) Appearance **8M**
- B) Match the following: **2M**
- | A | B |
|---|----------|
| Specialized Vocabulary | Warning |
| Rapid reading technique | Note |
| Instructions to avoid an injury | Jargon |
| Information for performing the task correctly | Scanning |

3. A) Re-arrange the following letter making the necessary corrections in form, punctuation, language and style: **3M**
- Hewlett-Packard Ltd, India Chandiwala Estate, Maa Anandmayi Marg, Kalkaji, N. Delhi 110019**
- Your Ref.
Our Ref.
Date:
Dear Mr. Singh
- Thank you very much for your enquiry which is received today. I am enclosing our catalogue and price list for the equipment, you said you are interested in. We would welcome any further enquiries you have and look forward to hearing from you.
- Yours sincerely,
D. Sampson
Sales Manager
Encl: Catalogue and price list
- To
Mr. Rakesh Singh
Digital Equipment
92 Industrial Suburb,
Yeshwantpur, Bangalore 560022.

Read the passage and answer the questions:

In communication the 'audience' is the person or group of people whom you expect to read your information. Even though writers do not know exactly who will read their documents, they can usually define an intended audience as technical, semi technical or non- technical.

The **technical audience** includes practitioners in your field: those with technical experience and training such as technicians and engineers. Technical audience understands fundamental concepts and jargons without definitions or background information. Readers expect the writer to use technical language efficiently and appropriately.

The **semi technical audience** has some technical training or work in the industry, but not directly in the field, those working in related departments or those with training in related technical areas. This might even include Personnel in marketing, finance or administration of a technical company. The semi technical audience needs some explanation of concepts, abbreviations and jargons. Writers use technical terms only if they are common in the company or industry. For this audience you might provide an orientation to the subject and explain or interpret the terms and information.

The last type of audience is **non- technical audience** includes general public, an unknown audience or any combination of technical, non- technical and semi technical audience, including customers, clients and patients. It might also include upper management – a group which is uninvolved with technical activities, but which must have an active role in decision making for the company. This audience expects a clear organization that progresses from the background to the new information with examples or illustrations to explain points that may be confusing.

For this audience writers provide the most comprehensive treatment of the subject, such as common terminology, simple language free of jargon and technical data, a full background and orientation to the subject along with a complete discussion of the main points. To simplify difficult concepts writers often compare technical processes to more familiar ones through analogies and metaphors.

1. Define 'audience' as it applies to technical communication **1M**
2. How does the author adapt himself/herself to technical audience? **2M**
3. What type of people constitute non-technical audience? **2M**
4. Why do the writers need to explain or interpret the terms for a semi technical audience? **2M**
