



AIKTC/KRRC/SoET/ACKN/QUES/2018-19/

Date: _____

School: SoET-CBCS

Branch: COMP. ENGG.

SEM: III

To,
 Exam Controller,
 AIKTC, New Panvel.

Dear Sir/Madam,

Received with thanks the following [✓]Semester/[✓]Unit Test-I/[✓]Unit Test-II (Reg./ATKT) question papers from your exam cell:

Sr. No.	Subject Name	Subject Code	Format		No. of Copies
			SC	HC	
1	Applied Mathematics- III	CSC301		✓	02
2	Digital Logic Design & Analysis	CSC302		✓	02
3	Discrete Structures	CSC303		✓	02
4	Electronic Circuits and Communication Fundamentals	CSC304		✓	02
5	Data Structures	CSC305		✓	02

Note: SC – Softcopy, HC - Hardcopy

(Shaheen Ansari)
 Librarian, AIKTC

37

8/5/19

Q. P. Code: 21237

Time: 3 Hours

Marks: 80

- Note: 1) Q.1 is COMPULSORY.
 2) Attempt ANY 3 questions from Q.2 to Q.6
 3) Use of scientific calculators allowed.
 4) Figures to right indicate marks.

- Q.1 a) Find the Laplace transform of $t e^t \sin 2t \cos t$. (05)
 b) Find the inverse Laplace transform of $\frac{s+2}{s^2(s+3)}$ (05)
 c) Determine whether the function $f(z) = x^2 - y^2 + 2ixy$ is analytic and if so find its derivative. (05)
 d) Find the Fourier series for $f(x) = e^{-|x|}$ in the interval $(-\pi, \pi)$. (05)

- Q.2 a) Evaluate $\int_0^{\infty} \frac{e^{-t} - t \cos t}{t e^{4t}} dt$ (06)
 b) Find the Z-Transform of $f(k) = \begin{cases} 3^k, & k < 0 \\ 2^k, & k \geq 0 \end{cases}$ (06)
 c) Show that the function $u = 2x(1-y)$ is a harmonic function. Find its harmonic conjugate and corresponding analytic function. (08)

- Q.3 a) Find the equation of the line of regression of y on x for the following data (06)

X	10	12	13	16	17	20	25
y	19	22	24	27	29	33	37

- b) Find the bilinear transformation which maps $z = 2, 1, 0$ onto $w = 1, 0, i$. (06)
 c) Obtain the expansion of $f(x) = x(\pi - x)$, $0 < x < \pi$ as a half range cosine series.

Hence show that $\sum_{n=1}^{\infty} \frac{(-1)^{n+1}}{n^2} = \frac{\pi^2}{12}$. (08)

- Q.4 a) Find the inverse Laplace Transform by using convolution theorem $\frac{1}{(s^2+4)(s^2+9)}$ (06)

- b) Calculate the coefficient of correlation between Price and Demand. (06)

Price : 2, 3, 4, 7, 4.

Demand : 8, 7, 3, 1, 1.

c) Find the inverse Z-transform for the following : (08)

i) $\frac{z}{z-5}$, $|z| < 5$ ii) $\frac{1}{(z-1)^2}$, $|z| > 1$

Q.5 a) Find the Laplace transform of $e^{-t} \sin t H(t - \pi)$ (06)

b) Show that the set of functions $\{ \sin x, \sin 3x, \sin 5x, \dots \}$ is orthogonal over $[0, \pi/2]$. Hence construct orthonormal set of functions. (06)

c) Solve using Laplace transform $\frac{d^2y}{dt^2} - 2\frac{dy}{dt} + y = 3t e^{-t}$, given $y(0) = 4$ and $y'(0) = 2$. (08)

Q.6 a) Find the complex form of Fourier series for $f(x) = 3x$ in $(0, 2\pi)$. (06)

b) If $f(z)$ is an analytic function with constant modulus then, prove that $f(z)$ is constant. (06)

c) Fit a curve of the form $y = ax^b$ to the following data. (08)

x	1	2	3	4
y	2.5	8	19	50

(Time: 3 Hours)

(Marks:80)

N.B. (1) Question No. 1 is compulsory

(2) Assume suitable data if necessary

(3) Attempt any three questions from remaining questions

1 Attempt any 5

- (a) Convert $(451.43)_{10}$ into octal, binary and hexadecimal and base 7. (4)
- (b) Subtract using 1's and 2's complement method $(73)_{10} - (49)_{10}$ (4)
- (c) Perform $(52)_{10} - (68)_{10}$ in BCD using 9's complement. (4)
- (d) State De Morgan's theorem. Prove OR-AND configuration is equivalent to NOR-NOR configuration. (4)
- (e) Encode the data bits 111010001 using Hamming code. (4)
- (f) Explain SOP and POS and solve the following using K-Map
 $F(A,B,C,D) = \sum m(1,3,5,6,7,10,11) + d(2,4)$ (4)
- (g) Explain lockout condition. How can it be avoided (4)

2 (a) Reduce equation using Quine McCluskey method and realize circuit using basic gates. (10)

$$F(A,B,C,D) = \sum m(1,5,6,12,13,14) + d(2,4)$$

(b) Design 4-bit BCD subtractor using IC 7483. (10)

3 (a) Implement the following using only one 8:1 Mux. (5)

$$F(A,B,C,D) = \sum m(0,2,4,6,8,10,12,14)$$

(b) Design a Full Subtractor using only NAND gates. (5)

(c) Design a logic circuit to convert 4-bit gray code to its corresponding BCD code. (10)

4(a) Compare different logic families with respect to fan in, fan out, speed, Propagation delay and power dissipation. (5)

(b) Implement 3 bit binary to gray code converter using Decoder. (5)

(c) Explain 4 bit bidirectional shift register. (10)

5 (a) Design mod 13 synchronous counter using T flipflop (10)

(b) Convert SR flipflop to JK flipflop and D flipflop. (10)

6 Write short note on (any four):- (20)

- (a) ALU
- (b) 3 bit Up/Down Asynchronous Counter
- (c) Octal to Binary Encoder
- (d) 4-bit Universal shift register
- (e) VHDL

12

20/3/19

QP CODE : 40415

(3 hrs)

Max. Marks: 80

- 1) Question no.1 is compulsory.
- 2) Solve any THREE questions out of remaining FIVE questions.
- 3) All questions carry equal marks as indicated by figures to the right.
- 4) Assume appropriate data whenever required. State all assumptions clearly.

- Q.1 a) Prove using Mathematical Induction (05M)
 $2+5+8+\dots+(3n-1)=n(3n+1)/2$
- b) Find the generating function for the following finite sequences (05M)
 i) 1,2,3,4,... ii) 2,2,2,2,2
- c) Let $A = \{1, 4, 7, 13\}$ and $R = \{(1,4), (4,7), (7,4), (1,13)\}$
 Find Transitive Closure using Warshall's Algorithm (05M)
- d) Let $f: \mathbb{R} \rightarrow \mathbb{R}$, where $f(x) = 2x - 1$ and $f^{-1}(x) = (x+1)/2$ (05M)
 Find $(f \circ f^{-1})(x)$

- Q.2 a) Define Lattice. Check if the following diagram is a lattice or not. (04M)



- b) Prove that set $G = \{1,2,3,4,5,6\}$ is a finite abelian group of order 6 with respect to multiplication module 7 (08 M)
- c) A travel company surveyed it's travelers, to learn how much of their travel is taken with an Airplane, a Train or a Car. The following data is known; make a complete Venn Diagram with all the data. The number of people who flew was 1307. The number of people who both flew and used a train was 602. The people who used all three were 398 in number. Those who flew but didn't drive came to a total of 599. Those who drove but did not use a train totaled 1097. There were 610 people who used both trains and cars. The number of people who used either a car or a train or both was 2050. Lastly, 421 people used none of these Find out how many people drove but used neither a train nor an airplane, and also, how many people were in the entire survey. (08 M)

- Q.3 a) Prove $\neg(p \vee (\neg p \wedge q))$ and $\neg p \wedge \neg q$ are logically equivalent by developing a series of logical equivalences. (04 M)

- b) Consider the (3,5) group encoding function defined by (08 M)
- | | |
|----------------|----------------|
| $e(000)=00000$ | $e(001)=00110$ |
| $e(010)=01001$ | $e(011)=01111$ |
| $e(100)=10011$ | $e(101)=10101$ |
| $e(110)=11010$ | $e(111)=11000$ |

Decode the following words relative to a maximum likelihood decoding function.

- i) 11001 ii) 01010 iii) 00111
- c) Mention all the elements of set D_{16} also specify R on D_{16} as aRb if $a | b$. Mention Domain and Range of R. Explain if the relation is Equivalence Relation or a Partially Ordered Relation. If it is a Partially Ordered Relation, draw its Hasse Diagram. (08 M)

- Q.4 a) Explain Extended pigeonhole Principle. How many friends must you have to guarantee that at least five of them will have birthdays in the same month. (04 M)
- b) Define Euler Path and Hamiltonian Path.
- i) Determine Euler Cycle and path in graph shown in (a)
- ii) Determine Hamiltonian Cycle and path in graph shown in (b)

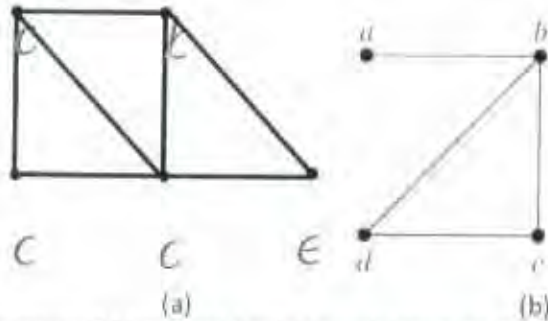

- c) In a group of 6 boys and 4 girls, four children are to be selected. In how many different ways can they be selected such that at least one boy should be there? (08 M)

- Q.5 a) Let G be a group. Prove that the identity element e is unique. (04M)
- b) A pack contains 4 blue, 2 red and 3 black pens. If 2 pens are drawn at random from the pack, NOT replaced and then another pen is drawn. What is the probability of drawing 2 blue pens and 1 black pen? (08M)
- c) Let A be a set of integers, let R be a relation on $A \times A$ defined by $(a,b) R (c,d)$ if and only if $a+d=b+c$. Prove that R is an equivalence Relation. (08M)

- Q.6 a) Define reflexive closure and symmetric closure of a relation. Also find reflexive and symmetric closure of R . (04 M)

$$A = \{1, 2, 3, 4\}$$

$$R = \{(1, 1), (1, 2), (1, 4), (2, 4), (3, 1), (3, 2), (4, 2), (4, 3), (4, 4)\}$$

- b) Let $H =$

$$\begin{pmatrix} 1 & 0 & 0 \\ 0 & 1 & 1 \\ 1 & 1 & 1 \\ 1 & 0 & 0 \\ 0 & 1 & 0 \\ 0 & 0 & 1 \end{pmatrix}$$

- Be a parity check matrix. Determine the group code $e_n, B^d \rightarrow B^6$ (08M)
- c) Determine if following graphs G_1 and G_2 are isomorphic or not. (08M)

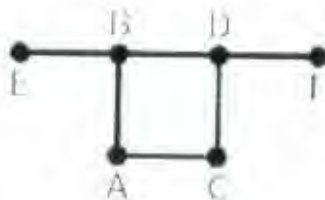

G_1

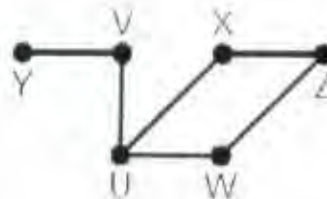

G_2



(3 Hours)

[Total Marks : 80]

- N.B. : 1. Question **ONE** is **Compulsory**.
 2. Solve any **THREE** out of remaining.
 3. **Draw** neat and **clean** Diagrams.
 4. Assume suitable **data** if required

Q.1. Attempt the following

- A. Explain with diagram Input and output characteristic of Common base configuration 5
- B. List the ideal Characteristic of op-amp 5
- C. Calculate the percent power saving an SSB signal if the AM wave is modulated to a depth of (a) 100 % and (b) 50% 5
- D. Define the term Information theory. Give definitions for Information Rate and Entropy 5

Q.2. A. For the circuit shown in Figure below calculate V_{CB, I_E} and I_B if $\beta=100$ 10

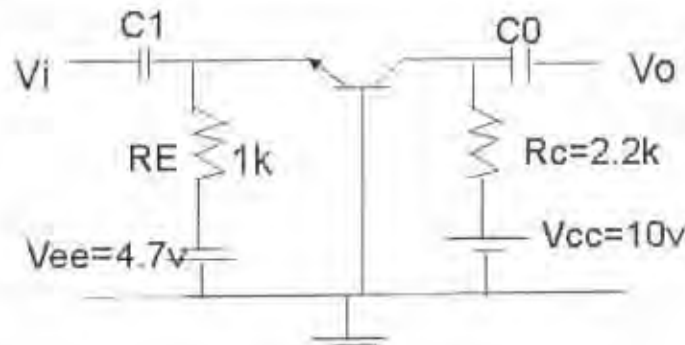

B. Explain how op-amp can be used as a differentiator. 10

- Q.3. A. What do you mean by Zero Crossing detector? Explain with diagram 5
 B. Write Short note on generation of FM by Armstrong method. 5
 C. Use op-amp IC741 to realize the expression $V_0=5V_1+2V_2-3V_3$ 5
 D. What is a Nyquist criteria? What is its significance 5

- Q.4. A. Explain Delta Modulation with neat diagram and waveforms after each block. 10
 B. An AM signal appears across a 50Ω load and has the following equation $v(t)=12(1+\sin 12.566 \times 10^3 t)\sin 18.85 \times 10^6 t$ volts 10
 1. Sketch the envelope of this signal in time domain
 2. Calculate modulation index, sideband frequencies, total power and bandwidth

- Q.5. A. Compare PAM, PWM and PPM pulse modulation techniques 10
 B. Explain the generation of DSBSC using Balance modulator 10

- Q.6. A. What do you mean by multiplexing? Explain TDM 10
 B. List down various parameters of op-amp with their practical values for IC741, Explain common mode gain and differential mode gain. 10

21

Paper / Subject Code: 50905 / Data Structures

Time: 3 Hours

Marks: 80

- N.B: (1) Question No.1 is compulsory
(2) Attempt any three questions of the remaining five questions.
(3) Figures to the right indicate full marks
(4) Make suitable assumptions wherever necessary with proper justifications

- Q.1 (a) Explain Linear and Non-Linear data structures. (5)
(b) Explain Priority Queue with example. (5)
(c) Write a program in 'C' to implement Quick sort. (10)
- Q.2 (a) Write a program to implement Circular Linked List. Provide the following operations: (10)
(i) Insert a node .
(ii) Delete a node
(iv) Display the list
(b) Explain Threaded Binary tree in detail (10)
- Q.3 (a) Explain Huffman Encoding with suitable example (10)
(b) Write a program in 'C' to check for balanced parenthesis in an expression using stack (10)
- Q.4 (a) Write a program in 'C' to implement Queue using array. (10)
(b) Explain different cases for deletion of a node in binary search tree. Write function for each case (10)
- Q.5 (a) Write a program in 'C' to implement Stack using Linked-List .Perform the following operations: (10)
(i) Push
(ii) Pop
(iii) Peek
(iii) Display the stack contents
(b) Explain Depth First search (DFS) Traversal with an example. Write the recursive function for DFS (10)
- Q.6: Write Short notes on (any two) (20)
(a) Application of Linked-List -Polynomial addition
(b) Collision Handling techniques
(c) Expression Tree
(d) Topological Sorting
