

A PROJECT REPORT
ON
“DESIGN AND FABRICATION OF ARDUINO BASED
FARM-BOT FOR PRECISION FARMING’

Submitted to
UNIVERSITY OF MUMBAI

In Partial Fulfilment of the Requirement for the Award of

BACHELOR’S DEGREE IN
MECHANICAL ENGINEERING

BY

ANSARI ASHAR MOHD. IRSHAD	16DME122
BHIKAN UMER SALIM	16DME133
CHOUGHULE OMKAR PREETAM	16DME135
KADAM ABHIJIT BALASAHEB	16DME140

UNDER THE GUIDANCE OF
PROF. MOMIN NAFE



DEPARTMENT OF MECHANICAL ENGINEERING
Anjuman-I-Islam's Kalsekar Technical Campus
SCHOOL OF ENGINEERING & TECHNOLOGY

Plot No. 2 3, Sector - 16, Near Thana Naka,
Khandagaon, New Panvel - 410206

2018-2019

AFFILIATED TO
UNIVERSITY OF MUMBAI

**A PROJECT REPORT
ON**

**“DESIGN AND FABRICATION OF ARDUINO BASED FARM-BOT
FOR PRECISION FARMING”**

**Submitted to
UNIVERSITY OF MUMBAI**

In Partial Fulfilment of the Requirement for the Award of

**BACHELOR’S DEGREE IN
MECHANICAL ENGINEERING**

BY

ANSARI ASHAR MOHD. IRSHAD	16DME122
BHIKAN UMER SALIM	16DME133
CHOUGHULE OMKAR PREETAM	16DME135
KADAM ABHIJIT BALASAHEB	16DME140

**UNDER THE GUIDANCE OF
PROF. MOMIN NAFE**



**DEPARTMENT OF MECHANICAL ENGINEERING
Anjuman-I-Islam's Kalsekar Technical Campus
SCHOOL OF ENGINEERING & TECHNOLOGY
Plot No. 2 3, Sector - 16, Near Thana Naka,**

Khandagaon, New Panvel - 410206

2018-2019

AFFILIATED TO



UNIVERSITY OF MUMBAI

Anjuman-i-Islam's Kalsekar Technical Campus

Department of Mechanical Engineering
SCHOOL OF ENGINEERING & TECHNOLOGY
Plot No. 2 and 3, Sector - 16, Near Thana Naka,
Khandagaon, New Panvel - 410206



CERTIFICATE

This is certify that the project entitled

“DESIGN AND FABRICATION OF ARDUINO BASED FARM-BOT FOR PRECISION FARMING“

submitted by

ANSARI ASHAR MOHD. IRSHAD	16DME122
BHIKAN UMER SALIM	16DME133
CHOUGHULE OMKAR PREETAM	16DME135
KADAM ABHIJIT BALASAHEB	16DME140

is a record of bonafide work carried out by them, in the partial fulfilment of the requirement for the award of Degree of Bachelor of Engineering (Mechanical Engineering) at *Anjuman-I-Islam's Kalsekar Technical Campus, Navi Mumbai* under the University of MUMBAI. This work is done during year 2018-2019, under our guidance.

Date: / /

(Prof. MOMIN NAFE)
Project Supervisor

(Prof. RIZWAN SHAIKH)
Project Coordinator

(Prof. ZAKIR ANSARI)
HOD, Mechanical Department

DR. ABDUL RAZAK HONNUTAGI
Director

External Examiner

Acknowledgements

I would like to take the opportunity to express my sincere thanks to my guide **Prof. Momin Nafe**, Assistant Professor, Department of Mechanical Engineering, AIKTC, School of Engineering, Panvel for his invaluable support and guidance throughout my project research work. Without his kind guidance & support this was not possible.

I am grateful to him for his timely feedback which helped me track and schedule the process effectively. His time, ideas and encouragement that he gave is help me to complete my project efficiently.

We would like to express deepest appreciation towards **DR. ABDUL RAZAK HONNUTAGI**, Director, AIKTC, Navi Mumbai, **Prof. ZAKIR ANSARI**, Head of Department of Mechanical Engineering and **Prof. RIZWAN SHAIKH**, Project Coordinator whose invaluable guidance supported us in completing this project.

At last we must express our sincere heartfelt gratitude to all the staff members of Mechanical Engineering Department who helped me directly or indirectly during this course of work.

ANSARI ASHAR MOHD. IRSHAD
BHIKAN UMER SALIM
CHOUGHULE OMKAR PREETAM
KADAM ABHIJIT BALASAHEB

Project I Approval for Bachelor of Engineering

This project entitled ***DESIGN AND FABRICATION OF ARDUINO BASED FARM-BOT FOR PRECISION FARMING*** by ***ANSARI ASHAR MOHD. IRSHAD , BHIKAN UMER SALIM , CHOUGHULE OMKAR PREETAM , KADAM AB-HIJIT BALASAHEB*** is approved for the degree of ***Bachelor of Engineering in Department of Mechanical Engineering.***

Examiners

1.

2.

Supervisors

1.

2.

Chairman

.....

Declaration

I declare that this written submission represents my ideas in my own words and where others ideas or words have been included, I have adequately cited and referenced the original sources. I also declare that I have adhered to all principles of academic honesty and integrity and have not misrepresented or fabricated or falsified any idea/data/fact/source in my submission. I understand that any violation of the above will be cause for disciplinary action by the Institute and can also evoke penal action from the sources which have thus not been properly cited or from whom proper permission has not been taken when needed.

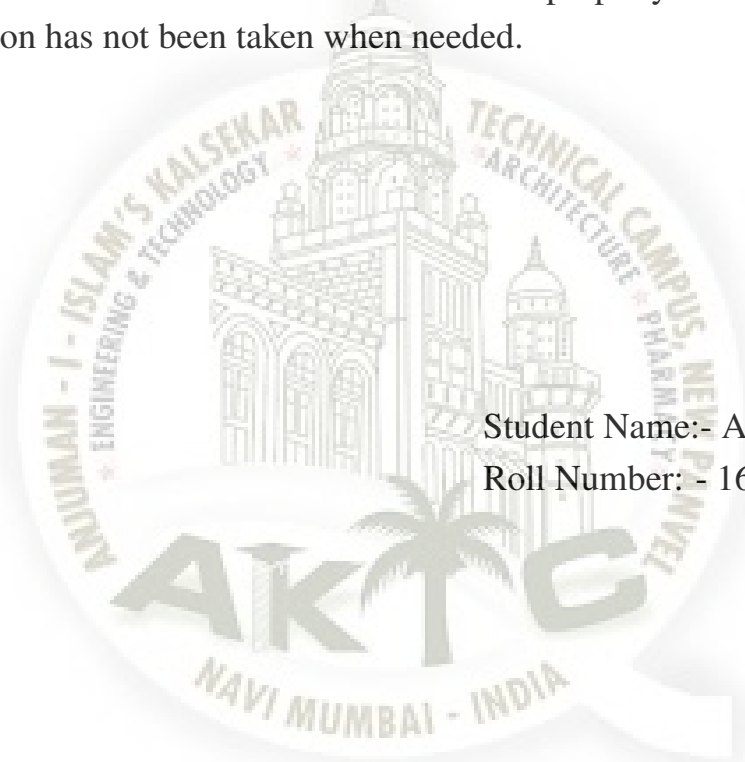

Student Name:- ANSARI ASHAR

Roll Number: - 16DME122

Declaration

I declare that this written submission represents my ideas in my own words and where others ideas or words have been included, I have adequately cited and referenced the original sources. I also declare that I have adhered to all principles of academic honesty and integrity and have not misrepresented or fabricated or falsified any idea/data/fact/source in my submission. I understand that any violation of the above will be cause for disciplinary action by the Institute and can also evoke penal action from the sources which have thus not been properly cited or from whom proper permission has not been taken when needed.

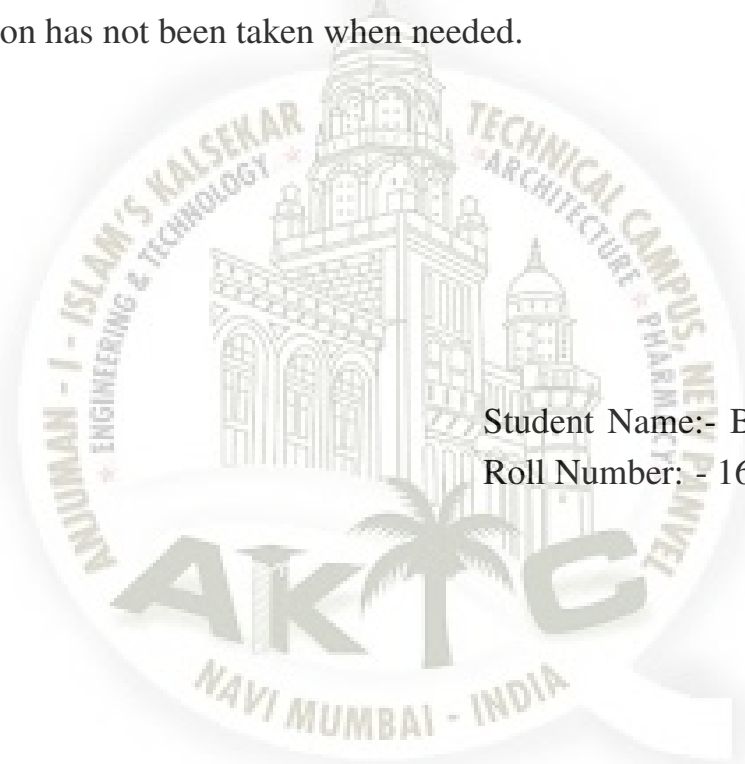

Student Name:- BHIKAN UMER

Roll Number: - 16DME133

Declaration

I declare that this written submission represents my ideas in my own words and where others ideas or words have been included, I have adequately cited and referenced the original sources. I also declare that I have adhered to all principles of academic honesty and integrity and have not misrepresented or fabricated or falsified any idea/data/fact/source in my submission. I understand that any violation of the above will be cause for disciplinary action by the Institute and can also evoke penal action from the sources which have thus not been properly cited or from whom proper permission has not been taken when needed.

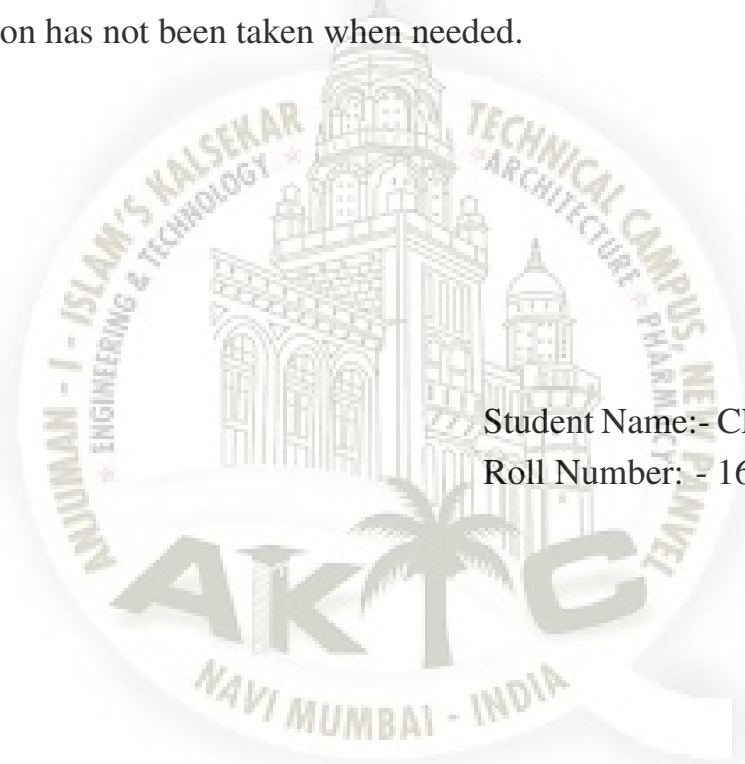

Student Name:- CHOUGHULE OMKAR

Roll Number: - 16DME135

Declaration

I declare that this written submission represents my ideas in my own words and where others ideas or words have been included, I have adequately cited and referenced the original sources. I also declare that I have adhered to all principles of academic honesty and integrity and have not misrepresented or fabricated or falsified any idea/data/fact/source in my submission. I understand that any violation of the above will be cause for disciplinary action by the Institute and can also evoke penal action from the sources which have thus not been properly cited or from whom proper permission has not been taken when needed.

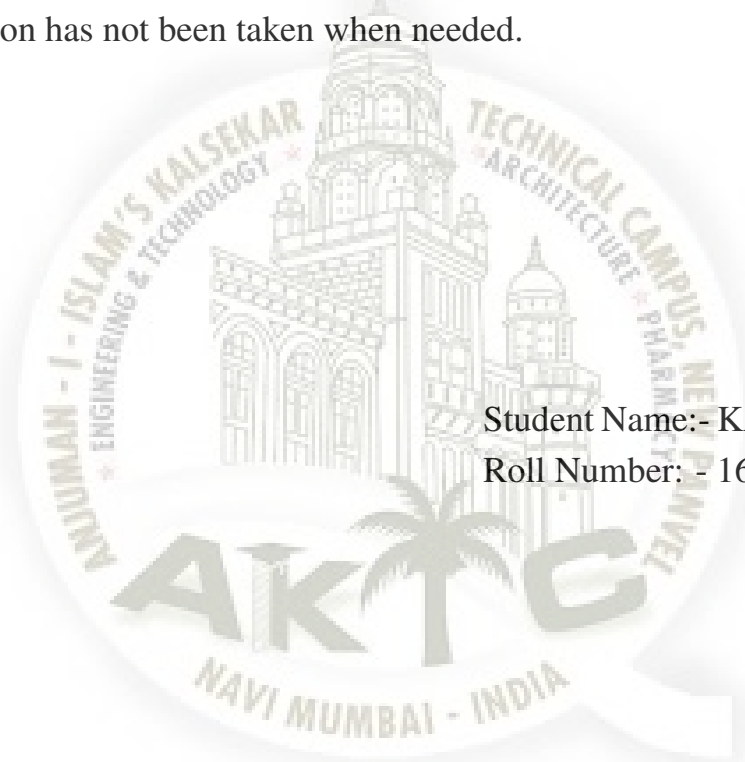

Student Name:- KADAM ABHIJIT

Roll Number: - 16DME140

ABSTRACT

Looking towards the current scenario of our food production system, one can say how broken it is. As a result we are destroying our health as well as our environment. For that we came up with a new paradigm of precision agriculture to reduce the environment impacts of farming by reducing water use, energy, transportation, petrochemicals and to grow our organic food by our self at our own place.

The end goal with Farmbot is to create a robot that will tend to a variety of plants in a garden, with minimal user interaction through a computer or mobile application. Each plant could be given specialized care according to their needs, and Farmbot could monitor the growth of each plant from seeding to harvesting time. Obviously this is a massive undertaking, so we honed the scope of our senior project down to take advantage of our expertise and to provide us with achievable goals.

Keywords: Precision Farming, Arduino Based Robot, Organic Foods

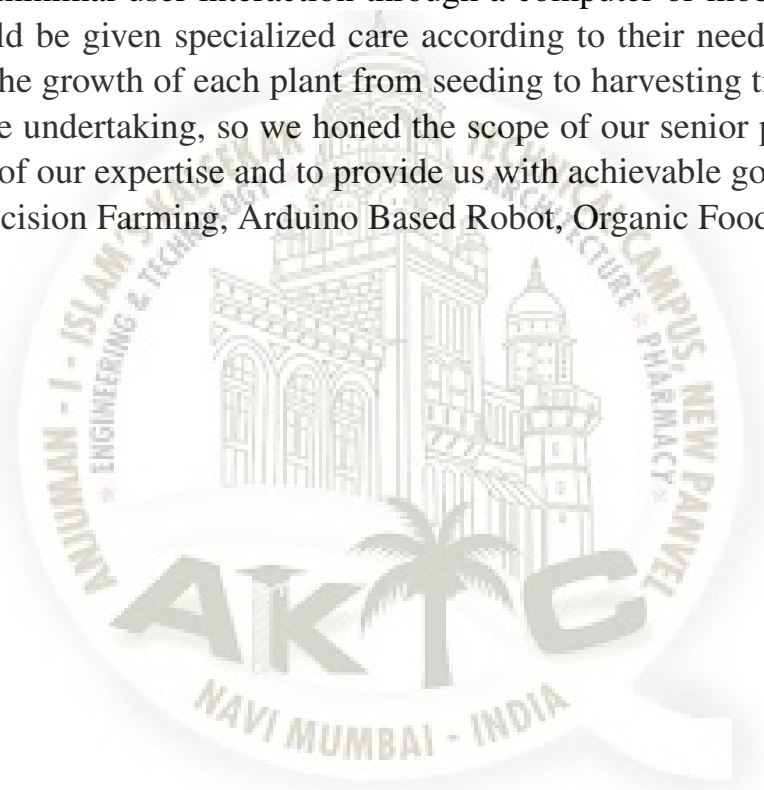

Contents

Acknowledgement	iii
Project I Approval for Bachelor of Engineering	iv
Declaration	v
Declaration	vi
Declaration	vii
Declaration	viii
Abstract	ix
Table of Contents	xii
1 Introduction	2
1.1 Purpose	3
1.2 Project Scope	3
1.3 Project Goals and Objectives	4
2 Literature Survey	5
2.1 Paper Title 1	5
2.1.1 ABSTRACT	5
2.1.2 INTRODUCTION	5
2.1.3 CONCLUSION	6
2.2 Paper Title 2	7
2.2.1 ABSTRACT	7
2.2.2 INTRODUCTION	7
2.2.3 CONCLUSION	8
2.3 Paper Title 3	8
2.3.1 ABSTRACT	8
2.3.2 INTRODUCTION	8
2.3.3 CONCLUSION	9
2.4 Paper Title 4	9
2.4.1 INTRODUCTION	9
2.4.2 CONCLUSION	10
2.5 Technical Review	10
2.5.1 Reasons to use this Technology	10

3	Project Planning	11
3.1	Members and Capabilities	11
3.2	Roles and Responsibilities	12
3.3	Assumptions and Constraints	12
3.4	Project Management Approach	12
3.5	Ground Rules for the Project	12
3.6	Project Budget	13
3.7	Project Timeline	13
4	METHODOLOGY	14
4.1	Design Methodology	14
4.1.1	Sketching of Farm-Bot Layout	15
4.1.2	3D Modeling of Brackets and Base Frame of Farm-Bot	18
4.1.3	Design of Universal Tool	21
4.1.4	Description of UTM	21
4.1.5	UTM Features	21
4.1.6	3D Printing of UTM	22
4.2	Manufacturing Methodology	23
4.2.1	Different Products and Tools Manufactured / used for Fabrication of Farm-Bot	23
4.2.2	Construction of Farm-Bot Structure	36
4.2.3	Working Motions of Farm-Bot	46
5	Automation/Programming	49
5.1	Overview	49
5.2	Basic Components used for Programming	49
5.2.1	Wiring Diagram	56
5.2.2	Block Diagram	58
6	Implementation	59
6.1	Arduino Based Stepper Motor Program	59
6.2	Arduino Based Water Pump Program	60
6.3	Arduino Based Vacuum Pump Program	61
6.4	Arduino Based Gripper Program	62
6.5	Arduino Based Loop Program	63
7	Results and Discussion	71
7.1	Expected Outcome Result	71
7.2	Actual Outcome Result	71
7.3	Technical Review	73
8	Cost Estimation of Project	74

9 Conclusion and Future Scope	76
9.1 Conclusion	76
9.2 Future Scope	76
References	76



List of Figures

3.1	Farm-Bot Flow Chart	11
4.1	Farm-Bot Basic Design Layout	14
4.2	Detail Sketch of Base Frame of Farm-Bot	15
4.3	Detail Sketch of Bracket to join Track plates	15
4.4	Detail Sketch of Bracket to join Track End plates	16
4.5	Detail Sketch of Gantry Wheel plate	16
4.6	Detail Sketch of Gantry Corner Brackets	17
4.7	Detail Sketch of Cross-Slide Brackets	17
4.8	Basic Design of Farm-Bot Layout without Bracketsh	18
4.9	3D Model of Base Frame of Farm-bot	18
4.10	3D Model of Track Joining Brackets as per sketch	19
4.11	3D Model of Track End Brackets as per sketch	19
4.12	3D Model of Gantry Wheel Plate	20
4.13	3D Model of Gantry Corner Plate	20
4.14	Universal Tool Mount	21
4.15	3D Printed UTM	22
4.16	Frame of Farm-Bot	23
4.17	1500mm x 20mm x 40mm 6063-T5 Aluminum V-Slot Track Ex- trusion	24
4.18	1500mm x 20mm x 40mm 6063-T5 Aluminum V-Slot Track Ex- trusion	25
4.19	1200mm x 20mm x 60mm 6063-T5 Aluminium V-Slot Gantry Main Beam	25
4.20	1000mm x 20mm x 20mm 6063-T5 Aluminium V-Slot Z-axis Ex- trusion	26
4.21	Track End Brackets	27
4.22	Track Joining Brackets	27
4.23	Gantry Wheel Plate Assembly	28
4.24	Z-Axis Motor Mounting	29
4.25	Peripheral Mount	30
4.26	Belt Clips	30
4.27	Watering Nozzle And Seed Injecting Tool	31
4.28	V-Wheels	32

4.29	GT2 Timing Belt	32
4.30	20 Tooth GT2 Pulley	33
4.31	5mm to 8mm Flex Coupling	34
4.32	800mm X 8mm Acme Lead Screw	34
4.33	Lead Screw Block	35
4.34	Construction of Frame	36
4.35	Placing of Aluminum Extrusions	37
4.36	Making of Wooden Brackets	37
4.37	Placing of Wooden Brackets	38
4.38	Mounting of Castor Wheels	38
4.39	Mounting of Gantry Column	39
4.40	Mounting of brackets on top of column extrusion	40
4.41	Making and mounting of Cross Slide	40
4.42	Mounting of brackets and coupling to hold motor and lead screw	41
4.43	Making and Mounting of Universal Tool	41
4.44	Placing of GT2 Timing Belt	42
4.45	Mounting of Stopper Plate	43
4.46	Making and Mounting of Seed Holding Tray	43
4.47	Placing of Farm-Dino and Power Supply Box	44
4.48	Placing of Peripheral Mount for Carrying Vacuum pump	44
4.49	Mounting of Water Pump	45
4.50	Final Structure Assembly of Farm-Bot	45
4.51	X-Axis Motion From Stepper Motor to Timing Belt	46
4.52	X-Axis Motion From Timing Belt to V-Wheels	47
4.53	Y-Axis Motion From Stepper Motor-Timing Belt-V-Wheels	47
4.54	Z-Axis Motion From Stepper Motor-Flexible Coupling-Lead Screw	48
5.1	Power Supply Unit	50
5.2	Arduino Mega 2560	50
5.3	Stepper Motor Driver	51
5.4	Servo Driver	52
5.5	Relay Module	52
5.6	Nema 17 Stepper Motor	53
5.7	Soil Sensor	54
5.8	Water Pump	54
5.9	Vacuum Pump	55
5.10	Mechanical Gripper	56
5.11	Wiring Diagram	57
5.12	Block Diagram	58
7.1	Seeding Operation (Taking seed from seed tray)	71
7.2	Seeding Operation (digging of seed in soil)	72

7.3	Watering Operation	72
7.4	Harvesting Operation	73



List of Tables

3.1	Table of Capabilities	11
3.2	Table of Responsibilities	12
3.3	Initial Approximate Project Budget	13
8.1	Table of Cost Estimation	74



Chapter 1

Introduction

In India, near about 70 percentage people are dependent upon agriculture. As compared to other fields globalization in agriculture system is less. So, it is necessary to make some advancement in this field. The idea of robotic agriculture (agricultural environments maintained by good machines) isn't a replacement one. Several engineers have developed driver less tractors within the past however they need not been flourishing as they didn't have the flexibility to hold the complexes. The main motive for developing Agricultural automation technology is the decreasing labor force, a phenomenon common in the developed world. The reasons are the need for improved food quality.

Now a day agricultural operation is automated and also there is commercial availability of automated machinery'sies and robots. For designing a robot, one has to consider two considerations which are precision requirement in the task and environmental conditions such as humidity sensor for irrigation, in which robot needs to work for automating the agricultural operation. To carry out the process of seeding, robot should move in straightway and also be able to modify the distance between seed dropping. Moisture content in soil can affect the digging process; to complete the process sensors should be chosen according the environmental conditions of working.

So, our project Farm-bot is a multifunction Robot that performs three major functions normally required in Agriculture field i.e. Ploughing and Seed distribution, Watering and Agriculture Harvesting. These things are interfaced with Arduino Mega 2560, NEMA 17 stepper motors. The three-axis machine employs linear guides in the X, Y, and Z directions, which allows for tooling such as seed injectors, watering nozzles, sensors, and weed removal equipment to be accurately positioned. Impressively, Farm-Bot can cultivate a variety of crops in the same area simultaneously. Farm-Bot will also be equipped with solar panels which will help in recharging the batteries by natural source of energy. It will also help in decreasing the use of non-renewable sources of energy and will not pollute the environment.

1.1 Purpose

Most agricultural food production in the modern day is performed in large scale, monocrop farms on huge plots of land. While it has been streamlined to produce huge amounts of food at a relatively cheap price, monocrop farming puts a significant strain on the soil and the surrounding environment by using up specific nutrients for different crops, as well as using tremendous amounts of water. The idea with Farmbot is to shift dependence on large scale agriculture by giving people the ability to cultivate their own plants with little to no actual physical labour on their part. Farmbot would be able to feed water to each plant as needed based on an database programming. This means that, with Farmbot, a person with little to no actual gardening experience could have the home-garden of their dreams with no more effort than a few taps on the screen of a tablet computer.

1.2 Project Scope

We narrowed down the scope of our project to the development of three main systems for Farmbot: (1) seed planting mechanism(s), (2) watering system, and (3) Harvesting system. While creating solutions for these main functions, we hoped to the cost of Farmbot. We also List down what will be customer requirements and depend on that our Farmbot Specifications.

Customer Requirements:-

- Easy to install or pre-installed tool components.
- Easy to operate and maintain..
- Easy to operate and maintain.
- Low cost.
- Safe for people in the event of an accident.
- Must not look ugly.
- Minimum installation time.
- Information, research, and development is open source.
- Easy for customers to independently manufacture certain parts and tools.

Engineering Specifications:-

- Tool mount accommodates watering and seeding nozzles and universal tool holder

- Watering and seeding nozzles can be controlled to eject their contents when desired and how much.
- Prototype accommodates at least one stock of one type of plant seed.

1.3 Project Goals and Objectives

- Agricultural automation using Farmbot is an attempt to reduce the burden of maintaining a farm for small scale and large scale alike by automating the most commonly performed tasks such as sowing of seeds, watering of plants and finally even removing weeds or collecting root vegetables.
- The primary aim of our project is to develop a multitasking agricultural robot, which can be used for agricultural processes like digging the soil, seed sowing, crop cutting(harvesting) and irrigation system. keeping in mind low cost and more efficient.
- The project aim to "create open and accessible technology aiding everyone to grow food and to grow food for everyone ."
- This automated robotic machine which is named as "Farm-Bot" is specially designed to facilitate the peoples so that the demand of food can be met easily. Agriculture robot serves better result than manual system. It is an automated robot which works on the basis of size of field, size of seed and in which mode it is meant to be operated.

Chapter 2

Literature Survey

2.1 Paper Title 1

Farmbot-a Smart Agriculture Assistor Using Internet of Things

P.Hemalatha, K.Dhanalakshmi, S.Matilda and M.Bala Anand

2.1.1 ABSTRACT

Savvy cultivating is an idea rapidly getting on in the farming nowadays. Offering high-accuracy crop control, valuable information gathering, automated farming devices and mechanized cultivating procedures, there are plainly many preferences an organized ranch has to facilitate. Robots are assuming to be a critical part in the field of agriculture for making the cultivating process self-governing. In this paper, a multitasking Farm-Bot is proposed to integrate agriculture process in a single robotic application and take decisions with help of cloud services. The proposed IoT framework is organized keeping the belief that various little self-sufficient machines could be more effective than customary huge tractors and human exertion. In low-cost, the modular robot can perform live streaming of crops, seed sowing, pesticide sprinkling and automatic irrigation. In addition, this venture attempted to monitor parameters associated with plants and crops such as the moisture level, humidity, temperature etc through sensors and upload the same to a cloud database and additionally alert and update the owner of the plantation regarding the same. The information obtained was stored and graphically plotted and processed with APIs. Thus, by the proposed Farm-Bot, farmers can able to get updates about the field and by switching onto the desired modes (irrigation, sowing and sprinkling) through dashboard, the energy, salary

2.1.2 INTRODUCTION

Agribusiness is considered as the pioneer of life for the human beings as it is the central origin of food grains and other raw materials. Of the many points of interest, IoT conveys to the table, its capacity to advance the trends of current cultivating pro-

cedures in agriculture is completely notable. IoT sensors fit for furnishing agriculturists with data about harvest yields, precipitation, destination and soil sustenance which are important to revenue generation and offer exact information which can be utilized to enhance cultivating procedures over time. Traditional strategies rely upon human power for lifting, dragging, weed control, harvesting. People are inclined to work in unsafe condition while splashing chemicals and pesticides. The tractors that minimal the farming actions are bigger in weight and can't move in territory conditions. Development in agriculture is important for the improvement of the financial state of the nation. Inopportunately, various farmers still utilize the regular techniques for cultivating which brings about low yielding of harvests and revenue. In any case, wherever mechanization has been actualized and individuals have been superseded by programmed apparatuses, the yield has been moved onward. Thus, the agriculturists have to actualize present-day science and innovation in the agriculture segment for expanding the yield. Monitoring environmental factors aren't sufficient and complete elucidation to enhance the yield of the products. There are number of different components that influence the productivity to an incredible degree. These components fit in mugging of creepy crawlies and pests which can be controlled by showering the product with appropriate pesticides. Besides, assault of wild creatures and feathered creatures at the point when the product grows up. There is likewise plausibility of robberies at the point when the crop is in the phase of collecting. Indeed, even after collecting, agriculturists additionally meet head-on issues away of reaped harvest. Along these defenses, remembering the true objective to give answers for every such issue, it is imperative to make an organized system which will manage all parts impacting the gainfulness in each stage. This paper hence proposes an osteology which is valuable in checking the field information as well as scheming the field operations which gives the adaptability. The paper goes for influencing agribusiness to savvy utilizing robotization and IoT advancements. A mechanized farming framework (which utilizes field robot) is exemplified from above issues. Robots can work fretfully in all situations as they are customized to play out the coveted movements using advanced microcontrollers such as Raspberry Pi. The lightweight of the robot is a noteworthy preferred standpoint since they don't minimize the dirt as huge apparatus does. Agrarian Automation with Field Assisting Robot is extremely basic systems, where many instruments are coupled together and the water system framework is completely automated. =

2.1.3 CONCLUSION

The sensors and microcontrollers of every one of the modes are effectively interfaced with raspberry pi and remote correspondence is accomplished between different nodes. Venture points on the outline, advancement and manufacture of a multitasking robot which can perform programmed furrowing, seed apportioning and sprinkling. The procedure of the picture can be improvised by preparing in organic

product picking which accomplishes a high-quality item. Servo component in seed administering permits to control the stream of seeds. This venture aims to diminish the prerequisite of substantial labor and cost of gear, making it reasonable to ranchers. The framework helps in the diminishment of work expenses and limitations on working hours can be altogether made strides. The rural robot is intended to encourage the agriculturists to facilitate their work. Once the idea of computerization in farming is acknowledged, the selection rates will turn out to be high and the expenses of innovation will descend.

2.2 Paper Title 2

AUTOMATED FARMING ROBOT

Authors:- S.Gopinath, Kavinraja G, Bala Ganesh R, Aravindhan S, Krisna Prashatt G

2.2.1 ABSTRACT

Farmbot is a robot designed for agricultural purposes. As one of the trends of development on automation and intelligence of agricultural machinery in the 21st century. This Bot can perform basic elementary functions like ploughing, seed sowing, spraying. We are applying the idea of robotics technology in agriculture. We can expect the robots performing agriculture operations autonomously watching the farms day and night for an effective report. It is designed to minimize the labour of farmers in addition to increasing the speed and accuracy of the work.

2.2.2 INTRODUCTION

Here were fabricating this concept is mainly reducing the manual effort and increasing the efficiency while the operations of the farmers. Agriculture is cultivation of animals, plants, fungi, and other life forms for food, fibre, bio fuel, medicinal and other products used to sustain and enhance human life. Agriculture was the key development in the rise of sedentary human civilization, whereby farming of domesticated species created food surpluses that nurtured the development of civilization. The study of agriculture is known as agricultural science. The history of agriculture dates back thousands of years, and its development has been driven and defined by greatly different climates, cultures, and technologies. However, all farming generally relies on techniques to expand and maintain the lands that are suitable for raising domesticated species. For plants, this usually requires some form of irrigation, although there are methods of dry land farming. Livestock are raised in a combination of grassland-based and landless systems, in an industry that covers almost one-third of the world's ice- and water-free area. In the developed world, industrial agriculture based on large-scale monoculture has become the dominant system of modern

farming, although there is growing support for sustainable agriculture, including permaculture and organic agriculture.

2.2.3 CONCLUSION

This project is made with pre-planning, that it provides flexibility in operation. This innovation has made the more desirable and economical. This project “AUTO-MATED FARMING BOT” is designed with the hope that it is very much economical and help full to agricultural fields. This project helped us to know the periodic steps in completing a project work. Thus, we have completed the project successfully.

2.3 Paper Title 3

Farmbot, a Small-Scale Autonomous Farming Machine: Software Challenges

Authors:- Johann Bourcier, Univ. Rennes 1, France; Olivier Barais, Univ. Rennes 1, France; Nicolas Harrant, Univ. Rennes 1, France; Alexandre Rio , Univ. Rennes 1, France; Benoit Combemale, Univ. Toulouse, France.

2.3.1 ABSTRACT

A Farmbot1 is a small scale fully automated farming system. The FarmBot is a complete open source project providing an easy access to small scale local farming. The current size of the farming landscape is 1.5-meter-wide by 3 meters long. Using this open-source project, family or professional are able to automatically grow their own vegetable by automating all the repetitive tasks of precise seeds planting and watering, removing weeds, etc. Figure 1 shows a working prototype of the farmbot project.

2.3.2 INTRODUCTION

Technically, a Farmbot system can be seen as a farming Computer Numerical Control (CNC) machine. The Farmbot system embeds two main computing units: an embedded computer (a raspberry Pi), and a micro-controller (an Arduino mega). From a software perspective, the Arduino hosts software to directly control the motors, and all actuators and sensors of the system. It provides an API reusing standard protocols over a serial link. The raspberry Pi is in charge of automating, coordinating and scheduling all the tasks of the farming machine which are then delegated to the Arduino. The raspberry Pi is also in charge of image processing to detect weeds, and provides an API to discuss with the cloud hosted software part. Finally, a web application is hosted on the cloud and provides connection to external knowledge such as the crop growing needs, the local weather forecast, the decision-making support, and a web user interface.

2.3.3 CONCLUSION

The Farmbot system is a very interesting connected object which has a societal impact through a paradigm shift for local food production. It also has many interests from a research perspective in the software engineering community since it represents a fantastic experimental case study for various open research problems in modern heterogeneous and distributed software which interact directly with our physical environment. In particular we draw in this paper several possible extensions of the Farmbot that raise software engineering challenges, such as the design and integration of deferent domain-specific languages, the composition of various kinds of models, and the computation of complex relations and correlations from such a set of models.

2.4 Paper Title 4

FARMBOT – SMALLSCALE, LOW COST FARMING AUTOMATION SYSTEM

PROJECT REFERENCE NO: 39SBE1871

Authors:- MR. Chethan M MR. Amaresh G MR. Anudeep C MR. Krishna

2.4.1 INTRODUCTION

Agricultural automation using Farmbot is an attempt to reduce the burden of maintaining a farm for small scale and large scale alike by automating the most commonly performed tasks such as sowing of seeds, watering of plants and finally even removing weeds or collecting root vegetables. In addition to all of the above the architecture of Farmbot is modular i.e. there is a pick and place arm which is free to move in circular and vertical direction, mounting this arm on a moving platform gives this system freedom of movement along 3-axis. Automation is the technique, method or system of operating or controlling a process by highly automatic means, as by electronics devices, reducing human intervention to a minimum. Modular architecture refers to the design of any system composed of separate components that can be connected together. The beauty of modular architecture is that you can replace or add any one component (module) without affecting the rest of the system. The area of digital electronics and intelligent systems, automation using robot has become one of the fastest developing application-based technologies in the world. The incorporation of the mobile communication technologies into the automation systems, now allows the users to use mobile application on their phone to control their farms (taken as example) from distance.

2.4.2 CONCLUSION

Implementation of the wireless control is done with the help of the Bluetooth HC-05 module. Controlling of the various modules (motors) are done by receiving the commands over the Bluetooth from Android mobile application. Once the commands are received, the microcontroller sends a digital signal to the respective port pins in the microcontroller, these are in turn connected to the enable pins of L293 Motor driver boards, which drive the respective motors. The figure 7 shows the Farmbot with all the different components labelled. The robot designed in this project is connected to the user mobile phone over Bluetooth link therefore it is limited to the Bluetooth range, this can be extended with the help of a GSM module in the place of a Bluetooth receiver. When the application is first launched, the user is greeted with a login screen that can be unlocked by entering the username and password. The application also displays required notifications to display the current command being transmitted to the Microcontroller via Bluetooth. The agriculture automation system has been designed and realized using a simple model controlled over the Bluetooth signal from Android Mobile Phone. The designed system is a low-cost demonstration model, which is able to convey the application and future scope for modular automated agriculture systems. This demonstration system was made at a low cost and was tested successfully to grow small crops.

2.5 Technical Review

We are using the reference of paper 3 for our project in which the Farm-bot is generally used for small scaling farming. So, our main objective of this project is to design Farm-Bot in such a way that it can be used for Terrace Farming, Roof Farming as well as Backyard Farming.

2.5.1 Reasons to use this Technology

The main objective of the system is to design and implement a scale model of a cheap and easily available open source agriculture automation system that conforms autonomous robot agriculture mainly concentrating on modular structure and centralized structure.

Chapter 3

Project Planning

3.1 Members and Capabilities

Table 3.1: Table of Capabilities

SR. No	Name of Member	Capabilities
1	Ashar Ansari	Buying, Market Survey
2	Umer Bhikan	Fabrication, Designing
3	Omkar Choughule	Designing, Documentation
4	Abhijit Kadam	Fabrication, Documentation

Work Breakdown Structure

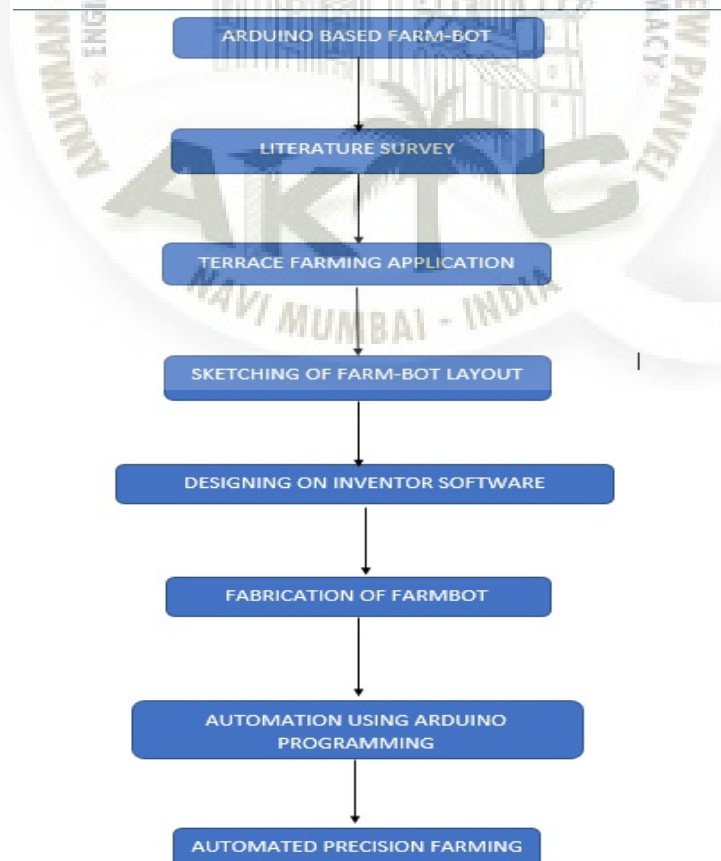

Figure 3.1: Farm-Bot Flow Chart

3.2 Roles and Responsibilities

Table 3.2: Table of Responsibilities

SR. No	Name of Member	Role	Responsibilities
1	Abhijit Kadam	Project Leader	Fabrication, Documentation
2	Omkar Choughule	Project Member	Designing, Documentation
3	Umer Bhikan	Project Member	Fabrication, Designing
4	Ashar Ansari	Project Member	Buying, Market Survey

3.3 Assumptions and Constraints

Before the start of the project we discussed the schedule of Project Work and based on that we prepared project Schedule .While doing the project we were having certain constraints i.e. our college is far from market hence to buy something we had to travel from Panvel to Turbhe or CST depend on requirement hence for that purpose we allotted one group member for buying purpose also their was limit provided to issue the lab. that is we can work in project lab till 7 PM. As some of us had to travel long way to reach home from college based on capability and constrains of each individual the task has been allotted

3.4 Project Management Approach

Project was perfectly guided by our guide he distributed the work as per every ones caliber. we had a team leader who managed the project he gave the work to everyone and also restricted the time limit so that the project will be on time and up to date. we all did our job as per said by the guide and completed it successfully. In our group We had to go to guide once in a week.

3.5 Ground Rules for the Project

There were certain rules which is set by guide and team leader which are:

- 1. Everyone should remain present during the project schedule planned.
- 2. Everyone should know about each and every activity being carried out.
- 3. All four members should remain present during the meeting with guide.
- 4. Team should maintain daily diary during the course of project.

3.6 Project Budget

Table 3.3: Initial Approximate Project Budget

SR. No	Category	Price
1	Extrusion	6,500/-
2	Electronic Circuits	20,000/-
3	Drive Trains	12,000/-
4	Aluminum Brackets	10,000/-
5	Hardware and Fasteners	1,500/-
6	Tubing	2,000/-
7	Miscellaneous	1,500/-
=	Total	53,500/-

Our Initial Approximate Project budget was above 50K so along with project completion our another aim was to reduce the cost of project as much as possible at least around 30-35K.

3.7 Project Timeline

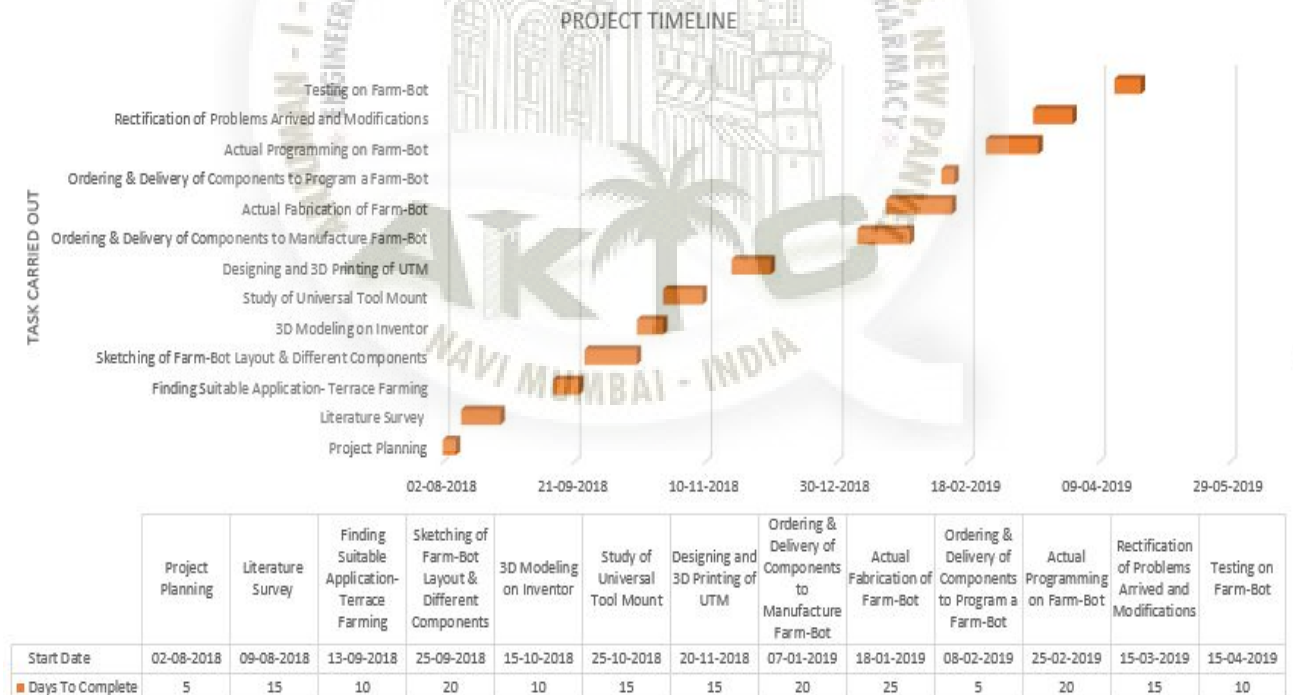

Chapter 4

METHODOLOGY

4.1 Design Methodology

From the Open Source where we have taken the reference for our project, there they have designed it for backyard purpose which was on extra large scale. But we have cut it down as per our need which is for the Terrace having the area of 2.5M Square and we are designing it of 1.8m² area.

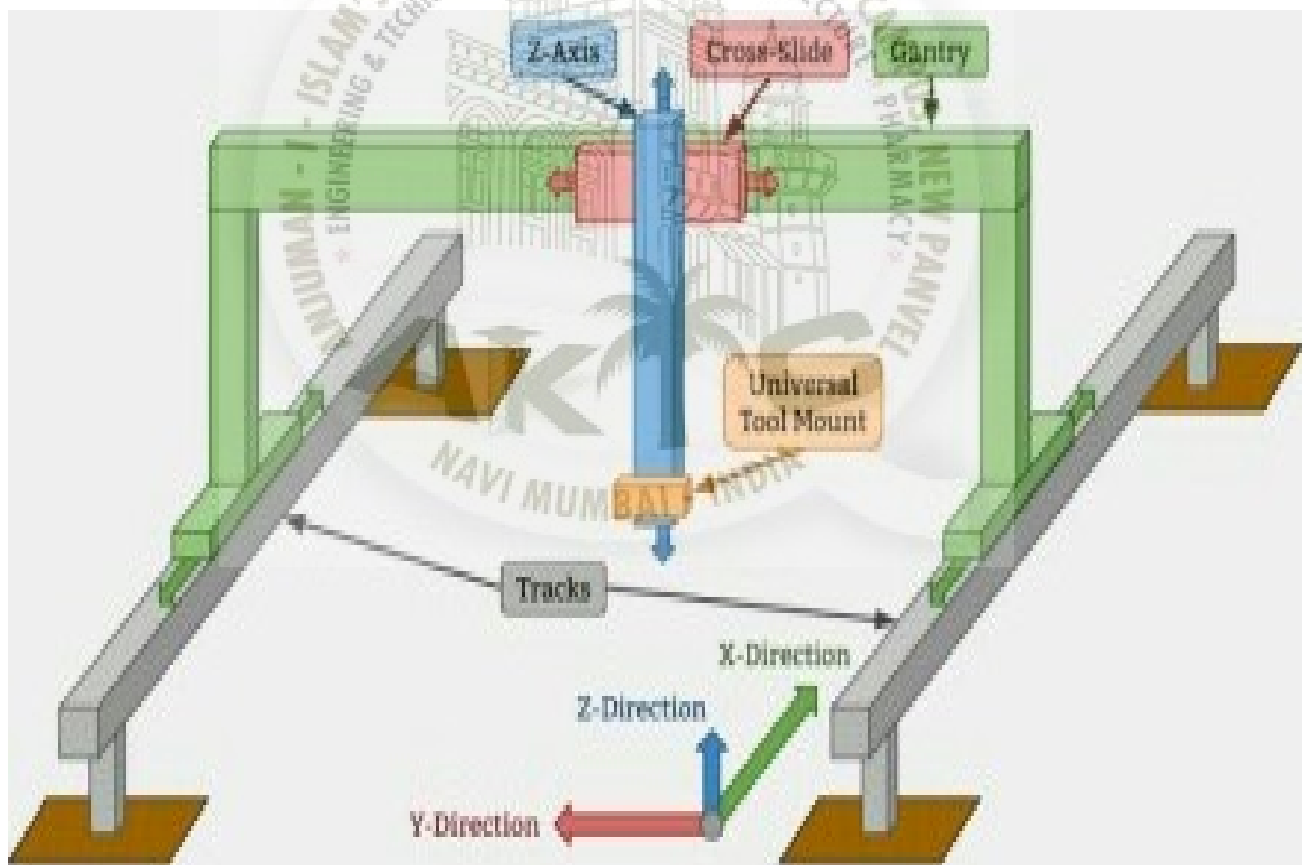

Figure 4.1: Farm-Bot Basic Design Layout

4.1.1 Sketching of Farm-Bot Layout

We have made first rough sketches of Base Frame and brackets to join extrusion with body of farm-bot. those sketches are as follows:-

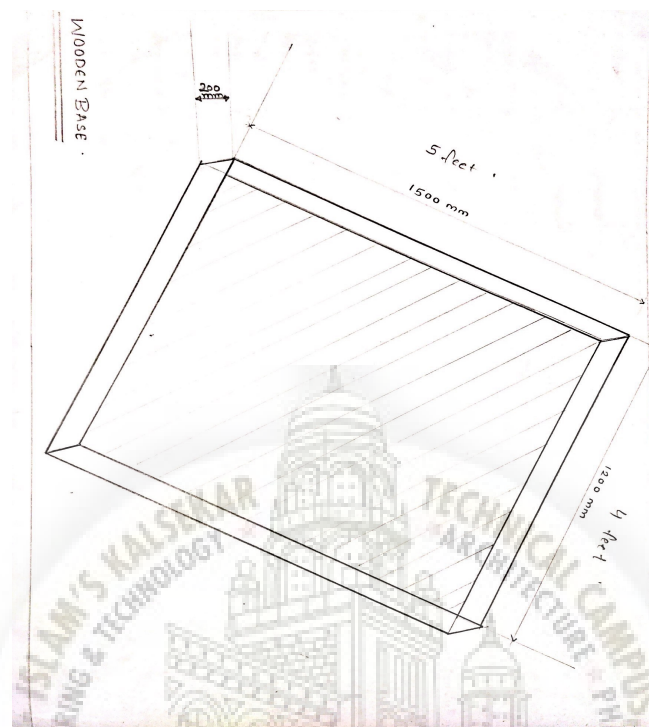

Figure 4.2: Detail Sketch of Base Frame of Farm-Bot

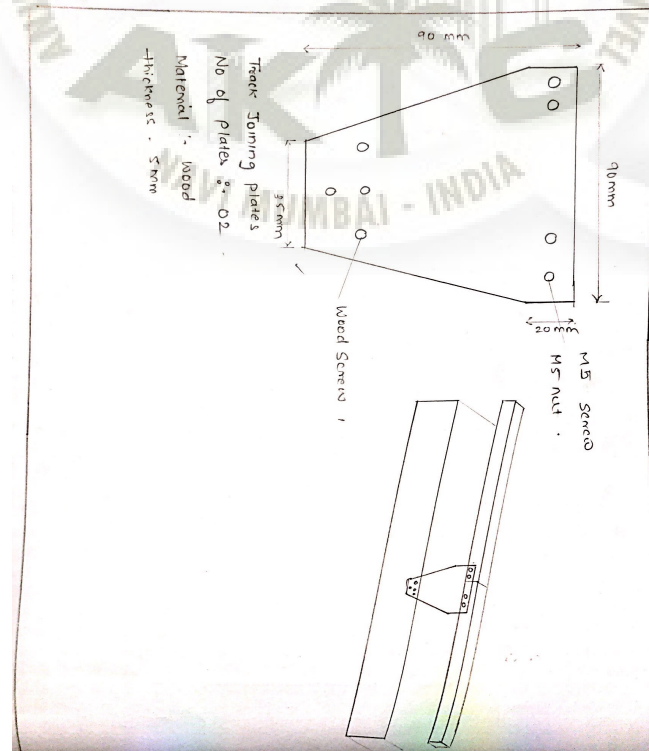

Figure 4.3: Detail Sketch of Bracket to join Track plates

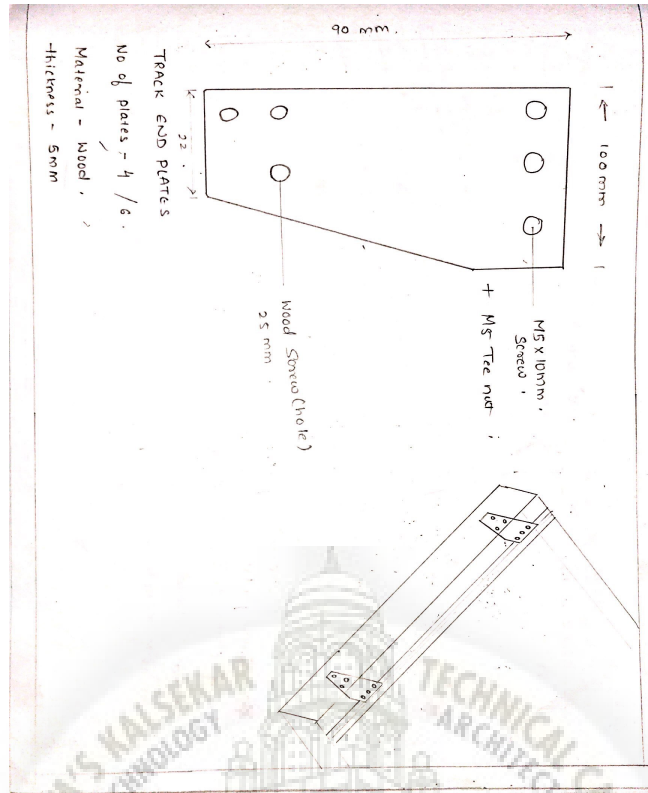

Figure 4.4: Detail Sketch of Bracket to join Track End plates

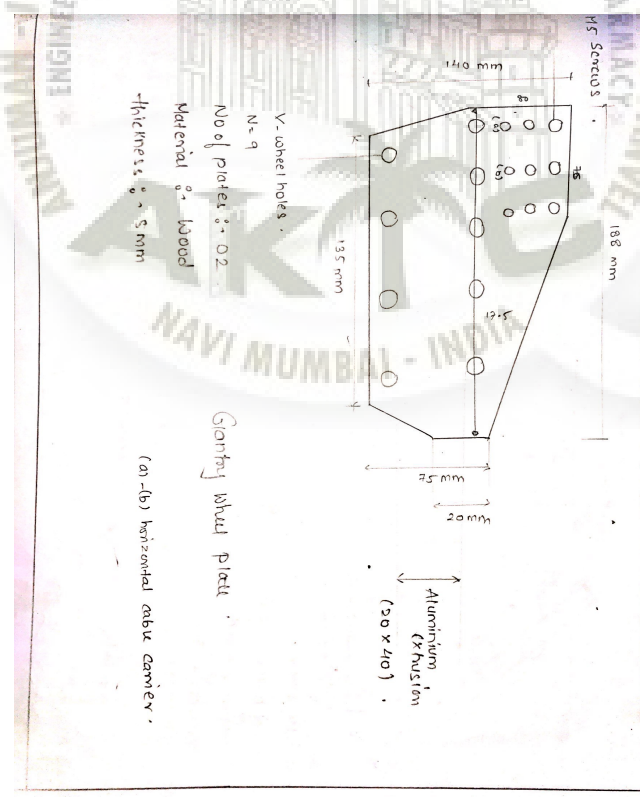

Figure 4.5: Detail Sketch of Gantry Wheel plate

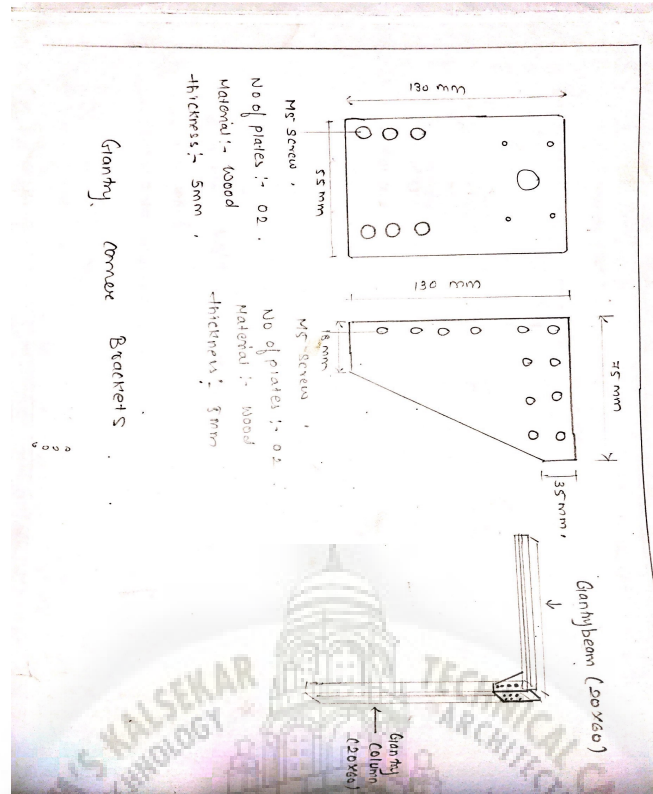

Figure 4.6: Detail Sketch of Gantry Corner Brackets

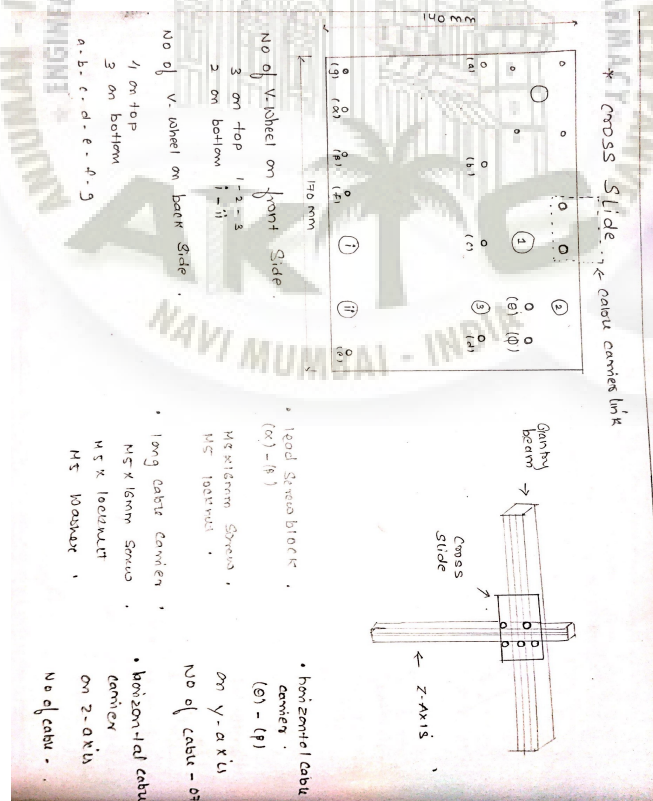

Figure 4.7: Detail Sketch of Cross-Slide Brackets

4.1.2 3D Modeling of Brackets and Base Frame of Farm-Bot

We have first model the Farm-Bot using Some Assumptions and Considerations for our comfort of design for project. The 3D Modeled Farm-Bot is of Size 1200*1500 mm² of Area. it as as shown in fig.

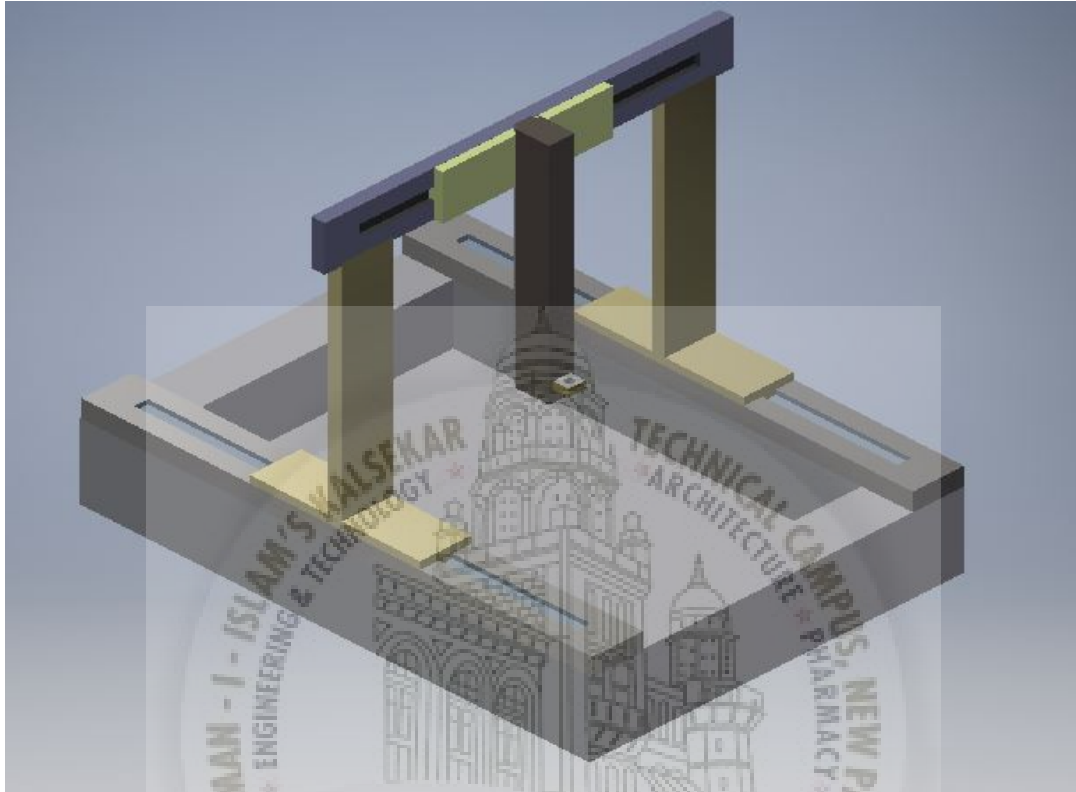

Figure 4.8: Basic Design of Farm-Bot Layout without Bracketsh

We also Modeled Brackets use for Joining Extrusions With base of Farm-Bot to have an idea about how it looks, and also assists for Manufacturing these brackets from Wood. as Aluminum Brackets are too costly we have avoided it and made it from wood itself.

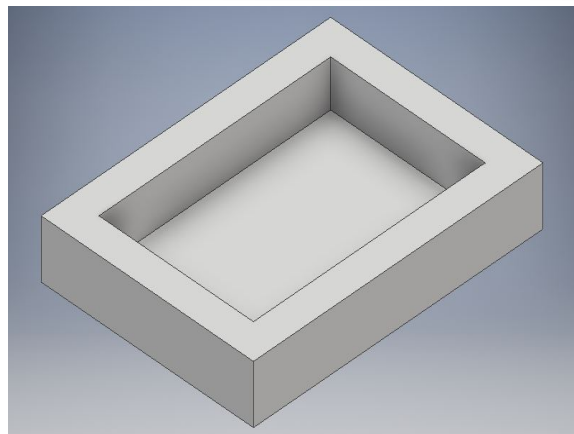

Figure 4.9: 3D Model of Base Frame of Farm-bot



Figure 4.10: 3D Model of Track Joining Brackets as per sketch

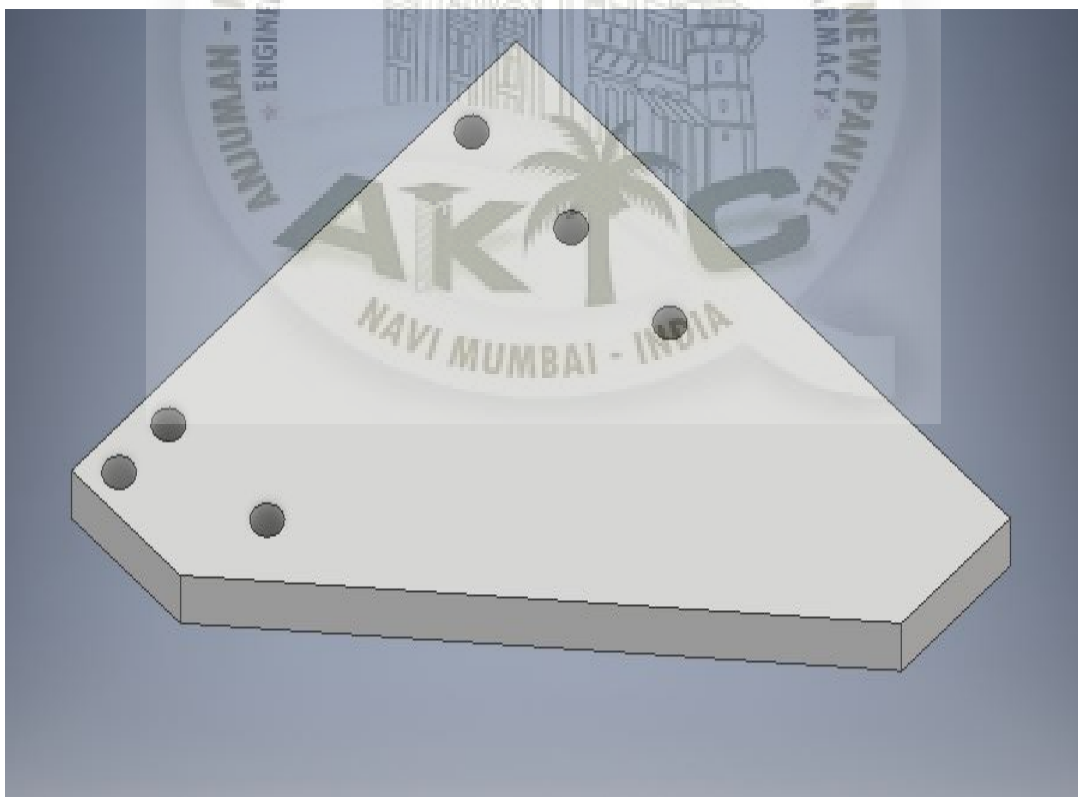

Figure 4.11: 3D Model of Track End Brackets as per sketch

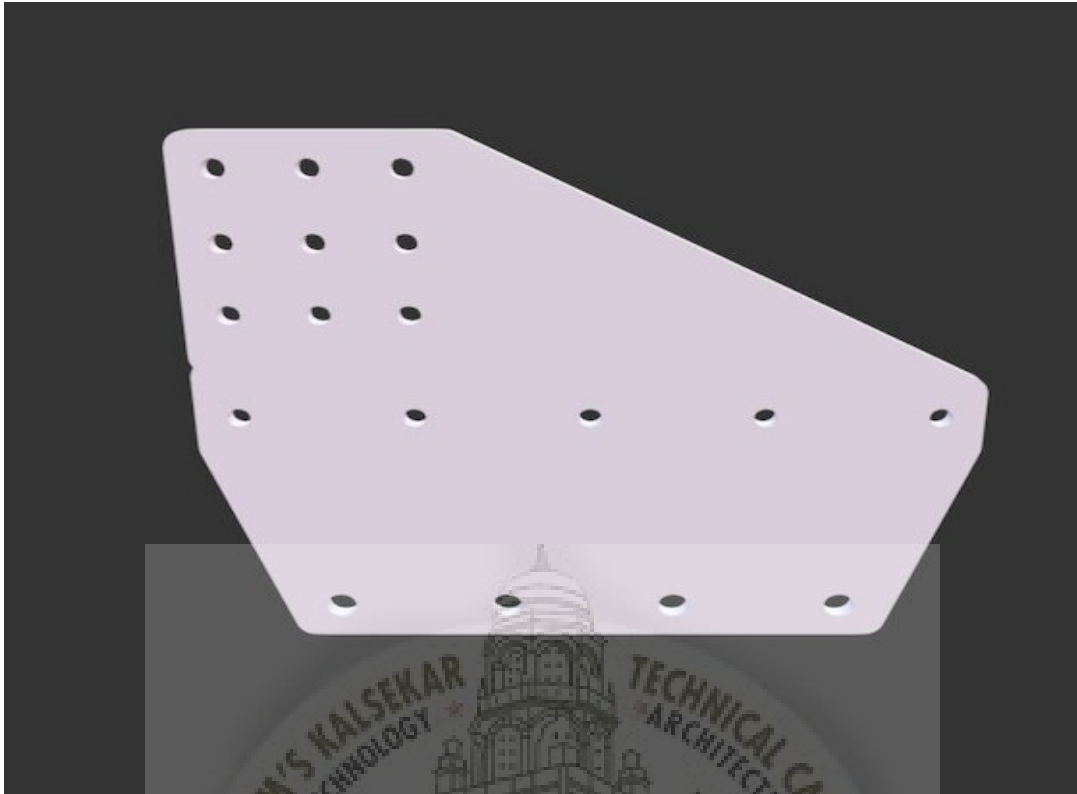

Figure 4.12: 3D Model of Gantry Wheel Plate

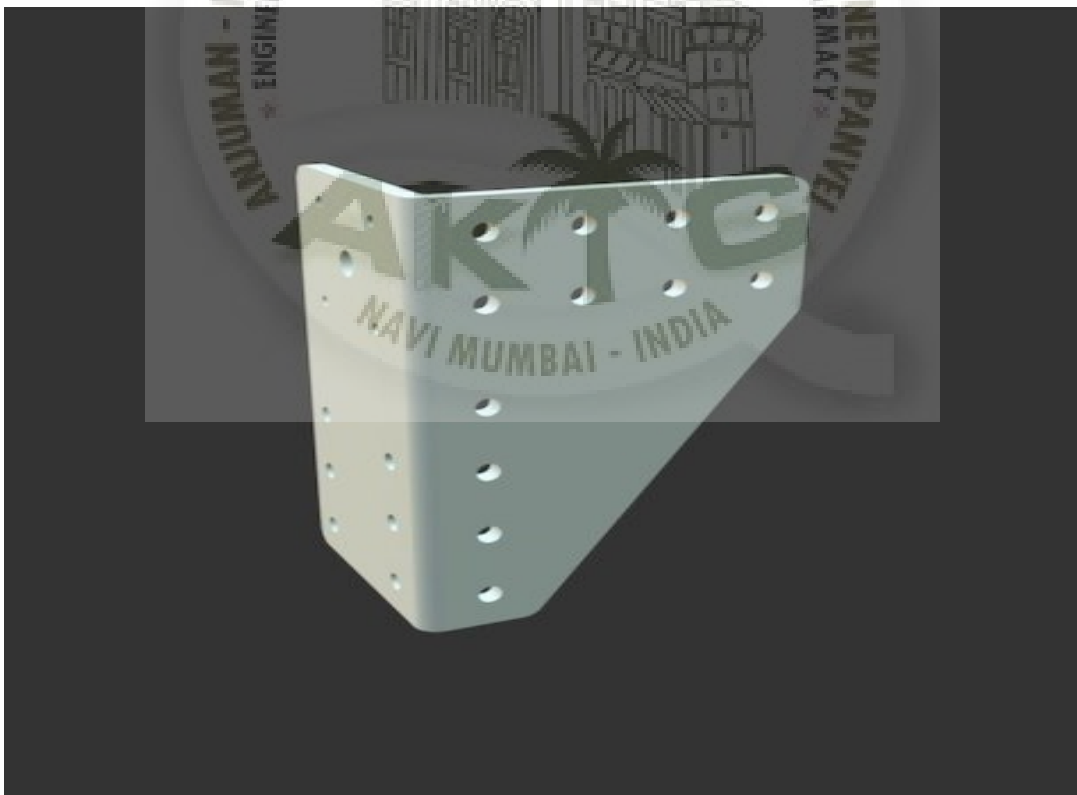

Figure 4.13: 3D Model of Gantry Corner Plate

4.1.3 Design of Universal Tool

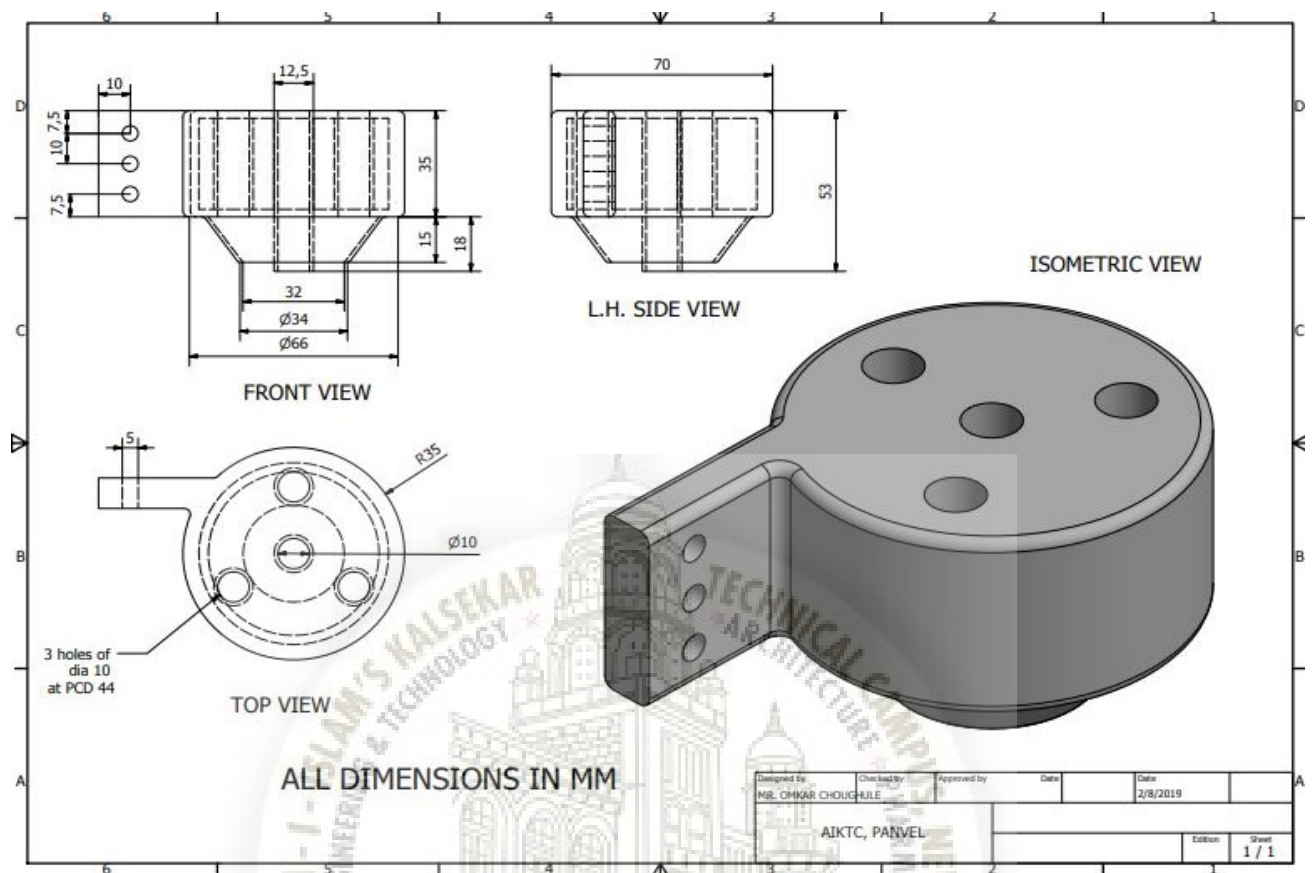

Figure 4.14: Universal Tool Mount

4.1.4 Description of UTM

UTM (Universal Tool Mount), Farmbot requires a universal tool mount system to perform a broad range of tasks. such as Watering, Seed Sowing Harvesting. So in order to perform this, one could say that we require three different tools to perform this operations. Which increases its complexity, so we came to the conclusion that we have to design a tool which can commonly perform watering as well as Seed sowing operations. Which in turn gives flexibility to Farm-Bot and also can perform on a single co-ordinate system for both operations. For harvesting we are using mechanical gripper.

4.1.5 UTM Features

UTM as shown in fig. is Designed in such a way that it performs both Seeding and Watering functions simultaneously. As shown in fig. there are 3 holes of Dia. 10 at PCD 44 which are the outputs of water pump. These three holes directs and assist the water coming from water carrier to water pump and funnel shape provided at the

bottom of UTM concentrates this water at controlled amount on a precise location of Crops.

The centre hole is the output of Vacuum Pump. Vacuum pump creates suction and needle at the bottom of UTM sucks the seed and holds it until UTM reaches to the pre-determined location where seed needs to be dig into soil. once UTM reaches to the desired location this needle dig into the soil and Vacuum pump turns off and seed is left into the soil.

4.1.6 3D Printing of UTM

There are multiple ways to manufacture UTM, but to learn new technology and for its advantage of light weight and anti-corrosive properties we had decided to manufacture UTM by 3D Printing Technology.

It basically requires you to convert your CAD model into Stereolithography model (.stl) files and then with the use of softwares such as CURA, Slicer, Blender Converts this cad model/3D model into number of slices and with the use of CNC CO-ordinate system CAD model manufactured into real time Actual 3D model.

Stereolithography (SLA or SL; also known as stereolithography apparatus, optical fabrication, photo-solidification, or resin printing) is a form of 3D printing technology used for creating models, prototypes, patterns, and production parts in a layer by layer fashion using photochemical processes by which light causes chemical monomers to link together to form polymers.



Figure 4.15: 3D Printed UTM

4.2 Manufacturing Methodology

From the various sketches, and 3D models which we have prepared, now we are ready to move on to the next stage that is Manufacturing. In order to Manufacture we require to create different Products and finally Combine it to get Final Assembly of Farm-Bot.

4.2.1 Different Products and Tools Manufactured / used for Fabrication of Farm-Bot

1. Frame

First we took two pieces of plywood. The plywood was cut into strips that were used to make the side walls of the frame. Second plywood was used to make the base of the frame. Below the frame four castor wheels are attached to the base to carry the body from one place to another. Screws were used to join the strips.

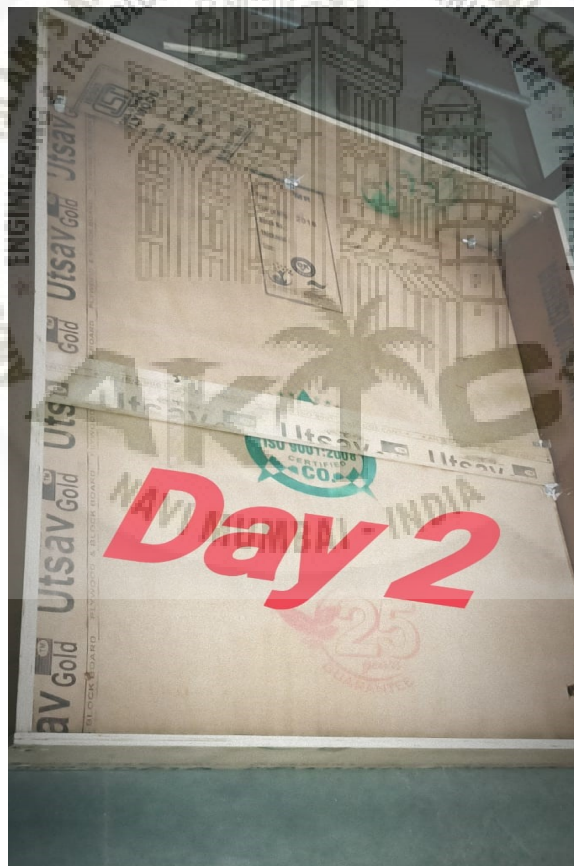

Figure 4.16: Frame of Farm-Bot

- Material:- Plywood
- Quantity:- 1
- Profile:- 1500mm x 1200mm

2. Extrusions

A. Track Extrusion

Track extrusions are the primary structural component of the tracks sub-assembly. They can be combined end-to-end in order to create longer tracks. The gantry v-wheels roll along the track extrusions, allowing FarmBot to move in the x-direction.



Figure 4.17: 1500mm x 20mm x 40mm 6063-T5 Aluminum V-Slot Track Extrusion

- Material:- 6063-T5 Aluminum
- Quantity:- 1000mm x 2 , 500mm x 2
- Profile:- 20mm x 40mm V-Slot
- Length:- 1500mm

B. Column Extrusion

The gantry columns are made from aluminum extrusions. They can be scaled to be taller or shorter to satisfy your needs. The two large spaces inside the columns are used to conceal and protect the GT2 timing belts that run along the tracks and up to the gantry pulleys.



Figure 4.18: 1500mm x 20mm x 40mm 6063-T5 Aluminum V-Slot Track Extrusion

- Material:- 6063-T5 Aluminum
- Quantity:- 2
- Profile:- 20mm x 60mm V-Slot
- Length:- 500mm

C. Gantry Main Beam

This aluminum extrusion serves as the gantry's primary structural element. The cross-slide's v-wheels move across this extrusion, allowing FarmBot to move in the y-direction.



Figure 4.19: 1200mm x 20mm x 60mm 6063-T5 Aluminium V-Slot Gantry Main Beam

- Material:- 6063-T5 Aluminum
- Quantity:- 1000mm x 1, 200mm x 1
- Profile:- 20mm x 60mm V-Slot
- Length:- 1200mm

D. Z-axis extrusion

This aluminum extrusion allows FarmBot to accurately position the tool-mount and tools in the z-direction. It slides through the vertically aligned wheels on the front of the cross-slide.

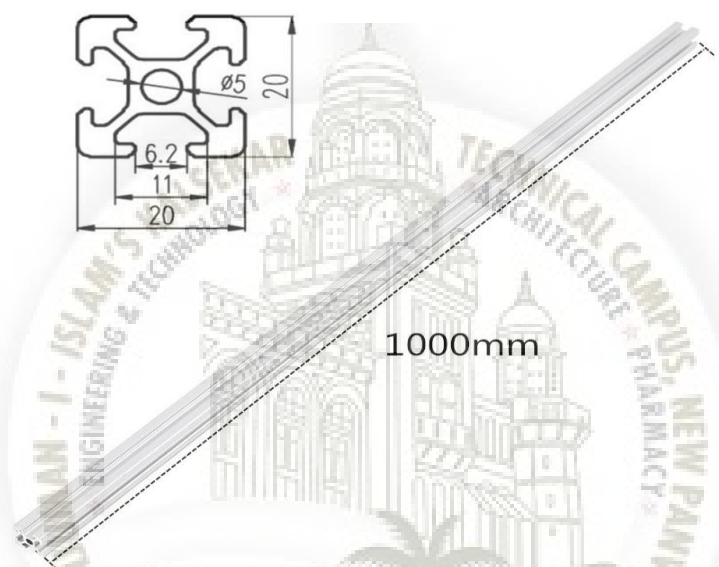

Figure 4.20: 1000mm x 20mm x 20mm 6063-T5 Aluminium V-Slot Z-axis Extrusion

- Material:- 6063-T5 Aluminum
- Quantity:- 1
- Profile:- 20mm x 20mm V-Slot
- Length:- 1000mm

3. Plates and Brackets Different brackets were made from wood. Some of these brackets are used to fix the track extrusions, while some are mounted on column extrusions with V-groove wheels on it for movement of the Gantry column along X-axis.

A. Track End Brackets

These plates are connected at the end of the track extrusions.



Figure 4.21: Track End Brackets

- Material:- Wood
- Quantity:- 4
- Thickness:- 3cm

B. Track Joining Brackets

These plates are used to join two parts of track extrusions.



Figure 4.22: Track Joining Brackets

- Material:- Wood
- Quantity:- 4
- Thickness:- 3cm

C. Gantry Wheel Brackets

These plates have V-wheels on it for movement of the gantry along x-axis.



Figure 4.23: Gantry Wheel Plate Assembly

- Material:- Wood
- Quantity:- 2
- Thickness:- 3cm

D. Gantry Corner Plates

These plates are made in two parts one plate is used as motor mounting and one is used to join main gantry beam with the vertical columns.

- Material:- Wood
- Quantity:- 2
- Thickness:- 3cm

E. Cross Slide Plate

This allows movement of z-axis along y-axis direction. Various wheels are mounted on it for its motion on main gantry beam.

- Material:- Wood
- Quantity:- 1
- Thickness:- 3cm

F. Z-Axis Motor Mount

We have made use of plywood as motor mount and a L-shaped aluminium bracket to fix the motor mount on z-axis extrusion.



Figure 4.24: Z-Axis Motor Mounting

- Material:- Wood
- Quantity:- 1
- Thickness:- 3cm

G. Peripheral Mount

This component is used to mount the vacuum pump to the z-axis extrusion and the solenoid valve to a gantry column.



Figure 4.25: Peripheral Mount

- Material:- Wood
- Quantity:- 1
- Thickness:- 3cm

H. Belt Clips

These clips are used to keep the belts under tension and to keep the belt always tight on the wheels.



Figure 4.26: Belt Clips

- Material:- Aluminum
- Quantity:- 6
- Thickness:- 3-5mm

4. Watering Nozzle and Seed Injecting Tool

As shown in the figure there are three holes for watering purpose and one hole at the center through which vacuum is created and seeding action takes place. The seeder, combined with the vacuum pump, allows FarmBot to pick up seeds and deposit them precisely in the ground. The nozzle at the bottom allows concentrated water supply.



Figure 4.27: Watering Nozzle And Seed Injecting Tool

- Material:- 3D Printed Plastic

5. Drivetrain

A. V-Wheels

These polycarbonate V-wheels are precision machined to allow FarmBot to move in the X, Y, and Z directions smoothly and precisely. Each wheel comes pre-assembled with two stainless steel rubber-sealed ball bearings and one M5 precision shim.



Figure 4.28: V-Wheels

- Wheel Material :- Polycarbonate
- Wheel Quantity :- 30
- Wheel Dimensions:- 23.9mm OD, 16mm ID, 10.23mm Thickness
- Bearing Material :- Stainless Steel
- Bearing Dimension :- 16mm OD, 5mm ID, 5mm Thickness
- Bearing Seal :- Rubber sealed

B. GT-2 Timing Belt

Timing belt used to assist V-wheels to guide on a given path.



Figure 4.29: GT2 Timing Belt

- Material :- Neoprene with Fiberglass Cords
- Quantity :- 1
- Dimensions:- 5m Roll
- Width :- 5mm
- Thickness:- 00.75 Thickness
- Pitch :- GT2 (2mm)

C. 20 Tooth GT2 Pulleys

These pulleys are attached directly to NEMA 17 stepper motor shafts or onto the driveshaft. They transfer power from the motor to the belt such that FarmBot can move in the X and Y directions.



Figure 4.30: 20 Tooth GT2 Pulley

- Material :- Aluminum
- Quantity :- 3
- Dimensions:- 5mm ID ; 15mm OD
- Height :- 14mm
- Number of Teeth :- 20
- Pitch :- GT2 (2mm)

D. 5mm to 8mm Flex Coupling

This aluminum coupling connects the Z-axis stepper motor to the leadscrew to allow FarmBot to move in the Z direction.



Figure 4.31: 5mm to 8mm Flex Coupling

- Material :- Aluminum
- Quantity :- 1
- Dimensions:- 5-8mm ID ; 18mm OD
- Length :- 25mm

E. 8mm ACME Lead Screw

Lead Screw used to assist the movement of Z-Direction.



Figure 4.32: 800mm X 8mm Acme Lead Screw

- Material :- Stainless Steel
- Quantity :- 1
- Dimensions:- 8mm Dia
- Length :- 800mm
- Threads:- Tr8*8-2p (4 starts)
- Lead:- 8mm
- Pitch:- 2mm

F. Lead Screw Block

This delrin block attaches to the cross-slide plate so that the lead screw can move through it, allowing FarmBot to move in the Z direction.



Figure 4.33: Lead Screw Block

- Material :- Delrin
- Quantity :- 1
- Dimensions:- (34*20*12)mm
- Hole Dia :- 8mm
- Threads:- Tr8*8-2p (4 starts)
- Lead:- 8mm
- Pitch:- 2mm
- Mounting Holes:- M5, 20mm apart

4.2.2 Construction of Farm-Bot Structure

we began our manufacturing by making of wooden base or box for this we have purchased a wood sheet having size 2*1.6 m². And then making a base having length 1.5 m, width-1.2 m, height- 20 cm by cutting, drilling, fixing, filing , etc operations.



Figure 4.34: Construction of Frame

After completing base our next task was to join the ALUMINUM EXTRUSION TRACKS (having cross section 20*40 mm) on the sides of wooden base, for mounting that tracks we faced different problems like (1) joining these tracks without disturbing the wheels motion which are going to run on it, (2) the another problem was that the tracks we got from market were in pieces (ie. We have a need of 1.5 m long extrusion but we had it in two pieces of 1000mm +500mm)and we have to join them for making a single track without forming of any obstacle to the wheel while moving.



Figure 4.35: Placing of Aluminum Extrusions

We solved these problems by making different brackets having different shapes and size as per our requirements, so we design the brackets as per need. Initially we decided to make these brackets by using ALUMINUM material for its light weight but after lot of discussion and need of those brackets in project we decided to use WOOD as a material for making brackets and this decision gave us many benefits in whole manufacturing such as, it reduced the material cost , it provided flexibility in designing as per our need also it became easy to machine it, etc.



Figure 4.36: Making of Wooden Brackets

After making brackets we mounted the extrusion tracks on sides of base by using nut and bolts, initially we joined wooden brackets on the base at proper positions that we decided so that upper holes on brackets can easily come in mesh with the holes that we were drilled on sides of extrusion and then by using nut and bolt we fixed the tracks on base at some height. For joining tracks we also assembled two piece track into single one by adding a 5 mm nut in between holes of tracks by tightening so that they can be fixed.

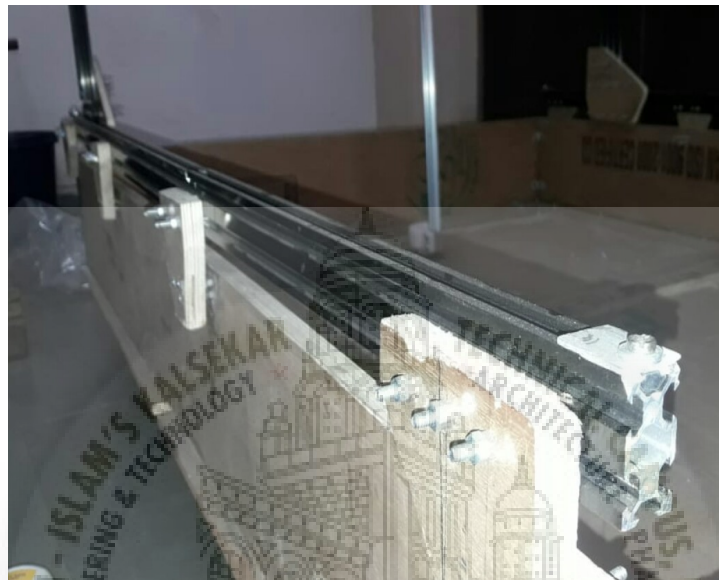

Figure 4.37: Placing of Wooden Brackets

Then we joined 4 Caster wheels from the bottom side of base for moving whole assembly from one place to another place.



Figure 4.38: Mounting of Castor Wheels

After mounting tracks on base we went forward to mount the GANTRY COLUMN (X-axis motion) on that tracks and we also needed a motion in between tracks

and gantry column for performing operation i.e. our column had to run on the tracks in forward and backward direction for getting required movements . So we made two plates for both sides, again by using wood as material and we drilled different holes on exact location by proper measurement for joining V-WHEELS on it so that its alignment will be exactly as per our need . We carefully designed and fabricate these plates because we had to mount wheels on it and these wheels were going to move on track for getting motion and bottom wheel's are needed for support and little changes in position may have caused many problems while moving. After the wheel's mounting we fixed GANTRY COLUMN (cross section 20*60mm) vertically on the upper side holes on that plate .



Figure 4.39: Mounting of Gantry Column

After mounting columns on track we mounted a brackets on the upper side of column, These brackets are for joining the HORIZONTAL BEAM (cross section 20*60) and for mounting of NEMA 17 STEPPER MOTOR. Once these brackets were joined by using nut (5mm dia) and bolts we connected horizontal beam to these brackets, on which cross slide will move for getting y- axis movement of tool.



Figure 4.40: Mounting of brackets on top of column extrusion

Before permanently fixing horizontal beam on brackets we made a cross slide of wood. this cross slide use for y axis motion. For making this cross slide we made its sketch as per need and according to that sketch we performed cutting, drilling, filing operations on it for making it. As moving wheels were to be mounted on it we checked a proper alignment . We also reduced thickness of small portion of it for mounting stepper motor , also we joined a LEAD screw block on its side which holds and allows the lead screw motion and on same side wheels were mounted which are required for vertical extrusion and through which it get Z-axis movement .once making of cross slide completed we mount it on horizontal beam and then permanently fix the horizontal beam on side brackets of column.

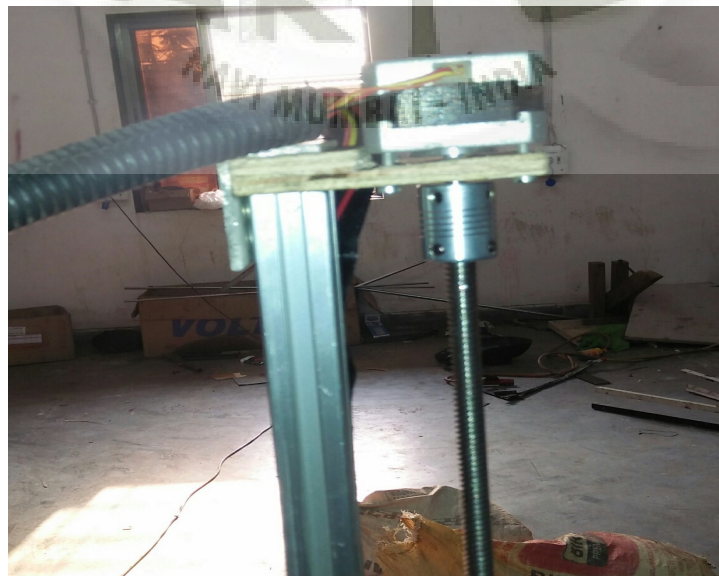

Figure 4.41: Making and mounting of Cross Slide

Then we join brackets on the upper side of Z-axis vertical extrusion for mounting stepper motor, then vertical extrusion mount on the cross slides through a wheels for getting z-axis motion. Then NEMA 17 Stepper motor mounted on the vertical extrusion in such a way that shaft of the motor was facing downwards. 5mm to 8 mm flexible coupling were mounted on motor shaft and from other end lead screw were inserted which is further passed from lead screw block mounted on the cross slide.



Figure 4.42: Mounting of brackets and coupling to hold motor and lead screw

Our next task was to make a universal tool and for this we design a tool on 3D software as per our need and using 3D printing technology we form a tool mount. Then by using T-NUTS we mounted this tool at the bottom side of vertical extrusion. and at the extreme bottom of vertical extrusion we joined a GRIPPER which perform harvesting operation.



Figure 4.43: Making and Mounting of Universal Tool

After completion of this, we mounted one Nema 17 stepper motor each on both sides brackets on the upper side of Gantry column for x-axis direction and one Nema 17 stepper motor on cross slide for getting Y -axis direction. After all motors were mounted GT2 pulley were mounted on the motor shafts. Then we engaged the GT2 timing belts of X -AXIS direction, for that GT2 timing belt is engaged with pulley teeth and allowed to pass through the opening in the GANTRY column extrusion . The belt coming out from the lower end Gantry column were feed under the V-wheels and both ends of belt fixed at both the extreme end of the track extrusion. Similarly for Y -AXIS direction , GT2 timing belt were fixed at both the end of the gantry beam extrusion and then it is allowed to passed through the V-wheels of the cross slide and finally engaged it with the teeth of GT2 pulley mounted on the shaft of NEMA-17 stepper motor of cross slide.



Figure 4.44: Placing of GT2 Timing Belt

Then we made STOPPER using aluminum plate for avoiding the extra movement of Gantry column or v-wheel's and joined it at extreme ends of the track's so that gantry should not be move out of track in any case.



Figure 4.45: Mounting of Stopper Plate

Then we made a tray for holding seeds using a metal sheet and by using bolts, mounted it on the plate at the lower side of gantry column on the same nuts by which we mounted wheels earlier.

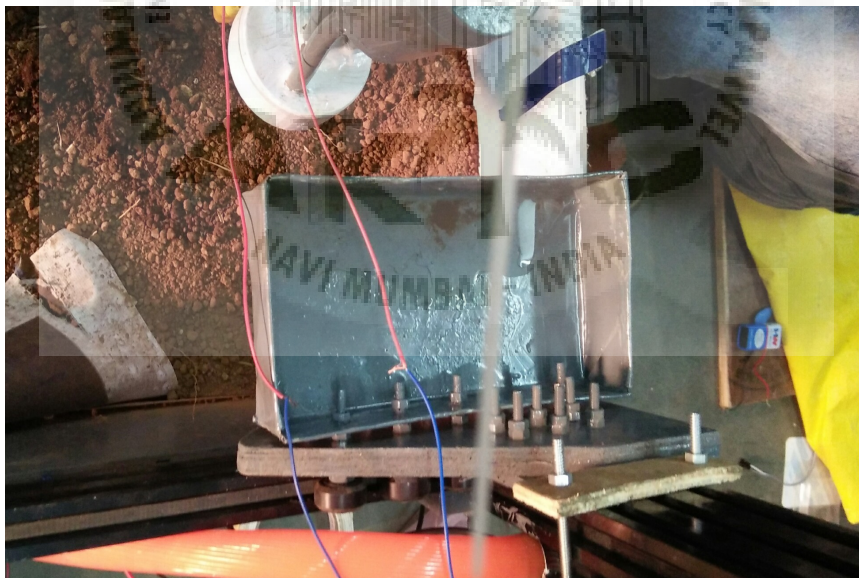

Figure 4.46: Making and Mounting of Seed Holding Tray

After that we assembled 2 plastic boxes on frame, one on gantry column (WIRING) also called as Farm-Dino and other on side of wooden base in which power supply were kept.



Figure 4.47: Placing of Farm-Dino and Power Supply Box

Then we made one more bracket called as peripheral Mount for holding the Vacuum pump and mount this bracket on the vertical extrusion and then on that bracket Vacuum pump were mounted using zip lock and then we connected the outlet of vacuum pump to the universal tool by pipeline.



Figure 4.48: Placing of Peripheral Mount for Carrying Vacuum pump

After that we mounted a WATER PUMP on the gantry column and its outlet gives to universal tool mount and its inlet were connected with reservoir.

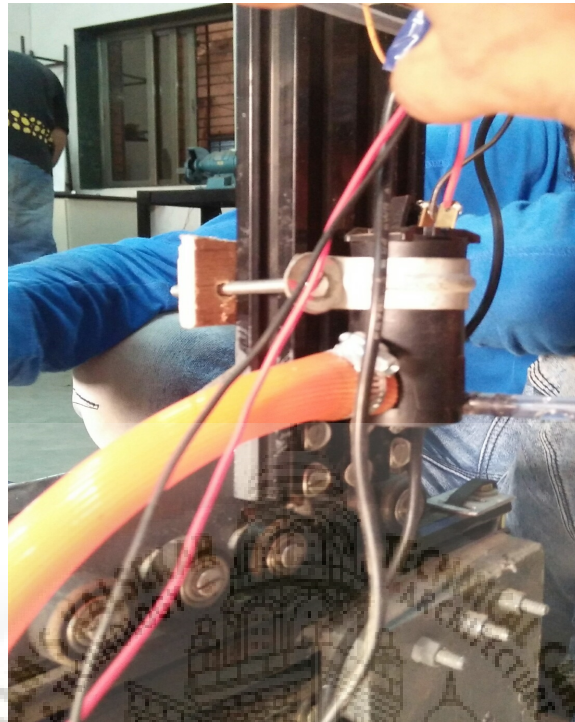

Figure 4.49: Mounting of Water Pump

Finally we completed fabrication part of our Farm-Bot with painting and by joining power switch and electric extension at the side of base.

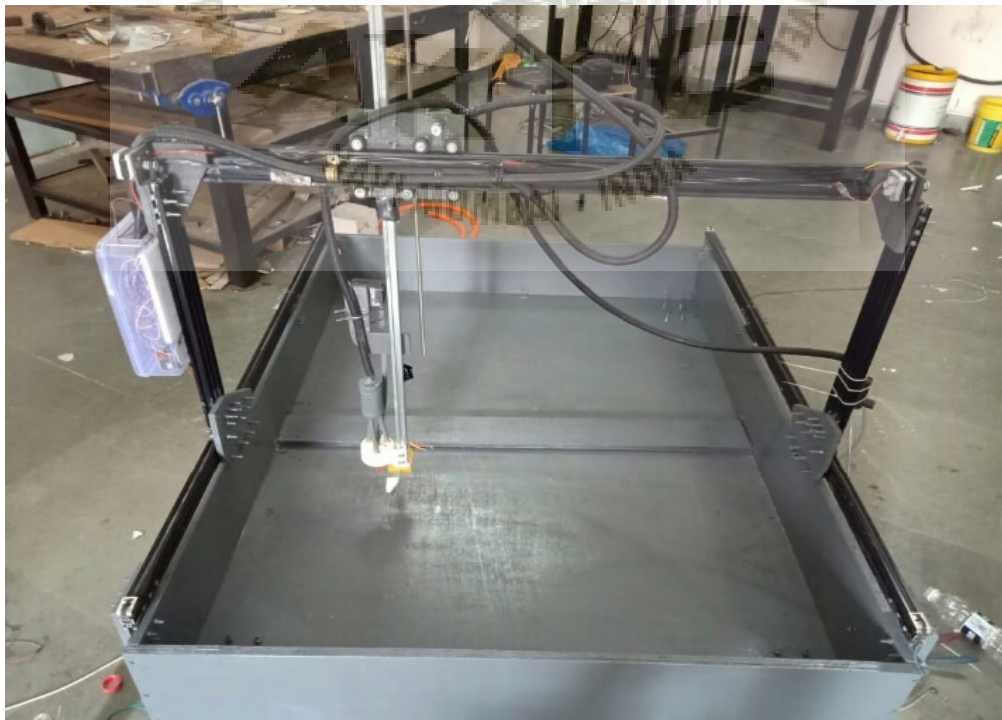

Figure 4.50: Final Structure Assembly of Farm-Bot

4.2.3 Working Motions of Farm-Bot

In all there are three motions takes place in Farmbot.

1. X-Axis Direction

It is obtain by the movement of Gantry on the track extrusion. We have two NEMA-17 stepper motor mounted on top right and top left of the gantry.

GT2 pulley is mounted on the motor shaft, GT2 timing belt is engaged with the pulley teeth and is allowed to pass through the openings in the gantry column extrusion. The timing belt coming out from the lower end of the gantry column is feed under the V-wheels and then both the end of the belt is fixed at both the extreme end of the track extrusion.

So as when the motor rotates clock wise and anti-clockwise we get the forward and backward motion respectively.



Figure 4.51: X-Axis Motion From Stepper Motor to Timing Belt



Figure 4.52: X-Axis Motion From Timing Belt to V-Wheels

2. Y-Axis Direction

It is obtain by the movement of cross slide on gantry beam.

At first GT2 timing belt is fixed at both the end of the gantry beam extrusion and then it is allowed to passed through the V-wheels of the cross slide and finally engages it with the teeth of GT2 pulley mounted on the shaft of NEMA-17 stepper motor of cross slide.

So as when the motor rotates clock wise and anti-clockwise we get the rightward and leftward motion respectively.

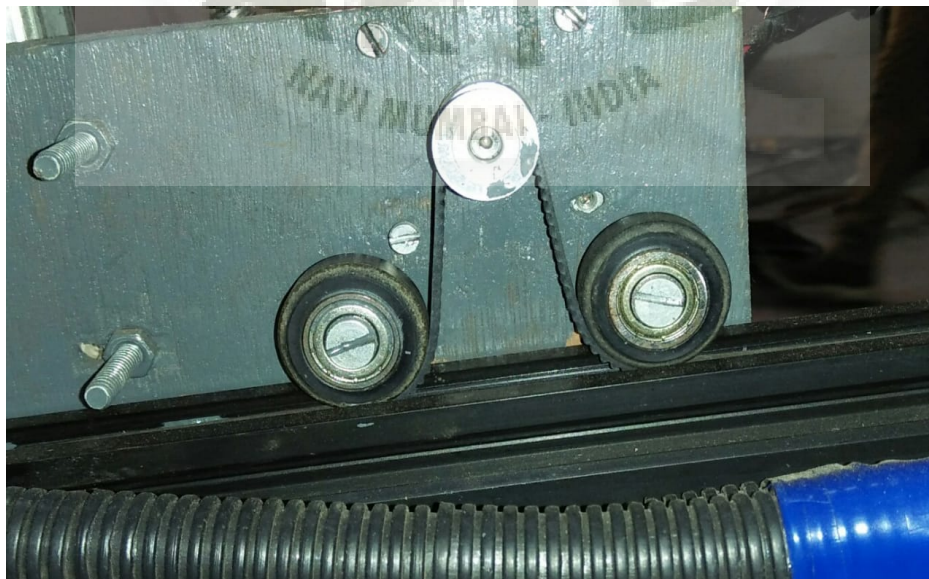

Figure 4.53: Y-Axis Motion From Stepper Motor-Timing Belt-V-Wheels

3. Z-Axis Direction

it is obtain by the vertical movement of z-axis extrusion.

NEMA-17 stepper motor is mounted on the top of the vertical extrusion in such a way that the shaft of the motor is facing downward.

5mm to 8mm Flexible coupling is mounted on the shaft of that motor and from other end lead screw is inserted which is further passed from lead block mounted on the cross slide.

So as when the motor rotates clock wise and anti-clockwise we get the upward and downward motion respectively.



Figure 4.54: Z-Axis Motion From Stepper Motor-Flexible Coupling-Lead Screw

Chapter 5

Automation/Programming

5.1 Overview

Farm-bot is a multifunction Robot that performs three major functions normally required in Agriculture field i.e. Ploughing and Seed distribution, Watering and Agriculture Harvesting. These things are interfaced with Arduino Mega 2560, NEMA 17 stepper motors. The three-axis machine employs linear guides in the X, Y, and Z directions, which allows for tooling such as seed injectors, watering nozzles, sensors, and weed removal equipment to be accurately positioned.

5.2 Basic Components used for Programming

There are number of electronic components used for Producing combined effect of Programming which in turns automates the whole system and produce desired output.

1. Power Supply :- Power Supply unit (PHOENIX CONTACT) is the main supply for whole Programming unit. it takes 240V, 9A electric supply and gives 24V, 5A as output supply which can be given to other Electronic components. this is done in order to avoid fluctuations in Electric supply and to prevent other equipment's from damage.

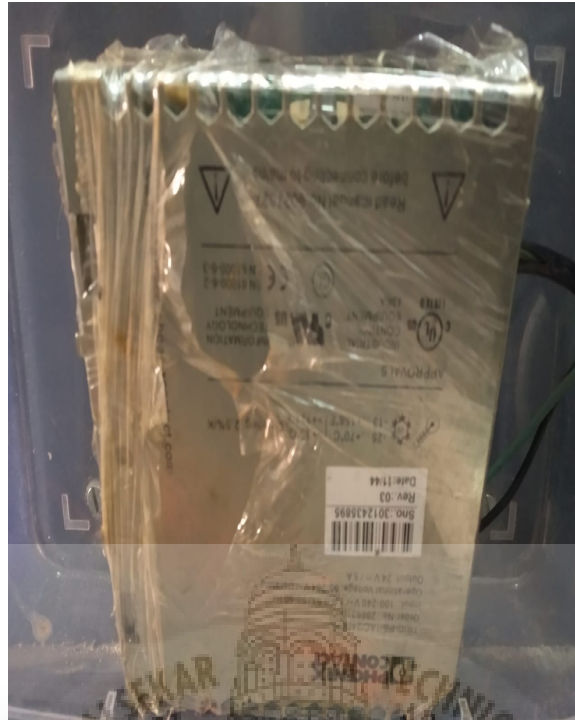

Figure 5.1: Power Supply Unit

Specifications:-

- Input:- 240V-/1.9.0 9A/ 50-60Hz
- Output:- 24V-/ 5A

2. Arduino Mega 2560:- Arduino MEGA 2560 is a micro-controller which get command from its interface application and then it run motors, vacuum pump, water pump, mechanical gripper, soil sensor and more.

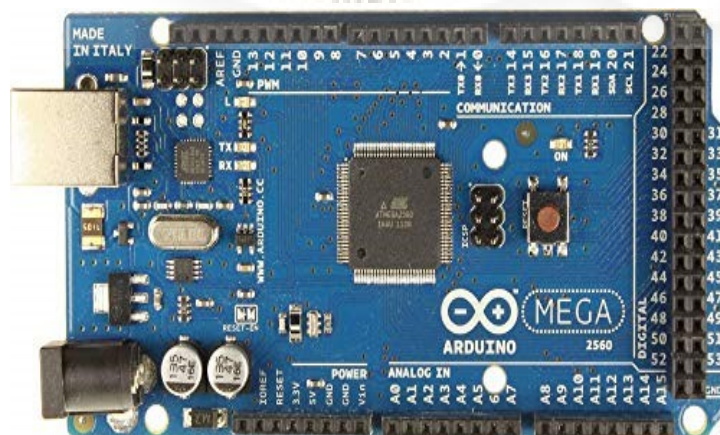

Figure 5.2: Arduino Mega 2560

Specifications:-

- Input:- 24v
- Clock Speed:- 16 MHz

3. Stepper Driver (x4):- These drivers convert step and direction signals from the micro-controller into powerful electrical pulses sent to the NEMA 17 stepper motors to allow them to move. All of the stepper drivers have been mounted and tested on Arduino MEGA 2560.

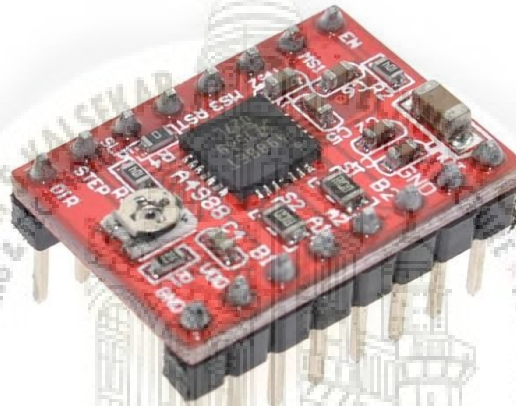

Figure 5.3: Stepper Motor Driver

Specifications:-

- Input Voltage:- 8–35v
- Output Voltage:- 3.3-5v
- A4988 stepper motor driver

4. Servo Driver:- This driver get signals from micro controller and convert it into powerful electrical pulses and send it to the mechanical gripper to perform the desired operation.

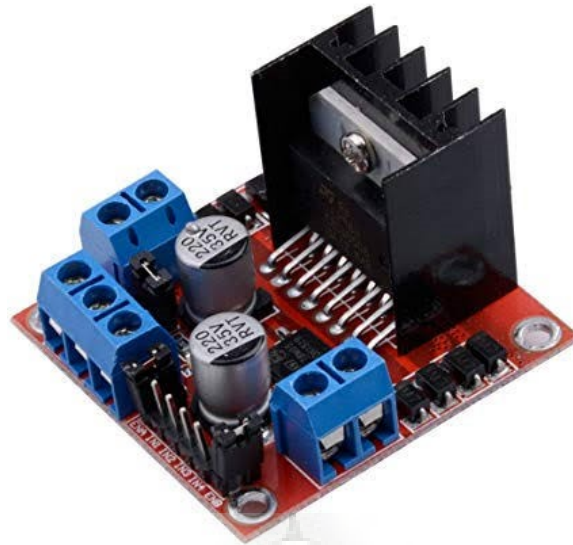

Figure 5.4: Servo Driver

Specifications:-

- Input Voltage:- 9v Battery supply.
- L2988 Servo driver.

5. Relay Module (x2):- It is used to control both vacuum pump as well as water pump, it take signal from micro-controller and send electrical pulses to both the pumps.



Figure 5.5: Relay Module

Specifications:-

- Input Voltage:- 12v

6. NEMA 17 Stepper motor:- It obtain signals from micro-controller and performs the X, Y and Z movement of gantry.

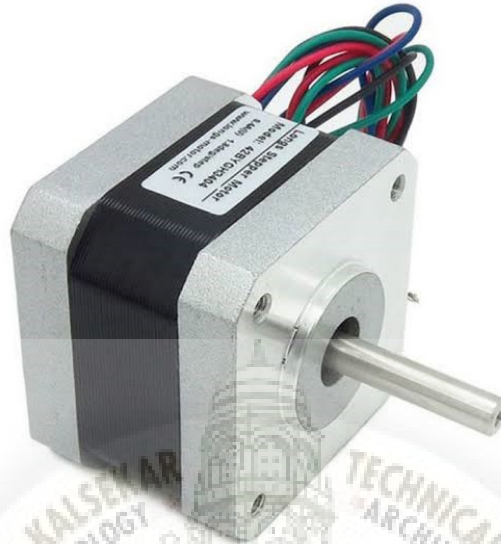

Figure 5.6: Nema 17 Stepper Motor

Specifications:-

- Input Voltage:- 12v
- Current Draw:- 1.3Amp
- Carrying Capacity:- 4Kg
- Shaft Diameter:- 5mm

7. Soil sensor:- The Soil Sensor is basically a variable resistor having two exposed pads which function as probes for the sensor, the more water in the soil the better conductivity between the pads which will result in lower resistance and the it sends a signal to a buzzer mounted for the indication purpose.

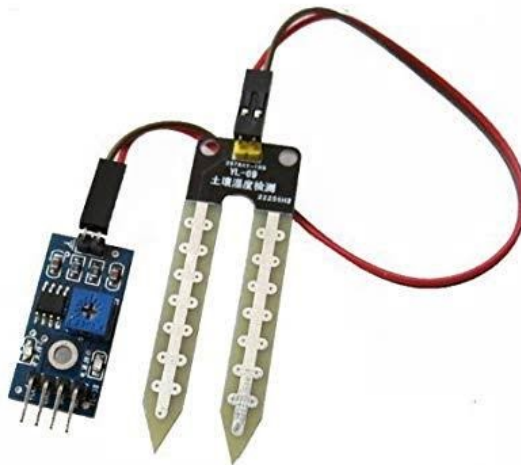

Figure 5.7: Soil Sensor

Specifications:-

- Input Voltage:- 12v

8. Water Pump:- It is connected to the micro-controller along with 2 Relay module, as it get the signal from the micro-controller it pumps out the water through the watering tool on the farming bed to perform watering operation.



Figure 5.8: Water Pump

Specifications:-

- Input Voltage:- 12v DC
- Operating Current:- 0.1A- 1.5A
- Flow rate:- 300L/Hr

9. Vacuum Pump:- The vacuum pump sucks the seeds through the seeder nozzle in order to suction-hold a seed during the seeding operation.



Figure 5.9: Vacuum Pump

Specifications:-

- Input Voltage:- 12v DC
- Operating Current:- 0.5A
- Flow rate:- 5L/min
- Max Pressure:- 80 KPa

10. Mechanical Gripper:- Mechanical gripper runs with the help of servo motor which is controlled by microcontroller through L2988 servo driver and is use to grab and remove the grown up plant during the harvesting operation.



Figure 5.10: Mechanical Gripper

Specifications:-

- Input Voltage:- 9-12v

5.2.1 Wiring Diagram

Power supply is used to run four stepper motor via driver pins v_{mot} where v_{mot} are given to + of power supply and ground is connected to negative of power supply. In a single motor there are 4 pins and they are all connected to driver pins 2b 2a 1a 1b simultaneously. From which the two motors are connected to their drivers making a pair of 2b 2a 1a 1b these motors are used for running at x axis motion y axis and z axis are having separate drivers and separate pins. Drivers used are a4988. Arduino mega 2560 is used where its + is given to v_{dd} of all the 4 drivers and - is given to ground of all the four drivers

Arduino pin 2 is given to pin vcc of water pump relay and pin 3 is given to driver 1 and 2 of pin step, and pin 4 is given to driver 1 and 2 of pin direction.

Arduino pin 5 is given to driver 3 to pin step.

Arduino pin 6 is given to driver 3 to pin direction.

Arduino pin 7 is given to driver 4 to pin step.

Arduino pin 8 is given to driver 4 to pin direction.

Arduino pin 10 is given to in2 of vacuum pump relay.

Arduino pin 11 is given to in2 of soil sensor module.

Arduino pin 13 is given to + of buzzer and - is given to - of arduino.

Both the relays vcc are given to + arduino.

Module vcc is given to + arduino

Relays pin 'no' is given to water pump and vacuum pump and com is given to + power supply

All drivers are interconnected to pins reset and sleep

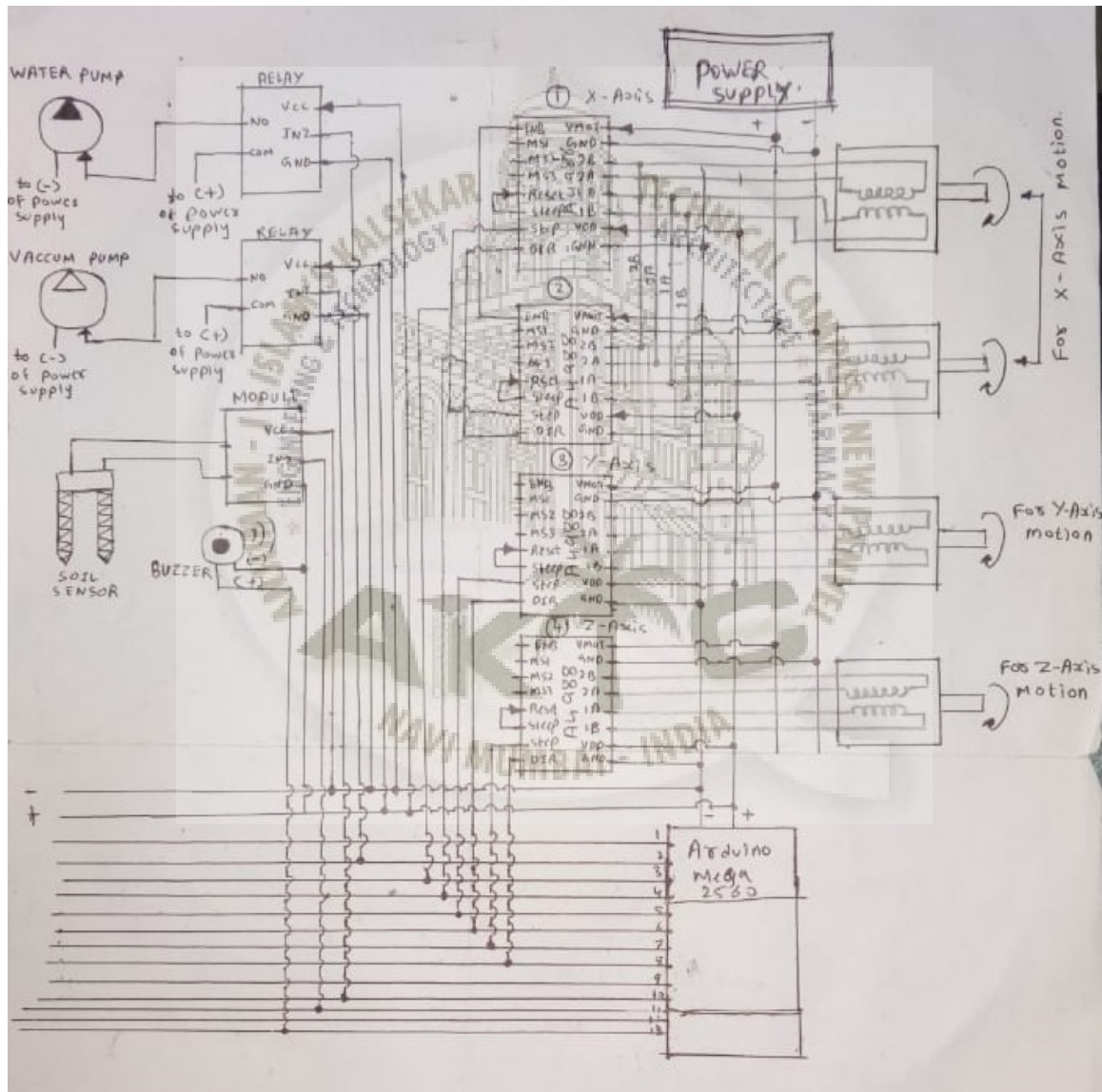

Figure 5.11: Wiring Diagram

5.2.2 Block Diagram

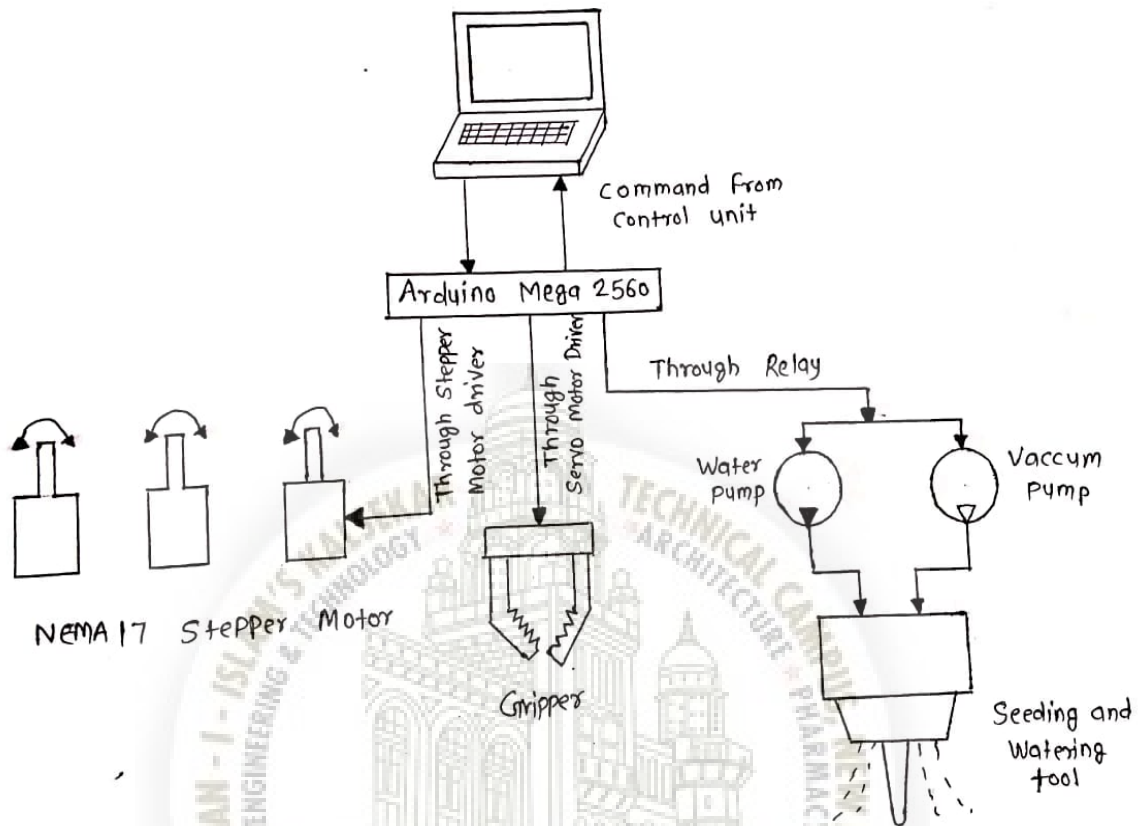

Figure 5.12: Block Diagram

Chapter 6

Implementation

6.1 Arduino Based Stepper Motor Program

```
1 f // defines pins numbers
2 const int stepPin = 3;
3 const int dirPin = 4;
4
5
6 void setup() {
7
8     // Sets the two pins as Outputs
9
10    pinMode(stepPin ,OUTPUT);
11    pinMode(dirPin ,OUTPUT);
12
13 }
14 void fn () {
15     digitalWrite(dirPin ,HIGH); // Enables the motor to move in a particular
16     // direction
17     // Makes 200 pulses for making one full cycle rotation
18     for(int x = 0; x <800; x++)
19     {
20         digitalWrite(stepPin ,HIGH);
21         delayMicroseconds(500);
22         digitalWrite(stepPin ,LOW);
23         delayMicroseconds(500);
24     }
25     digitalWrite(dirPin ,LOW); //Changes the rotations direction
26     // Makes 400 pulses for making two full cycle rotation
27     for(int x = 0; x <800; ++x)
28     {
29         digitalWrite(stepPin ,HIGH);
30         delayMicroseconds(500);
31         digitalWrite(stepPin ,LOW);
32         delayMicroseconds(500);
33     }
34
35     noInterrupts();
36     // cli();//Disable interrupts
37     delay(300);
38 }
```

6.2 Arduino Based Water Pump Program

```
1 const int pmppin = 2;
2
3
4 const int pmppin2 = 10;
5
6 void setup() {
7   pinMode(pmppin,OUTPUT);
8   pinMode(pmppin2,OUTPUT);
9
10 }
11
12 void loop() {
13   digitalWrite(pmppin,HIGH);
14
15
16   digitalWrite(pmppin,LOW);
17
18
19   digitalWrite(pmppin2,HIGH);
20
21
22   digitalWrite(pmppin2,LOW);
23
24
25 }
```



6.3 Arduino Based Vacuum Pump Program

```
1 const int pmppin = 2;
2
3
4 const int pmppin2 = 10;
5
6 void setup() {
7   pinMode(pmppin,OUTPUT);
8   pinMode(pmppin2,OUTPUT);
9
10 }
11
12 void loop() {
13   digitalWrite(pmppin,HIGH);
14
15
16   digitalWrite(pmppin,LOW);
17
18
19   digitalWrite(pmppin2,HIGH);
20
21
22   digitalWrite(pmppin2,LOW);
23
24 }
25 }
```



6.4 Arduino Based Gripper Program

```
1
2
3 void setup() {
4   // put your setup code here, to run once:
5   pinMode(2, OUTPUT);
6   pinMode(10, OUTPUT);
7   pinMode(11, OUTPUT);
8 }
9
10 void loop() {
11   // put your main code here, to run repeatedly:
12   digitalWrite(2,LOW);
13   digitalWrite(10,HIGH);
14   analogWrite(11,200);
15   delay(10);
16   digitalWrite(2,HIGH);
17   digitalWrite(10,LOW);
18   analogWrite(11,200);
19   delay(10);
20
21 }
```



6.5 Arduino Based Loop Program

```

1  const int pmppin2 =10;
2  const int pmppin =2;
3  const int stepPin = 3; //for X axis
4  const int dirPin = 4; //for X axis
5  const int stepPin2 = 5;
6  const int dirPin2 = 6;
7  const int stepPin3 = 7;
8  const int dirPin3 = 8;
9  const int EN = 9;
10 const int in3 = 11;
11 const int in4 = 12;
12 const int enb = A5;
13
14 void setup()
15 {
16
17 // Sets the two pins as Outputs
18 pinMode(pmppin ,OUTPUT);
19 pinMode(pmppin2 ,OUTPUT);
20 pinMode(stepPin ,OUTPUT);
21 pinMode(dirPin ,OUTPUT);
22 pinMode(stepPin2 ,OUTPUT);
23 pinMode(dirPin2 ,OUTPUT);
24 pinMode(stepPin3 ,OUTPUT);
25 pinMode(dirPin3 ,OUTPUT);
26 pinMode(EN, OUTPUT);
27 pinMode(in3 ,OUTPUT);
28 pinMode(in4 ,OUTPUT);
29 pinMode(enb ,OUTPUT);
30
31 }
32
33
34 void loop() {
35   digitalWrite(dirPin ,LOW); // Enables the motor to move in a particular
36     direction
37   // Makes 200 pulses for making one full cycle rotation
38   for(int x = 0; x <2400; x++)
39   {
40     digitalWrite(stepPin ,HIGH);
41     delayMicroseconds(400);
42     digitalWrite(stepPin ,LOW);
43     delayMicroseconds(400);
44   }
45   delay(30);
46   digitalWrite(EN,LOW);
47
48   digitalWrite(pmppin ,LOW);
49   digitalWrite(pmppin2 ,LOW);
50
51   digitalWrite(dirPin3 ,HIGH); // Enables the motor to move in a particular
52     direction
53   // Makes 200 pulses for making one full cycle rotation
54   for(int x = 0; x <2800; x++)
55   {
56     digitalWrite(stepPin3 ,HIGH);
57     delayMicroseconds(400);
58     digitalWrite(stepPin3 ,LOW);
59     delayMicroseconds(400);

```

```
58 }
59     delay(30);
60
61     digitalWrite(dirPin2 ,LOW); //Changes the rotations direction
62     // Makes 400 pulses for making two full cycle rotation
63     for(int x = 0; x <1200; x++)
64     {
65         digitalWrite(stepPin2 ,HIGH);
66         delayMicroseconds(400);
67         digitalWrite(stepPin2 ,LOW);
68         delayMicroseconds(400);
69     }
70     delay(30);
71
72     digitalWrite(dirPin3 ,LOW); // Enables the motor to move in a particular
73         direction
74     // Makes 200 pulses for making one full cycle rotation
75     for(int x = 0; x <8800; ++x)
76     {
77         digitalWrite(stepPin3 ,HIGH);
78         delayMicroseconds(400);
79         digitalWrite(stepPin3 ,LOW);
80         delayMicroseconds(400);
81     }
82     delay(30);
83
84     digitalWrite(pmppin ,HIGH);
85     delay(500);
86
87     digitalWrite(dirPin3 ,HIGH); // Enables the motor to move in a particular
88         direction
89     // Makes 200 pulses for making one full cycle rotation
90     for(int x = 0; x <7200; x++)
91     {
92         digitalWrite(stepPin3 ,HIGH);
93         delayMicroseconds(400);
94         digitalWrite(stepPin3 ,LOW);
95         delayMicroseconds(400);
96     }
97     delay(30);
98
99     digitalWrite(dirPin2 ,HIGH); //Changes the rotations direction
100     // Makes 400 pulses for making two full cycle rotation
101     for(int x = 0; x <1200; ++x)
102     {
103         digitalWrite(stepPin2 ,HIGH);
104         delayMicroseconds(400);
105         digitalWrite(stepPin2 ,LOW);
106         delayMicroseconds(400);
107     }
108     delay(50);
109
110     digitalWrite(pmppin ,LOW);
111     delay(500);
112
113     digitalWrite(dirPin3 ,LOW); // Enables the motor to move in a particular
114         direction
115     // Makes 200 pulses for making one full cycle rotation
116     for(int x = 0; x <400; x++)
117     {
118         digitalWrite(stepPin3 ,HIGH);
```



```
116     delayMicroseconds(400);
117     digitalWrite(stepPin3 ,LOW);
118     delayMicroseconds(400);
119 }
120     delay(400);
121
122     digitalWrite(dirPin3 ,HIGH); // Enables the motor to move in a particular
123     direction
124 // Makes 200 pulses for making one full cycle rotation
125 for(int x = 0; x <800; x++)
126 {
127     digitalWrite(stepPin3 ,HIGH);
128     delayMicroseconds(400);
129     digitalWrite(stepPin3 ,LOW);
130     delayMicroseconds(400);
131 }
132     delay(30);
133
134     digitalWrite(dirPin2 ,LOW); //Changes the rotations direction
135 // Makes 400 pulses for making two full cycle rotation
136 for(int x = 0; x <2800; x++)
137 {
138     digitalWrite(stepPin2 ,HIGH);
139     delayMicroseconds(400);
140     digitalWrite(stepPin2 ,LOW);
141     delayMicroseconds(400);
142 }
143     delay(30);
144
145     digitalWrite(dirPin3 ,LOW); // Enables the motor to move in a particular
146     direction
147 // Makes 200 pulses for making one full cycle rotation
148 for(int x = 0; x <9200; ++x)
149 {
150     digitalWrite(stepPin3 ,HIGH);
151     delayMicroseconds(400);
152     digitalWrite(stepPin3 ,LOW);
153     delayMicroseconds(400);
154 }
155     delay(30);
156
157     digitalWrite(pmpin ,HIGH);
158     delay(500);
159     digitalWrite(pmpin2 ,LOW);
160
161     digitalWrite(dirPin3 ,HIGH); // Enables the motor to move in a particular
162     direction
163 // Makes 200 pulses for making one full cycle rotation
164 for(int x = 0; x <8400; x++)
165 {
166     digitalWrite(stepPin3 ,HIGH);
167     delayMicroseconds(400);
168     digitalWrite(stepPin3 ,LOW);
169     delayMicroseconds(400);
170 }
171     delay(30);
172
173     digitalWrite(dirPin2 ,HIGH); //Changes the rotations direction
174 // Makes 400 pulses for making two full cycle rotation
175 for(int x = 0; x <2800; ++x)
176 {
```

```
174     digitalWrite (stepPin2 ,HIGH);
175     delayMicroseconds (400);
176     digitalWrite (stepPin2 ,LOW);
177     delayMicroseconds (400);
178 }
179     delay (30);
180
181     digitalWrite (pmpin ,LOW);
182     delay (500);
183
184     digitalWrite (dirPin3 ,LOW); // Enables the motor to move in a particular
185     direction
186 // Makes 200 pulses for making one full cycle rotation
187 for (int x = 0; x <800; ++x)
188 {
189     digitalWrite (stepPin3 ,HIGH);
190     delayMicroseconds (400);
191     digitalWrite (stepPin3 ,LOW);
192     delayMicroseconds (400);
193 }
194     delay (400);
195
196     digitalWrite (dirPin3 ,HIGH); // Enables the motor to move in a particular
197     direction
198 // Makes 200 pulses for making one full cycle rotation
199 for (int x = 0; x <800; x++)
200 {
201     digitalWrite (stepPin3 ,HIGH);
202     delayMicroseconds (400);
203     digitalWrite (stepPin3 ,LOW);
204     delayMicroseconds (400);
205 }
206     delay (30);
207
208     digitalWrite (dirPin2 ,LOW); //Changes the rotations direction
209 // Makes 400 pulses for making two full cycle rotation
210 for (int x = 0; x <3600; x++)
211 {
212     digitalWrite (stepPin2 ,HIGH);
213     delayMicroseconds (400);
214     digitalWrite (stepPin2 ,LOW);
215     delayMicroseconds (400);
216 }
217     delay (30);
218
219     digitalWrite (dirPin3 ,LOW); // Enables the motor to move in a particular
220     direction
221 // Makes 200 pulses for making one full cycle rotation
222 for (int x = 0; x <9200; ++x)
223 {
224     digitalWrite (stepPin3 ,HIGH);
225     delayMicroseconds (400);
226     digitalWrite (stepPin3 ,LOW);
227     delayMicroseconds (400);
228 }
229     delay (30);
230
231     digitalWrite (pmpin ,HIGH);
232     delay (500);
```

```
231     digitalWrite(dirPin3 ,HIGH); // Enables the motor to move in a particular
        direction
232 // Makes 200 pulses for making one full cycle rotation
233 for(int x = 0; x <8400; x++)
234 {
235     digitalWrite(stepPin3 ,HIGH);
236     delayMicroseconds(400);
237     digitalWrite(stepPin3 ,LOW);
238     delayMicroseconds(400);
239 }
240     delay(30);
241
242     digitalWrite(dirPin2 ,HIGH); //Changes the rotations direction
243 // Makes 400 pulses for making two full cycle rotation
244 for(int x = 0; x <3600; ++x)
245 {
246     digitalWrite(stepPin2 ,HIGH);
247     delayMicroseconds(400);
248     digitalWrite(stepPin2 ,LOW);
249     delayMicroseconds(400);
250 }
251     delay(400);
252
253     digitalWrite(pmppin ,LOW);
254     delay(400);
255
256     digitalWrite(dirPin3 ,LOW); // Enables the motor to move in a particular
        direction
257 // Makes 200 pulses for making one full cycle rotation
258 for(int x = 0; x <800; ++x)
259 {
260     digitalWrite(stepPin3 ,HIGH);
261     delayMicroseconds(400);
262     digitalWrite(stepPin3 ,LOW);
263     delayMicroseconds(400);
264 }
265     delay(30);
266
267     digitalWrite(dirPin3 ,HIGH); // Enables the motor to move in a particular
        direction
268 // Makes 200 pulses for making one full cycle rotation
269 for(int x = 0; x <800; x++)
270 {
271     digitalWrite(stepPin3 ,HIGH);
272     delayMicroseconds(400);
273     digitalWrite(stepPin3 ,LOW);
274     delayMicroseconds(400);
275 }
276     delay(30);
277
278     digitalWrite(dirPin2 ,LOW); //Changes the rotations direction
279 // Makes 400 pulses for making two full cycle rotation
280 for(int x = 0; x <4800; x++)
281 {
282     digitalWrite(stepPin2 ,HIGH);
283     delayMicroseconds(400);
284     digitalWrite(stepPin2 ,LOW);
285     delayMicroseconds(400);
286 }
287     delay(30);
288
```

```
289     digitalWrite(dirPin3 ,LOW); // Enables the motor to move in a particular
        direction
290 // Makes 200 pulses for making one full cycle rotation
291 for(int x = 0; x <9200; ++x)
292 {
293     digitalWrite(stepPin3 ,HIGH);
294     delayMicroseconds(400);
295     digitalWrite(stepPin3 ,LOW);
296     delayMicroseconds(400);
297 }
298     delay(30);
299
300     digitalWrite(pmppin ,HIGH);
301
302     digitalWrite(dirPin3 ,HIGH); // Enables the motor to move in a particular
        direction
303 // Makes 200 pulses for making one full cycle rotation
304 for(int x = 0; x <8400; x++)
305 {
306     digitalWrite(stepPin3 ,HIGH);
307     delayMicroseconds(400);
308     digitalWrite(stepPin3 ,LOW);
309     delayMicroseconds(400);
310 }
311     delay(30);
312
313     digitalWrite(dirPin2 ,HIGH); //Changes the rotations direction
314 // Makes 400 pulses for making two full cycle rotation
315 for(int x = 0; x <4800; ++x)
316 {
317     digitalWrite(stepPin2 ,HIGH);
318     delayMicroseconds(400);
319     digitalWrite(stepPin2 ,LOW);
320     delayMicroseconds(400);
321 }
322     delay(100);
323
324     digitalWrite(dirPin2 ,LOW); //Changes the rotations direction
325 // Makes 400 pulses for making two full cycle rotation
326 for(int x = 0; x <6000; x++)
327 {
328     digitalWrite(stepPin2 ,HIGH);
329     delayMicroseconds(400);
330     digitalWrite(stepPin2 ,LOW);
331     delayMicroseconds(400);
332 }
333     delay(30);
334
335     digitalWrite(dirPin3 ,LOW); // Enables the motor to move in a particular
        direction
336 // Makes 200 pulses for making one full cycle rotation
337 for(int x = 0; x <9200; ++x)
338 {
339     digitalWrite(stepPin3 ,HIGH);
340     delayMicroseconds(400);
341     digitalWrite(stepPin3 ,LOW);
342     delayMicroseconds(400);
343 }
344     delay(30);
345
346     digitalWrite(11 ,LOW);
```

```
347 digitalWrite (12 ,HIGH) ;
348 analogWrite (A5,200) ;
349 delay (10) ;
350 digitalWrite (11 ,HIGH) ;
351 digitalWrite (12 ,LOW) ;
352 delay (10) ;
353
354
355     digitalWrite (dirPin3 ,HIGH) ; // Enables the motor to move in a particular
           direction
356 // Makes 200 pulses for making one full cycle rotation
357 for (int x = 0; x <8400; x++)
358 {
359     digitalWrite (stepPin3 ,HIGH) ;
360     delayMicroseconds (400) ;
361     digitalWrite (stepPin3 ,LOW) ;
362     delayMicroseconds (400) ;
363 }
364     delay (30) ;
365
366     digitalWrite (dirPin2 ,HIGH) ; //Changes the rotations direction
367 // Makes 400 pulses for making two full cycle rotation
368 for (int x = 0; x <6000; ++x)
369 {
370     digitalWrite (stepPin2 ,HIGH) ;
371     delayMicroseconds (400) ;
372     digitalWrite (stepPin2 ,LOW) ;
373     delayMicroseconds (400) ;
374 }
375     delay (100) ;
376
377     digitalWrite (dirPin2 ,LOW) ; //Changes the rotations direction
378 // Makes 400 pulses for making two full cycle rotation
379 for (int x = 0; x <1200; x++)
380 {
381     digitalWrite (stepPin2 ,HIGH) ;
382     delayMicroseconds (400) ;
383     digitalWrite (stepPin2 ,LOW) ;
384     delayMicroseconds (400) ;
385 }
386     delay (300) ;
387
388     digitalWrite (pmppin2 ,HIGH) ;
389     delay (500) ;
390     digitalWrite (pmppin2 ,LOW) ;
391     delay (500) ;
392
393     digitalWrite (dirPin2 ,LOW) ; //Changes the rotations direction
394 // Makes 400 pulses for making two full cycle rotation
395 for (int x = 0; x <2400; x++)
396 {
397     digitalWrite (stepPin2 ,HIGH) ;
398     delayMicroseconds (400) ;
399     digitalWrite (stepPin2 ,LOW) ;
400     delayMicroseconds (400) ;
401 }
402     delay (300) ;
403
404     digitalWrite (pmppin2 ,HIGH) ;
405     delay (500) ;
406     digitalWrite (pmppin2 ,LOW) ;
```

```
407
408
409     digitalWrite(dirPin2,LOW); //Changes the rotations direction
410     // Makes 400 pulses for making two full cycle rotation
411     for(int x = 0; x <3600; x++)
412     {
413         digitalWrite(stepPin2 ,HIGH);
414         delayMicroseconds(400);
415         digitalWrite(stepPin2 ,LOW);
416         delayMicroseconds(400);
417     }
418     delay(300);
419
420     digitalWrite(pmpin2 ,HIGH);
421     delay(500);
422     digitalWrite(pmpin2 ,LOW);
423
424 digitalWrite(dirPin2 ,HIGH); //Changes the rotations direction
425 // Makes 400 pulses for making two full cycle rotation
426 for(int x = 0; x <7200; x++)
427 {
428     digitalWrite(stepPin2 ,HIGH);
429     delayMicroseconds(400);
430     digitalWrite(stepPin2 ,LOW);
431     delayMicroseconds(400);
432 }
433     delay(300);
434
435
436
437
438 }
```



Chapter 7

Results and Discussion

The designed and fabricated Farm-Bot is programmed with Arduino Mega 2560 to perform operations such as Seed Sowing, Watering and Harvesting.

7.1 Expected Outcome Result

Three major functions that needs to be done are Seeding, watering and harvesting as per our project planning. We had planned to use this Farm-Bot for Poly-crop farming, that is growing different crops at same place.

7.2 Actual Outcome Result

As per our Expectation, Farm-Bot is performing well in all three Fields such as Seeding, Watering and Harvesting/cultivate plants.



Figure 7.1: Seeding Operation (Taking seed from seed tray)



Figure 7.2: Seeding Operation (digging of seed in soil)



Figure 7.3: Watering Operation



Figure 7.4: Harvesting Operation

As of now we are dealing with single crop only that is sprouts.

7.3 Technical Review

Our Project Farm-Bot are working well as per our expectation. From Picking up of seed from seed tray to digging seed into the soil in a pre-determined position. Watering can be also done at control amount and cultivating the crop, all operations are performed in a systematic way.

Chapter 8

Cost Estimation of Project

Table 8.1: Table of Cost Estimation

SR. No	Parts and Components	Quantity	Cost	Total Cost
1	Gantry column extrusion (20*60*500mm long)	2	800	1600
2	Gantry Beam extrusion (20*60*1000mm long)	1	1550	1550
3	Gantry Beam extrusion (20*60*500mm long)	1	800	800
4	Track extrusion (20*40*500 mm long)	2	900	1800
5	Track extrusion (20*40*1000 mm long)	2	1250	2500
6	Z-Axis Extrusion (20*20*1000 mm long)	1	1000	1000
7	Arduino mega 2560	1	750	750
8	Adapters (5 volts, 1 amp)	2	120	240
9	Jumper wires	100	3	300
10	Power supply (24 volt ,5amp)	1	500	500
11	Nema 17 stepper motor	4	550	2200
12	Timing belt (5mm width, 6 meters long)	1	250	250
13	Breadboard (830 point solderless)	2	70	140
14	Motor drivers A4988	4	140	560
15	Gripper claw	1	750	750
16	Lead screw block (8mm dia,2mm pitch)	2	250	500
17	Flexible coupling (5 to 8 mm)	1	250	250
18	Lead screw with Acme thread (8mm dia, 2mm pitch,800mm long)	1	850	850
19	GT2 Timing pulley (20 teeth,5mm dia)	3	150	450
20	V-Wheels (24*16*10.23mm)	30	75	2250
21	Vacuum air pump (12 volt)	1	1440	1440
22	Mini Water pump (9 volt)	1	550	550
23	Castor wheels (4inch)	4	150	600
24	2 Channel Relay module	2	120	240
25	L298 Module	1	200	200
26	PCB	1	45	45
27	Soil sensor	1	60	60
28	3 Wire cable (5 meter)	1	30/m	150
29	General Purpose Battery	2	20	40
30	2 wire cable (4meter)	1	20/m	80

SR. No	Parts and Components	Quantity	Cost	Total Cost
31	Water and Vacuum pump tubes (4meter)	1	10/m	40
32	Insulation tube (5 meter)	1	10/m	50
33	Plastic box	2	70	140
34	Extension board	1	160	160
35	Switch box	1	130	130
36	UTM Tool (3D Printed)	1	600	600
37	Tee Nuts	30	10	300
38	Plywood (1.8 m2)	2	750	1500
39	Plywood's screw	20	3	60
40	Fasteners	500	1.5	750
41	Miscellaneous	-	-	4000
=	Total	-	-	30,375



Chapter 9

Conclusion and Future Scope

9.1 Conclusion

This Project is made with pre planning, that it provides flexibility in operation. This innovation has made the more desirable and economical. This Project "Design and fabrication of Arduino Based Farm-Bot for Precision Farming" is designed with the hope that it is very much economical and help full to agriculture fields. While Working on project we interacts with new technologies such as 3D Printing, Arduino Programming and gets as much as knowledge we can. This Project helped us to know the Periodic steps in completing a project work. Thus we have completed the project Successfully.

9.2 Future Scope

There is still much future scope for improving and upgrading the Farm-Bot.

- More Sensors have to be implemented to make the system more accurate. such as camera sensor to know the exact location of crops.
- GSM/WiFi Technology have to be implemented in order to have full access of Farm-Bot on Your Device such as Mobile phones, Laptops etc.
- Plant Nutrition Database have to be update for different crops in order to grow crops more effectively by the person who doesn't have much idea about plant nutritional system.
- Large scale farming by Farm-Bot is yet to be done.

References

- [1] PRECISION-FARMING *FARM-BOT OPEN SOURCE CNC FARMING*;
<https://farm.bot/>,
- [2] *Smart Agriculture Using IoT and WSN Based Modern Technologies* ; Nikesh Gondchawar, Dr.Kawitkar R.S.,International Journal of Innovative Research in Computer and Communication Engineering An ISO 3297: Certified Organization 4(6) (2016).
- [3] *Automated Seed Sowing Agribotusing Arduino* ;Saurabh Umalkar, Anil Karwanka: International Conference on Communication and Signal Processing, (2016).
- [4] *Robotic Agriculture*;Simon Blackmore¹, Bill Stout², Maohua Wang³,Boris Runov⁴, 5th European Conference on Precision Agriculture, Uppsala, Sweden 9-12th June 2005. Journal of Physics: Conference Series. Vol. 891. No. 1. IOP Publishing,2017
- [5] *Automation in Agriculture* ;S.S.Katariya¹, S.S.Gundal², Kanawade M.T³ and Khan Mazhar⁴, International Journal of Recent Scientific Research Research , Vol. 6, Issue 6, pp.4453-4456, June 2015.
- [6] *Enabling Agricultural Automation to Optimize Utilization of Water, Fertilizer and Insecticides by implementing Internet of Things (IoT)* ;Arindam Giri, Subrata Dutta Sarmistha Neogy, International conference of information technology, (2016).
- [7] *Multi functional Robotic Vehicle for Agriculture Application*;Mahendheran, Arunprasanna, Manickavasagam, LawrenceJustin and Parthasarathi:, African Journal of Basic and Applied Sciences 9(1) (2017), 01-06.
- [8] *Real- Time Automation and Monitoring System for Modernized Agriculture* ;Dr. VidyaDevi V., MeenaKumari G., International Journal of Review and Research in Applied Sciences and Engineering (IJRRASE) 3(1) (2013), 7-12.
- [9] *Design and Development of Precision Agriculture System Using Wireless Sensor Network* ;Nandurkar S.R., Thool V.R., Thool R.C., IEEE International Conference on Automation, Control, Energy and Systems (ACES), (2014).