

An IoT Approach Based Intrusion Detection Using Raspberry PI

B.E. Dissertation

Submitted in partial fulfillment of the requirement of

University of Mumbai

For the Degree of

Bachelor of Engineering

In

Electronics and Telecommunication Engineering

By

Momin Akibrja Shabbir

(14DET52)

Under the guidance of

Asst.Prof. Zeeshan Syed

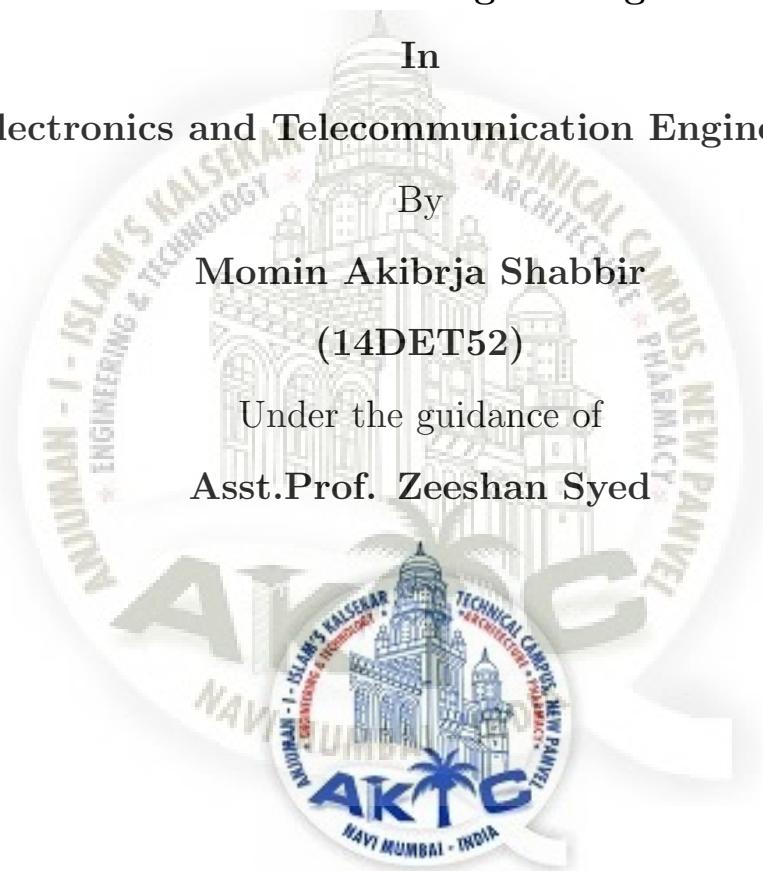

Department of Electronics and Telecommunication Engineering

Anjuman-I-Islam's Kalsekar Technical Campus,

Sector 16, New Panvel, Navi Mumbai - 410206

(Affiliated to University of Mumbai)

Academic Year: 2017-18



Anjuman-I-Islam's

Kalsekar Technical Campus

Plot No. 2 3, Sector - 16, Near Thana Naka, Khandagao, New Panvel,

Navi Mumbai, Maharashtra - 410206

CERTIFICATE

This is to certify that, the dissertation titled

“An IoT Approach Based Intrusion Detection Using Raspberry PI”

is a bonafide work done by

Momin Akibrja Shabbir (14DET52)

is submitted in the partial fulfillment of the requirement

for the degree of

Bachelor of Engineering

In

Electronics and Telecommunication Engineering

to the

University of Mumbai

Guide

Head of Department

Director

Certificate of Approval by Examiners

This is to certify that the dissertation entitled “*An IoT Approach Based Intrusion Detection Using Raspberry PI*” is a bonafide work done by *Momin Akibrja Shabbir* under the guidance of *Asst.Prof.Zeeshan Syed*. This dissertation has been approved for the award of *Bachelor’s Degree in Electronics Telecommunication Engineering, University of Mumbai*.



Examiners:

Examiner 1

Examiner 2

Acknowledgements

I have immense pleasure in expressing my thanks and a deep sense of gratitude to my guide ***Asst.Prof. Zeeshan Syed, Department of Electronics and Telecommunication Engineering, AIKTC*** for his expert guidance.

I would also like to express my deepest appreciation to my project coordinator ***Asst.Prof.Mazhar Malagi, Department of Electronics and Telecommunication Engineering, AIKTC*** for his technical support in my project.

I also express my sincere thanks to ***Prof. Afzal Shaikh, Head of the Department, AIKTC*** for extending his help.

I wish to express my profound sense of gratitude to ***Dr Abdul Razak Honnutagi, Director, AIKTC*** for his encouragement, and for all facilities to this project.

Momin Akibrja Shabbir
(14DET52)

Abstract

Recently security concerns have grown tremendously, it is important for all to be able to safeguard their property from worldly harms such as thefts, destruction of property etc. As the technology is widely growing in modern world, the methodologies used by thieves and robbers are also equally improved in stealing. Therefore, it is necessary for the surveillance techniques also to be improved with the changing world. The latest technologies used against theft and destruction are the video surveillance and monitoring. Even when needed, having a security camera system may sometimes be impossible due to the expensive cost for installation.

Raspberry pi is credit card sized computer that has the capability to become a camera security system when its own camera board is used. A new methodology has been developed to detect the motion. Pyroelectric infrared (PIR) sensors are used instead of any algorithm for motion detection. Whenever the motion is detected through PIR sensor inside the room, the image is captured through camera and temporarily stored in the raspberry pi module. After motion is detected user gets push up message on android without any delay and here python script is also used which directs the pi to send email notifications everytime motion is detected With these components, a cost effective, low power and efficient security camera system is made. Therefore, advantages like these, makes this application ideal for monitoring in prevented or secured areas.

Contents

1	Introduction	2
1.1	Objective	6
1.2	Problem Statement	6
2	Literature Survey	7
2.1	Smart surveillance and Monitoring System using Raspberry pi and Android-: Author-Priya Patel	7
2.2	An IoT Approach for Motion Detection using ARM-Based System on Chip-: Author- Adimulam Padmanabham	8
2.3	An Internet of Things (IoT) Based Security Alert System using Raspberry pi-: Author- A. Arun Raja	9
2.4	An IoT Approach for Motion Detection using Raspberry pi-: Author- Aamir Ansari	9
2.5	Smart Motion Detection System Using Raspberry Pi-: Author- Swapna Jadhav	10
2.6	Advanced Real Time Home Security System Based on Raspberry pi-: Author- Amol Boke	11
2.7	Real Time Video Monitoring System Using Raspberry Pi-: Author- Sunil Kanzariya	12

3	Proposed System	13
3.1	Methodology-:	13
3.2	Block Diagram-:	14
4	Component Details	16
4.1	Hardware-:	16
4.1.1	Raspberry Pi-:	16
4.1.2	PIR Sensor-:	18
4.1.3	Camera Module-:	21
4.2	Software-:	23
4.2.1	Putty Configuration-:	23
4.2.2	Programming-:	25
4.2.3	Detect motion using PIR sensor and Raspberry pi-: . . .	25
4.2.4	Connect PIR sensor to the pi-:	25
4.2.5	Motion Detection Program-:	27
4.2.6	Connect the Camera Module and Save images-:	29
4.2.7	Connect the Camera Module-:	29
4.2.8	Still Pictures-:	29
4.2.9	Email Notification-:	31
5	Results And Discussions	32
6	Conclusion and Future Scope	34
6.1	Conclusion	34
6.2	Future Scope	34
	References	34

List of Figures

1.1	IoT used in different fields	4
3.1	System Flow Diagram	13
3.2	Block Diagram	14
4.1	Raspberry pi 3 model B	16
4.2	Top View of PIR Sensor	18
4.3	Front View of PIR Sensor	19
4.4	How the PIR Motion Sensor Works	20
4.5	Camera Module v1	21
4.6	Putty Configuration	23
4.7	Raspberry pi PIR motion sensor connection	25
4.8	PIR Sensor Output	28
4.9	Camera Output	30
5.1	Motion detection images with time	32
5.2	Motion detection image in email	33

Chapter 1

Introduction

The Surveillance means to monitor something. Security in residential complexes is restricted to limited geographical locations due to the traditional devices and process used for securing any apartment or complexes. High Definition Surveillance Camera using raspberry pi is set up in the areas which need to be monitored. This system is motivation from other systems which explains similar systems with some disadvantages which is tried to be solved. It also includes some additional feature like data backup, push alert messages instead of SMS schemes which requires additional hardware like GSM. New technologies are included like IoT (Internet of thing) based applications. The internet of Things (IoT) is the inter networking of physical devices, buildings and other items embedded with electronics, software, sensors, actuators and network connectivity that enable these objects to collect and exchange data. It is expected that by 2020, 20 billion devices will be connected with the Internet. This system is built in general purpose and so area is not limited for the use of system and include many applications where it can be used which replace existing system. It is also user friendly as if user can access the system from remotely as well as locally as per the situation. Two different controlling android applications are provided for accessing raspberry pi through command line or GUI based.

In the present world where we live there are already devices, which are connected to each other and help in day to day aspects, for example wearable fitness devices, sensors which help in automatic garages, RFIDs in ID cards used in Universities and Industries to gain and lock access. However, imagine this after a few years where billions of devices will be connected to each other including cars, phones etc. Internet of Things(IoT) is a going development of the Internet by which every day things objects have communication capabilities which allow them to send and receive data. It is expected to connect systems, devices, sensors which can communicate without need of machine-to-machine Communication [1].

IoT refers to an enormous variety of devices such as sensors that assist fire fighters in rescue and search operations, heart beat and blood pressure measuring devices, bio-chips that are implanted in farm animals. The internet of things presently is being used in the fields of automobiles, agriculture, security surveillance, smart homes and health care. The IOT expects to use low cost computing devices where there is less energy consumption's and limited impact to the environment.

The project aims to simplify motion detection and the interface to be user friendly, which would send prompt notifications when motion is detected. The main limitation of Internet of things is that as the devices have limited computing power the security aspects come in question as the transmitted and received data cannot be encrypted and decrypted. However, Internet of things offers many advantages that overcome this disadvantage. The IOT will revolutionize everyday life and help in situations like managing airports' passenger flows, smart homes, heating buildings, caring for the elderly [2].

The IoT has its own challenges, which need to be addressed. Every device will require an IP address to communicate, the present IPv4 has only 4.3 billion unique addresses, which will be exhausted soon and hence we will need to adapt to IPv6. The next challenge would be data storage, as billions of devices are connecting the data would need to be stored for which massive storage space

tential users. From the point of view of a private user, the most obvious effects of the IoT will be visible in both working and domestic fields. In this context, assisted living, smart homes and offices, e-health, enhanced learning is only a few examples of possible application scenarios in which the new paradigm will play a leading role in the near future. Similarly, from the perspective of business users, the most apparent consequences will be equally visible in fields such as automation and industrial manufacturing, logistics, business process management, intelligent transportation of people and goods. The main aim of this project is the utilization of Raspberry Pi to depict a security alert framework utilizing low processing power chips utilizing Internet of things which screens and get alerts when movement is identified and sends photographs and recordings to a cloud server. Moreover, Internet of things (IoT) based application can be utilized remotely to see the movement and get warnings when movement is identified.

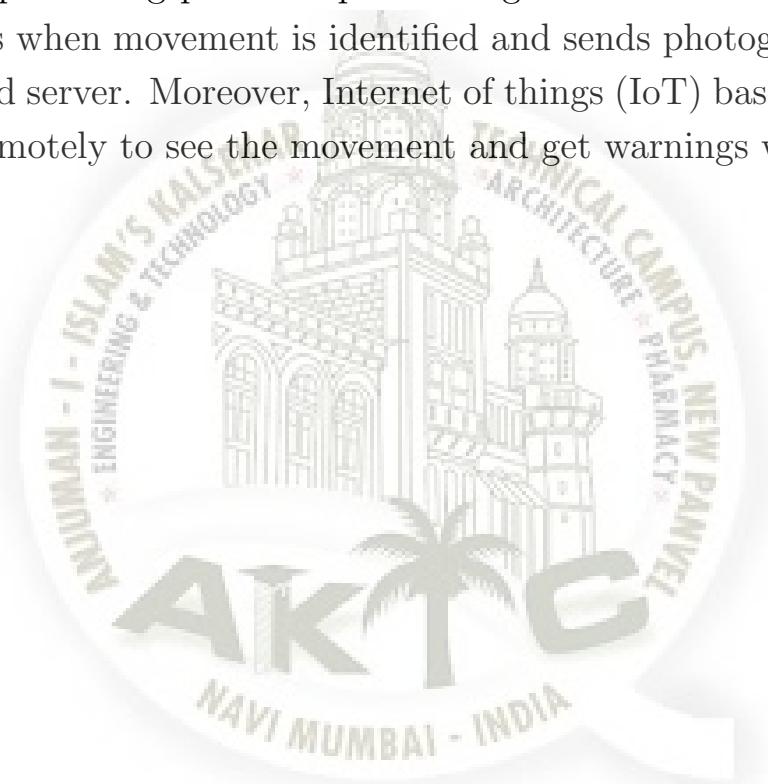

1.1 Objective

In this project, we are working on the security applications. In India, every house or shops are implemented with CCTV cameras. The objective of this project is to capture an image when any motion is detected in prevented or secured areas. This is implemented by using Raspberry Pi, PIR sensor and Camera module.

1.2 Problem Statement

The core problem faced by any system is its cost effectiveness. The existing systems available are CCTV cameras, fingerprint detection, face recognition, so these traditional methods employed for building such security systems includes costly sensors and different modules which unnecessarily increase the cost and complexity and are also difficult to implement.

These limitations provided us an impetus to build a cost effective, efficient, high speed processing security system that can be controlled and monitored miles and miles away through the internet.

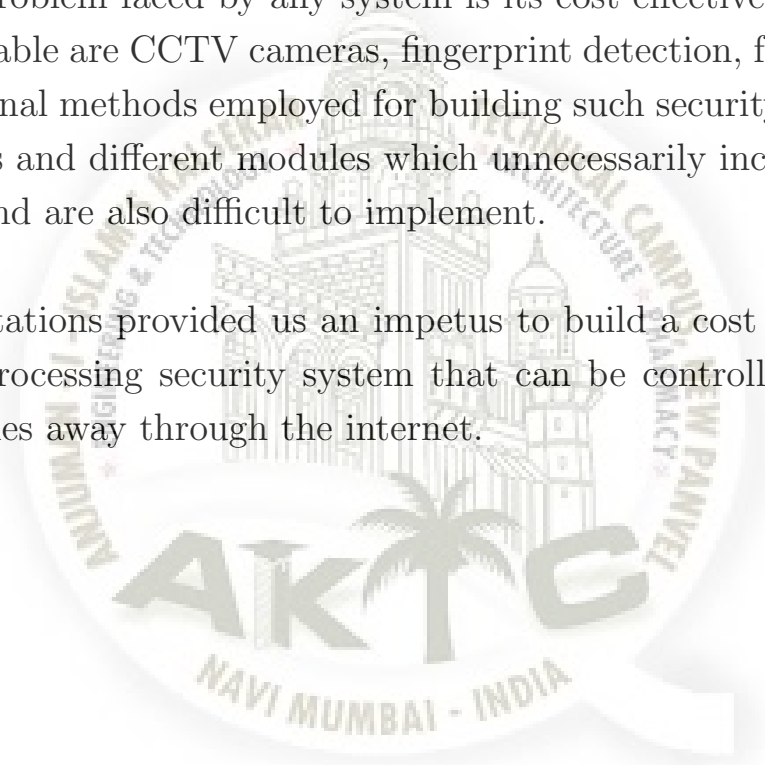

Chapter 2

Literature Survey

2.1 Smart surveillance and Monitoring System using Raspberry pi and Android-:

Author-Priya Patel

Here smart surveillance system operated via android device by owner remotely as well as locally. IoT application for remote controlling is used, system will send the push notification to android device when an intrusion is detected inside the room. It is required to develop and implement and affordable low cost web-camera based surveillance system for remote security monitoring. Authorized user can access to their monitoring system remotely via internet with the use a mobile phone and monitor the situation on application. This entire work is done on Raspberry pi with raspbian operating system ported on it. If more security is required additional live video streaming is also included.

This system has the capability to monitor a location away from the surveillance area through android device. It also consists two parts.

1) Local Access: If person is connected with the local server same as the system, he can control the Raspberry pi and monitor the area in form of image/video through android application.

2) Remote Access: Even if user with android device is away from the system but connected with the separate internet plan then controlling of Raspberry pi is possible with the IoT application named Dataplicity.

2.2 An IoT Approach for Motion Detection using ARM-Based System on Chip-:

Author- Adimulam Padmanabham

The Internet of Things (IoT) is the gathering of billions of end things or devices, from the pocket-sized of enormously competent connected nodes or a high-performance host or cloud platform, cleverly coupled and inter-operating with servers and services. In The wake of Fast moving world, monitoring has become an essential critical. The main purpose of this thesis is motion detecting using Raspberry pi which runs on Frame Difference Algorithm, camera captures the motion when there is a difference between present frame and previous frame, then this image is transferred to a specific folder in the Raspberry. Further the image is sent from Raspberry pi to Drop box automatically or command line interface. Using this technology, we can share our link to Multi users allowing them to access the image whenever they want. Using IFTTT technology mails will automatically trigger once the image reaches the specific folder, before this mail, user will get a mail when motion is detected in Terminal itself.

2.3 An Internet of Things (IoT) Based Security Alert System using Raspberry pi:-

Author- A. Arun Raja

Here a security alert system which records a video when a motion is detected and uploads it to the external server and notifies the user via text message is reported. This application can be used to view the remote activities and notifications can be received whenever the motion is detected. Internet of things basically deals with transferring of use able data without involving human interference's.

2.4 An IoT Approach for Motion Detection using Raspberry pi:-

Author- Aamir Ansari

To describe a security alarm system using low processing power chips using IOT which helps to monitor and get alarms when motion is detected and sends photos and videos to a cloud server. The project aims to simplify motion detection and the interface to be user friendly, which would send prompt notifications when motion is detected. Here a python script is used for motion detection and wput is used for storing the files on an external server. The major of the "Motion Detection" is at homes, buildings and also for surveillance for security. Here they introduce the motion detection system and to contribute to the current security systems. This system would be alternative for expensive security systems.

2.5 Smart Motion Detection System Using Raspberry Pi:-

Author- Swapna Jadhav

In surveillance, CCTV camera is costly because of the use of computer. It reserves to much space for continues recording and require manpower to detect the unauthorized activity. But compared to the existing system Raspberry pi system is much cheaper with better resolution and low power consumption feature. Here pyroelectric infrared (PIR) sensors are used as a simple but powerful people presence triggers. This system is suitable for small personal area surveillance. i.e. personal office cabin, bank locker room, parking entrance. Whenever the motion is detected through PIR sensor inside the room the image is captured through camera and temporarily stored in the raspberry pi module. Internet of Things based application can be used remotely to view the activity and get notifications when motion is detected. System works standalone without the PC once programmed. One android application is used to get the notification on motion detection. Surveillance system consists of mainly two parts: -

1) Hard-wired surveillance system: -

These systems use wires to connect cameras, motion detectors, power supply and LAN cable with Raspberry pi.

2) Remote Access Systems: -

These systems have capability to monitor and control a security system from a location away from the surveillance area through android.

2.6 Advanced Real Time Home Security System Based on Raspberry pi:-

Author- Amol Boke

In advanced real time home security system based on Raspberry pi controller to which the camera is interfaced for monitoring. Here the camera will continuously capture the images and these images are compared with the reference image in the controller. If there is any difference in the captured image and the reference image, then a message will be sent to the user and at the same time the difference images are also sent. It may also be possible that when the message arrives user will be busy and is unable to read the message and reply at that time. So, in this case the processor will wait some time for the feedback is not received in predefined interval then it will raise the alarm. Advanced real time home security system based on Raspberry pi is proposed this provides real time images and videos with low cost and efficient monitoring system that is capable of capturing images. These systems can be useful for home as well as for industrial security system. Another advantage of this system is that because of its small size and portability, it can be placed in any kind of surrounding for surveillance.

2.7 Real Time Video Monitoring System Using Raspberry Pi:-

Author- Sunil Kanzariya

The embedded Real-time video monitoring system based on ARM is designed, in which the embedded chip and the programming techniques are used. The central monitor which adopts Raspberry pi is the core of the whole system. Real time video transmission is widely used in surveillance, conferencing, media broadcasting and applications that include remote assistance. First, USB camera video data are collected by the embedded Linux system. All data are processed, compressed and transferred by the processing chip. Then, video data are sent to the monitor client by wireless network. This embedded monitoring system to overcome the weak points of the traditional video surveillance systems, such as complex structure, poor stability, and expensive cost. It can be widely used in many fields, and also used for long distance transmission.

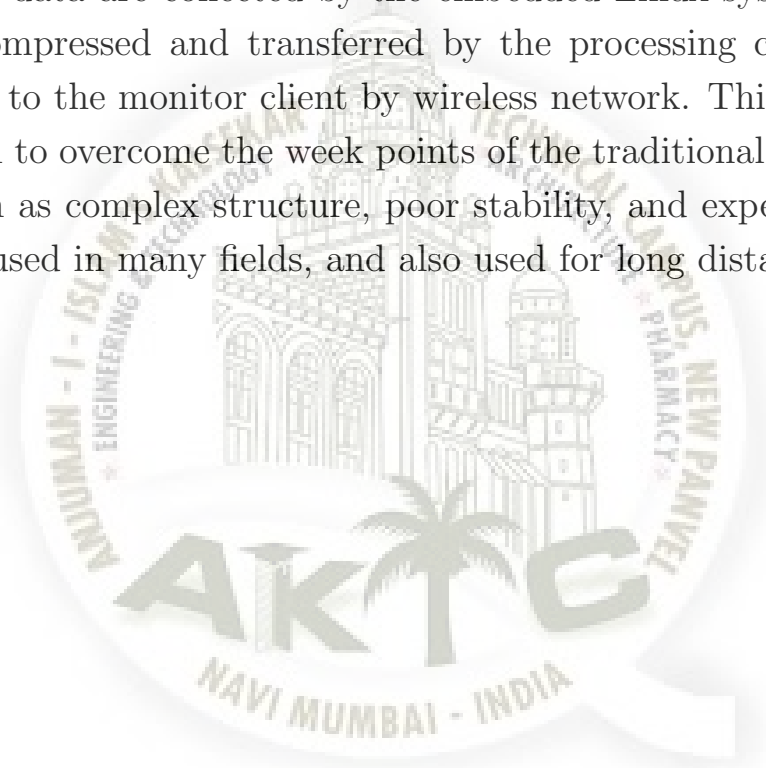

Chapter 3

Proposed System

3.1 Methodology:-

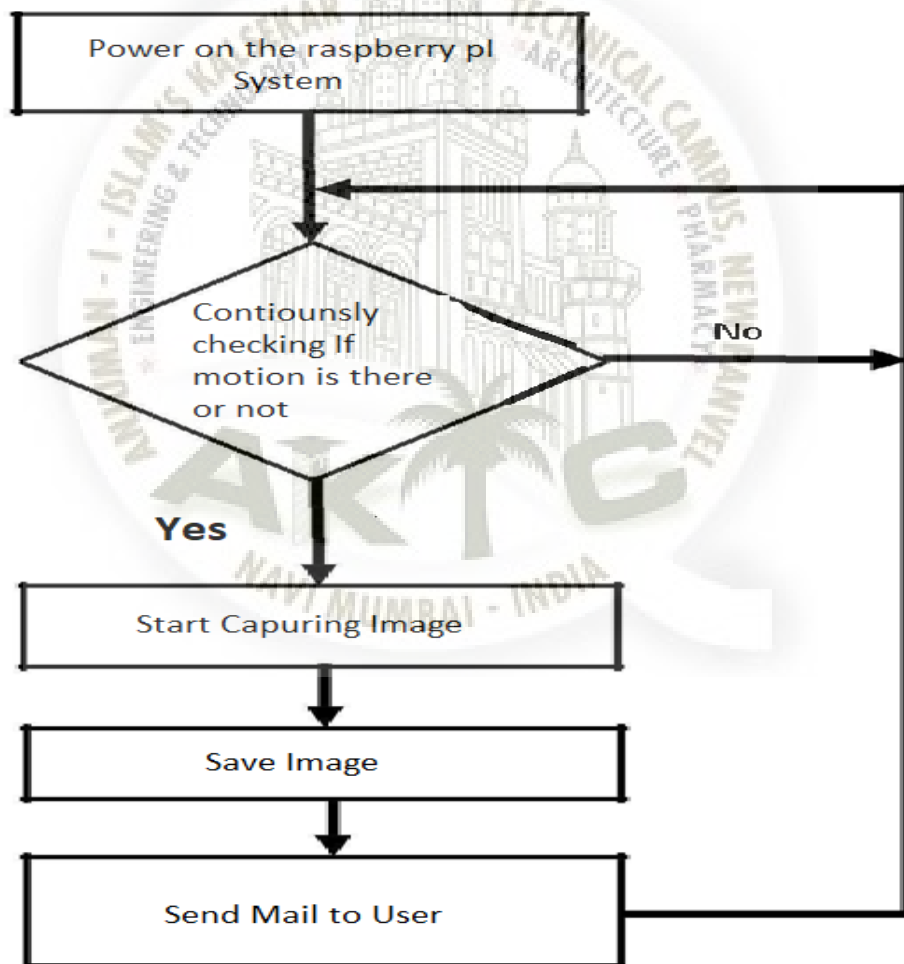

Fig. 3.1: System Flow Diagram

Power(5v) is given to raspberry pi. Then PIR sensor detects motion, if detected then save image. After saving send email and push notification simultaneously. If motion not detected then again go to previous block.

3.2 Block Diagram-:

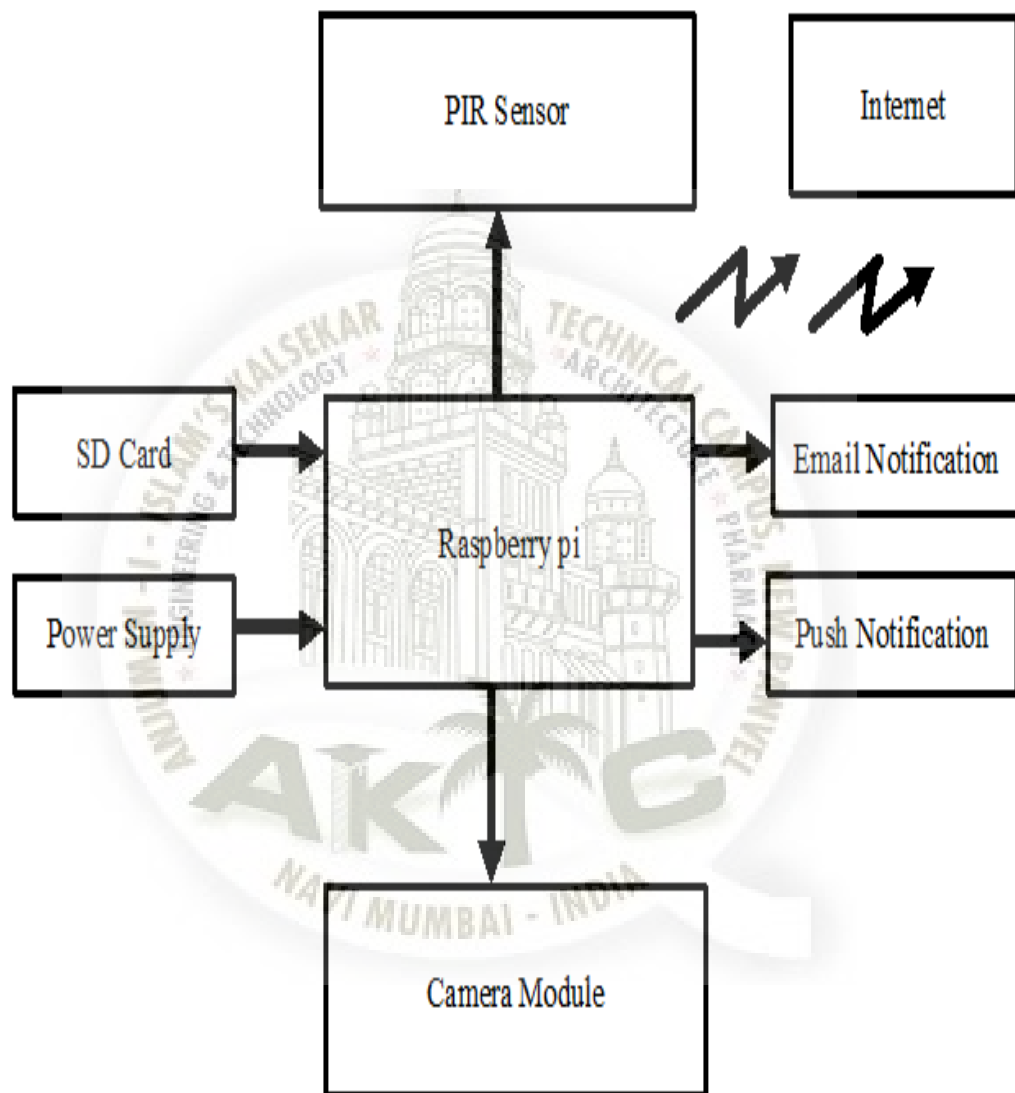

Fig. 3.2: Block Diagram

Smart surveillance system operated via android device by owner can be remotely as well as locally. IoT application for remote controlling is used, system will send the push notification to android device when an intrusion is detected inside the room. It is required to develop and implement the affordable low cost surveillance system for remote security monitoring. Authorized user can access to their monitoring system remotely via internet with the use of mobile phone and monitor the situation on application. This entire work is done on raspberry pi with Raspbian as operating system.

System Monitoring: This system has the capability to monitor a location, away from the surveillance area through android device.

Local Access: If person is connected with local server same as the system, he can control raspberry pi and monitor the area. The block diagram fig.3.2 shows the interfacing of different modules through raspberry pi. Raspberry pi will be placed in surveillance area, spying the activities connected with components like PIR sensor, power supply, camera module. The controlling and monitoring the area can be done from any part of the world through android application. The system consists of camera module to capture the image from the crime scene and then transfer the same to the application. The owner can view the image with secured login and password. We are using internet to control the system as well as sending notification on user mobile as pop up message when an intrusion is detected.

Camera Module-: Camera captures an image and save on raspberry pi. Here we are using pi camera module version 1.

PIR Sensor-: Detect the motion in surveillance area.

Chapter 4

Component Details

4.1 Hardware-:

4.1.1 Raspberry Pi-:

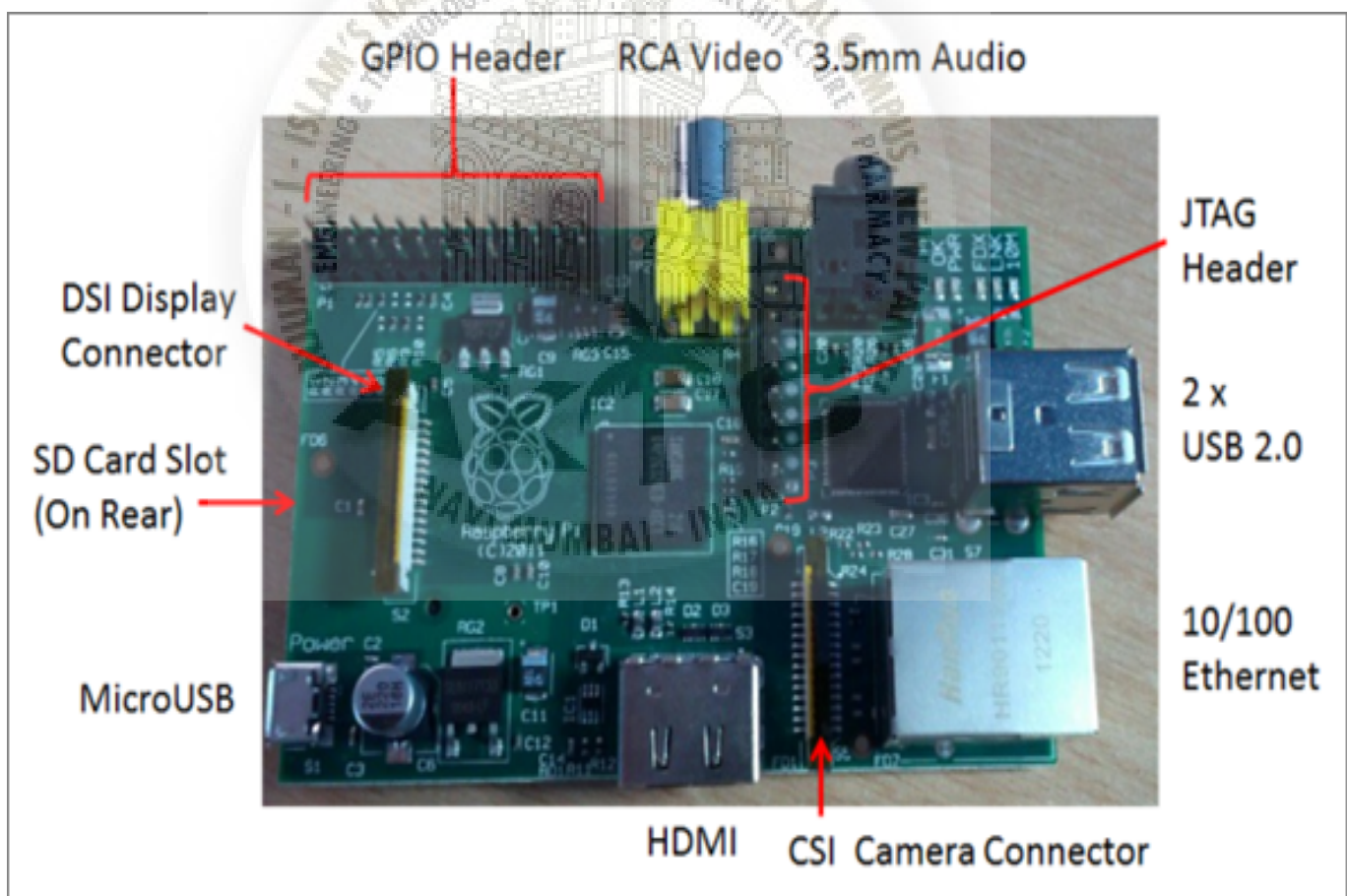

Fig. 4.1: Raspberry pi 3 model B

The Raspberry Pi is a series of small single-board computers developed in the United Kingdom by the Raspberry Pi Foundation. The Raspberry pi is a low cost single board, packing considerable computer power in a size of a credit card. The Raspberry pi board contains many features like camera connector, Ethernet port, GPIO pins for interfacing sensors and switches, USB ports to connect to external devices like keyboard, mouse, WIFI adapter etc., HDMI port to interface to monitors like LCD screens, projectors, TVs etc. and ab audio jack also available. By all these embedded on a single board. The Raspberry pi has no internal mass storage or built-in operating system and hence it requires an SD card Pre-loaded with version of the Linux Operating system. All models of Raspberry pi include an ARM compatible CPU and an on-chip GPU.

The Raspberry Pi 3 is the third-generation Raspberry Pi. It replaced the Raspberry Pi 2 Model B in February 2016

Technical specifications-:

- A 1.2GHz 64-bit quad-core ARMv8
- CPU 802.11n Wireless LAN
- Bluetooth 4.1 Bluetooth Low Energy
- (BLE) 1GB RAM
- 4 USB ports
- 40 GPIO pins Full HDMI port
- Ethernet port
- Combined 3.5mm audio jack
- composite video Camera interface (CSI)
- Display interface (DSI)
- Micro SD card slot (now push-pull rather than push push)
- VideoCore IV 3D graphics core
- Power: 10W(2A)
- System-on-chip used: Broadcom BCM2837

4.1.2 PIR Sensor:-

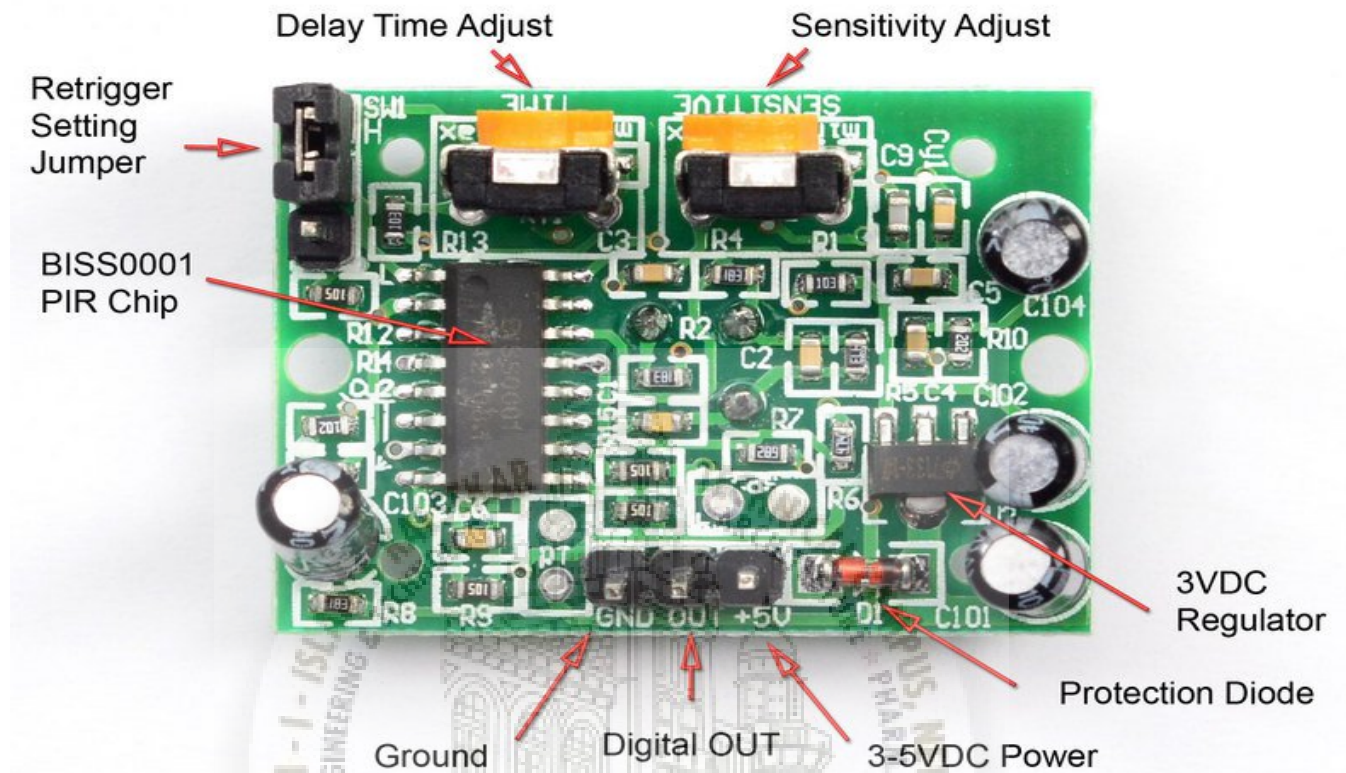

Fig. 4.2: Top View of PIR Sensor

A passive infrared sensor (PIR sensor) is an electronic sensor that measures infrared (IR) light radiating from objects in its field of view. They are most often used in PIR based motion detectors.



Fig. 4.3: Front View of PIR Sensor

All objects with a temperature above absolute zero emit heat energy in the form of radiation. Usually this radiation isn't visible to the human eye because it radiates at infrared wavelengths, but it can be detected by electronic devices designed for such a purpose. The term passive in this instance refers to the fact that PIR devices do not generate or radiate any energy for detection purposes. They work entirely by detecting the energy given off by other objects. PIR sensors don't detect or measure "heat"; instead they detect the infrared radiation emitted or reflected from an object.

Operation-:

An individual PIR sensor detects changes in the amount of infrared radiation impinging upon it, which varies depending on the temperature and surface characteristics of the objects in front of the sensor. When an object, such as a human, passes in front of the background, such as a wall, the temperature at that point in the sensor's field of view will rise from room temperature to body temperature, and then back again. The sensor converts the resulting change in the incoming infrared radiation into a change in the output voltage, and this triggers the detection. Objects of similar temperature but different surface

characteristics may also have a different infrared emission pattern, and thus moving them with respect to the background may trigger the detector as well.

PIRs come in many configurations for a wide variety of applications. The most common models have numerous Fresnel lenses or mirror segments, an effective range of about ten meters (thirty feet), and a field of view less than 180 degrees. Models with wider fields of view, including 360 degrees, are available—typically designed to mount on a ceiling. Some larger PIRs are made with single segment mirrors and can sense changes in infrared energy over thirty meters (one hundred feet) away from the PIR.

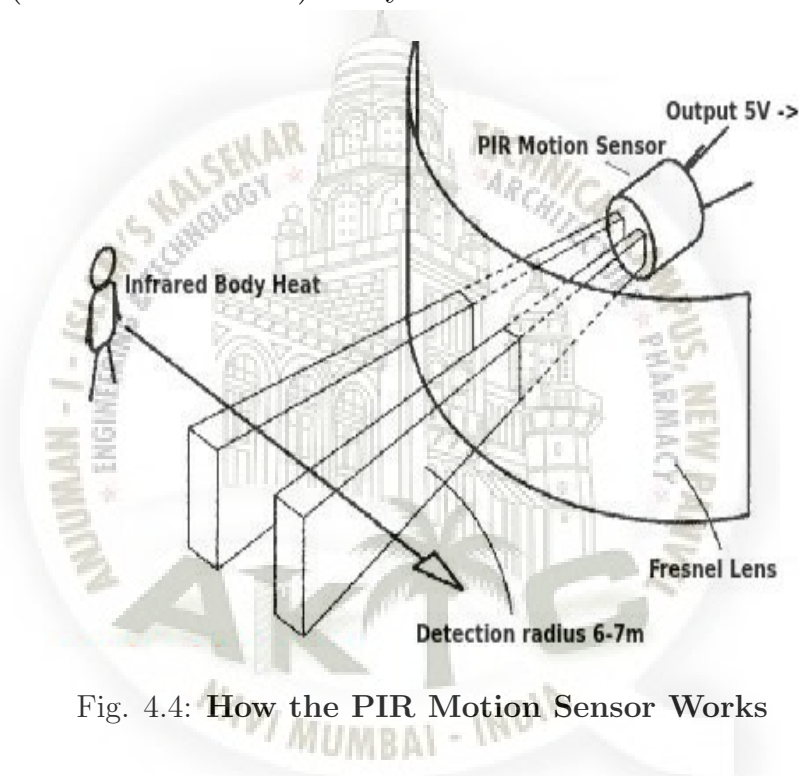

Fig. 4.4: How the PIR Motion Sensor Works

There are also PIR designed with reversible orientation mirrors which allow either broad coverage (110 wide) or very narrow "curtain" coverage, or with individually select-able segments to "shape" the coverage.

4.1.3 Camera Module:-

A camera module is an image sensor integrated with a lens, control electronics, and an interface like CSI, Ethernet. The raspberry pi camera board plugs directly into the CSI connection the Raspberry Pi. It's able to deliver a crystal clear 5mp resolution image or 1080 HD video recording at 30fps. Custom designed and manufactured by the Raspberry Pi foundation in the UK. The raspberry pi camera board features a 5mp (2592*1944 pixels) omni vision 5647 sensor in a fixed focus module. The module attaches to Raspberry pi, by way of a 15-pin ribbon cable, to the dedicated 15 pin MIPI camera serial interface (CSI), which was designed especially for interfacing to cameras. The CSI bus is cable of extremely high data rates and it's exclusively carries pixels' data to the BCM2835 processor.

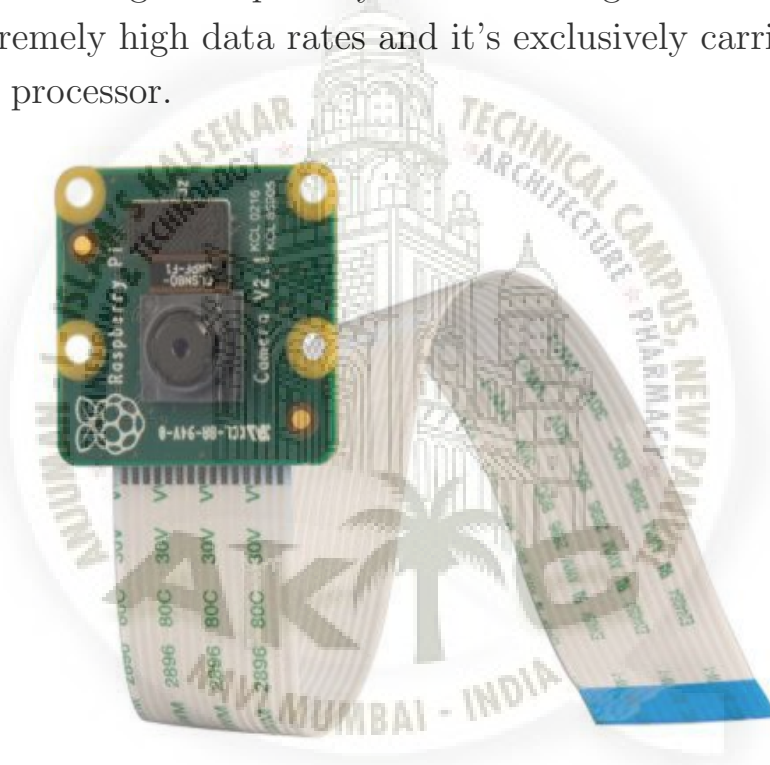

Fig. 4.5: Camera Module v1

The board itself is tiny, at around 25mm*20mm*9mm and weighs just over 3g, making it perfect for mobile or other applications where size and weight are important. The sensor itself has a native resolution of 5 megapixels and has a fixed focus lens onboard. In terms of still images the camera is capable of 2592*1944 pixel static images and supports 1080p(30fps), 720p(60fps) and 640*480p video recording.

Specifications-:

- 5mp omnivision 5647 camera module.
- Still picture resolution: 2592*1944.
- Video: supports 1080p, 720p and 640*480p recording.
- 15-pin MIPI camera serial interface.
- Weight: 3g. • Size: 20*25*9mm.
- Fully compatible with all Raspberry pi versions



4.2 Software-:

4.2.1 Putty Configuration-:

Putty is a free and open-source terminal emulator, serial console and network file transfer application. It supports several network protocols, including SCP, SSH, Telnet, r-login, and raw socket connection. It can also connect to a serial port. The name "Putty" has no definitive meaning. Putty was originally written for Microsoft Windows, but it has been ported to various other operating systems. Official ports are available for some Unix-like platforms, with work-in-progress ports to Classic Mac OS and Mac OS, and unofficial ports have been contributed to platforms such as Symbian, Windows Mobile and Windows Phone. Putty was written and is maintained primarily by Simon Tat-ham.

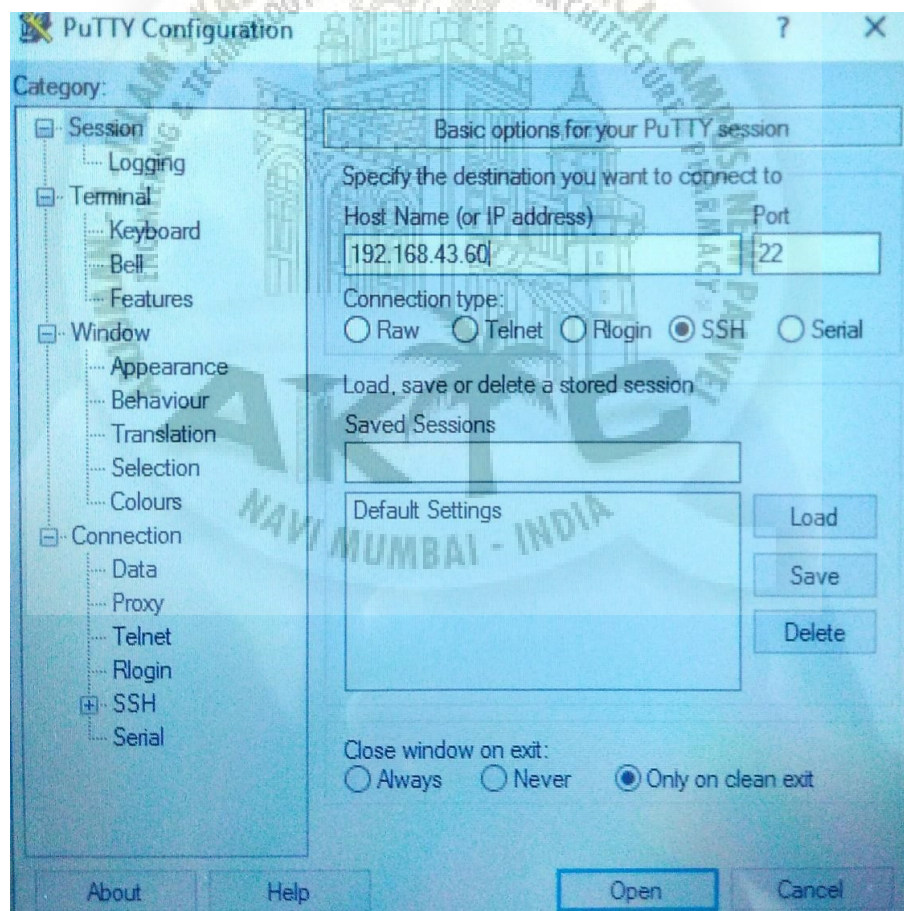

Fig. 4.6: Putty Configuration

Putty consists of several components:

- Putty: The Telnet, r-lo-gin, and SSH client itself, which can also connect to a serial port
- PSCP: an SCP client, i.e. command-line secure file copy
- PSFTP: an SFTP client, i.e. general file transfer sessions much like FTP
- PuTTYtel: A Telnet-only client
- Plink: a command-line interface to the Putty back ends
- Pageant: an SSH authentication agent for Putty, PSCP and Plink
- Puttygen: an RSA, DSA, ECDSA and EdDSA key generation utility
- pterm: a standalone terminal emulator



4.2.2 Programming-:

4.2.3 Detect motion using PIR sensor and Raspberry pi-:

4.2.4 Connect PIR sensor to the pi-:

Many motion detectors use passive infrared (PIR) sensors. A PIR sensor permanently measures infrared light and notices whenever something in the infrared spectrum changes. This is all you need to detect motion, because nearly every object emits infrared light. That's true for everything in front of your house: the ground, a bicycle, a garbage can, and so on. These things emit a constant portion of infrared light, and it does not change rapidly. But if a human being or an animal approaches your front door, the sensor will notice a big variation and fire a signal. The sensor has three pins that you need to connect to the Pi using female/male jumper wires. In the following figure, you can see how Connect the raspberry pi and PIR sensor.

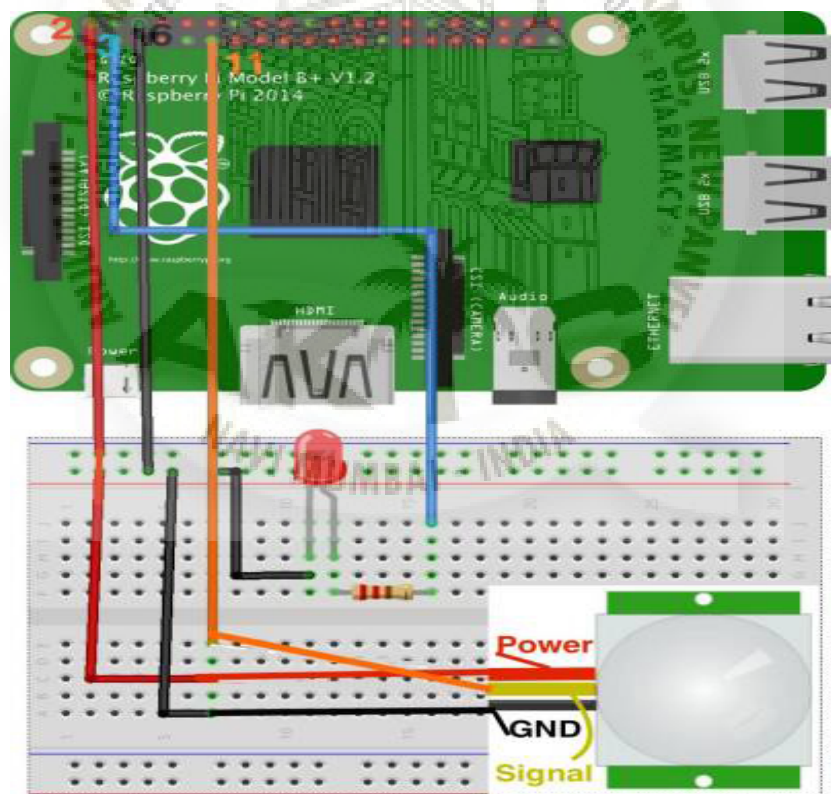

Fig. 4.7: Raspberry pi PIR motion sensor connection

The sensor output 5v signal for a period of one minute as soon as it detects the presence of a person. It offers a tentative range of detection about 6-7 meters and is highly sensitive. When the PIR motion sensor detects a person, it outputs a 5v signal to the raspberry pi through its GPIO and we define what the raspberry pi should do as it detects an intruder through the python coding. Here we are just printing: “intruder detected”.



4.2.5 Motion Detection Program-:

```
#motion detection python program.
```

```
import RPi.GPIO as GPIO
```

```
import time
```

```
GPIO.setwarnings(False)
```

```
GPIO.setmode(GPIO.BOARD)
```

```
GPIO.setup(11, GPIO.IN) #Read output from PIR motion sensor
```

```
GPIO.setup(3, GPIO.OUT) #LED output pin
```

```
while True:
```

```
    i=GPIO.input(11)
```

```
    if i==0:
```

```
        #When output from motion sensor is LOW
```

```
        print ("No intruder",i)
```

```
        GPIO.output(3,0) #Turn OFF LED
```

```
        time.sleep(1)
```

```
    elif i==1:
```

```
        #When output from motion sensor is HIGH
```

```
        print ("intruder detected",i)
```

```
        GPIO.output(3,1) #Turn ON LED
```

```
        time.sleep(5)
```

Output:-

The output of the program is “intruder detected” when we place our hand over the sensor. After removing our hand and waiting some time, it prints: “No intruder”.

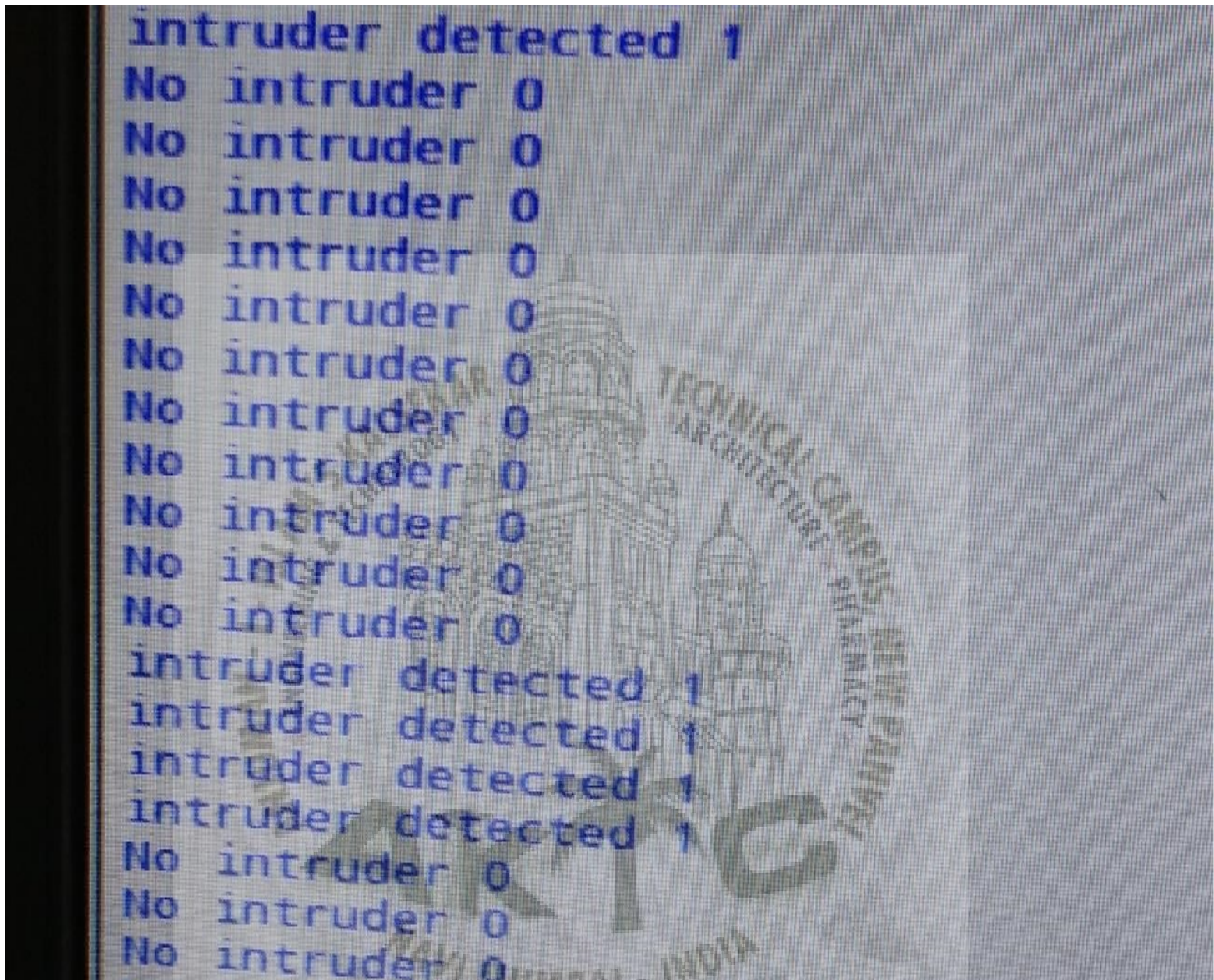

Fig. 4.8: PIR Sensor Output

4.2.6 Connect the Camera Module and Save images-:

4.2.7 Connect the Camera Module-:

First, with the pi switched off, we will need to connect the camera module to the Raspberry pi's camera port, then start up the pi and ensure the software is enabled.

Step1: Locate the camera port and connect the camera.

Step 2:Start up the pi.

Step 3:Open the raspberry pi configuration tool from the main menu.

Step 4:Ensure the camera software is enabled.

4.2.8 Still Pictures-:

Program-:

```
from picamera import PiCamera
from time import sleep

camera = PiCamera()
camera.start_preview()

sleep(5)

camera.capture('/home/pi/Desktop/image.jpg')

camera.stop_preview()
```

Output:-

Run the code and we will see the camera preview open for 5 seconds before capturing a still picture. We will see the preview adjust to a different resolution momentarily as the picture is taken. We will see our photo on the Desktop.

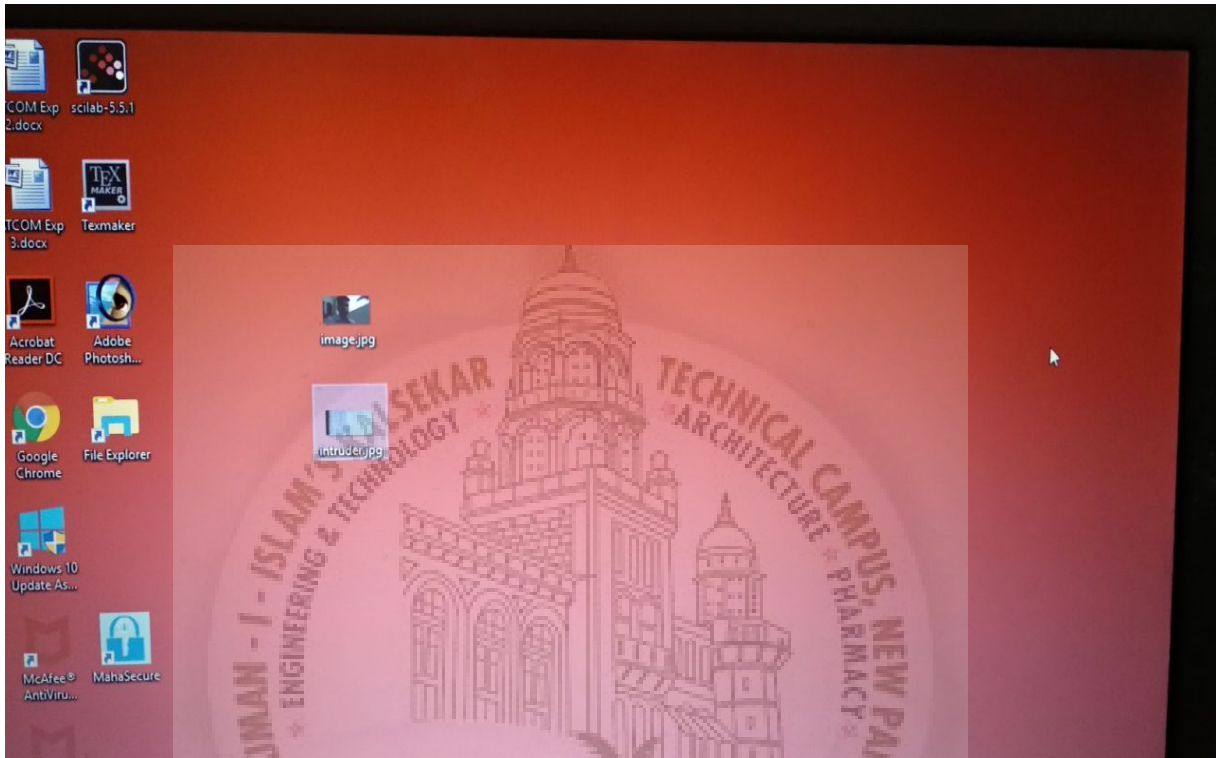

Fig. 4.9: Camera Output

4.2.9 Email Notification-:

There is a native library in python to send emails: `smtplib`. No need to install external libraries.

Program-:

```
import smtplib
from email.mime.multipart import MIMEMultipart
from email.mime.text import MIMEText
from email.mime.base import MIMEBase
from email import encoders

fromaddr = "beprojectextc72@gmail.com"
toaddr = "akib93@gmail.com"

msg = MIMEMultipart()
msg['From'] = fromaddr
msg['To'] = toaddr
msg['Subject'] = "attachment"
body = "intruder detected"
msg.attach(MIMEText(body, 'plain'))
filename = "New intruder.jpg"
attachment = open("/home/pi/Desktop/New intruder.jpg", "rb")
part = MIMEBase('application', 'octet-stream')
part.set_payload((attachment).read())
encoders.encode_base64(part)
part.add_header('Content-Disposition', "attachment; filename= New intruder.jpg")
msg.attach(part)

server = smtplib.SMTP('smtp.gmail.com', 587)

server.starttls()

server.login(fromaddr, "motiondetection")

text = msg.as_string()

server.sendmail(fromaddr, toaddr, text)
server.quit()
```

Note-: Don't forget to enable 'less secure apps' in G-mail Account.

Chapter 5

Results And Discussions

After importing the required packages and running the python code, the setup starts working. Whenever the motion is detected the output screen displays the message “intruder detected”. Simultaneously the camera module starts recording the events and the E-mail and SMS notifications are sent to the user. Below are the results we obtained after running python code successfully.

The first output is shown below. We can see an email with the text message displayed as “intruder detected”. Here we have created Gmail account named “beprojectextc72@gmail.com”. All email notifications will be updated in this. Whenever there is an intruder we will get the following mail as shown in figure 5.1

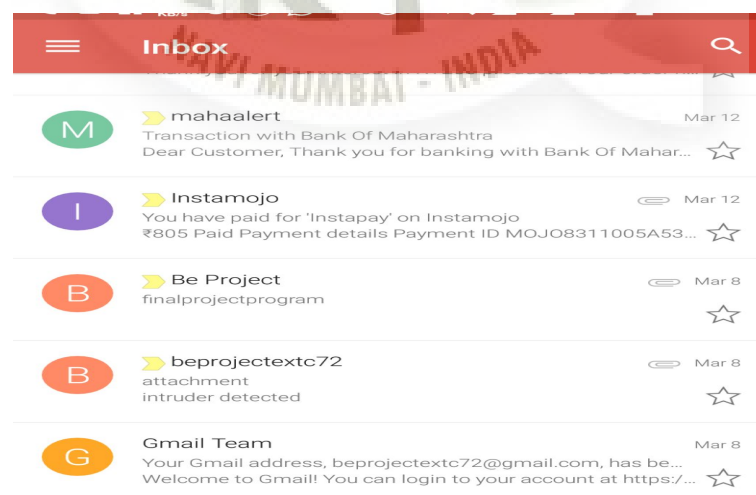

Fig. 5.1: Motion detection images with time

We can see the above email is with an attachment. As soon as intruder will be detected PIR sensor will sense the IR rays emitting from an intruder and will start giving high output. After that camera starts working. Here camera will click the pictures of an intruder as shown in fig 5.2. Then after clicking images third stage of project starts working. Now an authenticate person will get an email as shown in fig 5.1 with an attachment. This attachment is in a form of .jpg file. When an authenticate person will check mail, the following attachment of an intruder will be obtained as shown in fig 5.2.



Fig. 5.2: Motion detection image in email

Chapter 6

Conclusion and Future Scope

6.1 Conclusion

The smart surveillance system has been aimed to design in such a way that it can fulfill the needs of the user for surveillance area. It has countless applications and can be used in different environments and scenarios. For instance, at one scenario it can be used by any person working in industry to be aware of the activity being happened at their own working places, in their absence, while at another instance it can be used for spy purposes at bank lockers, storage houses. Another application is to provide information to the user about what is happening in surveillance area by notification.

6.2 Future Scope

One application should be developed which include pushetta notification as well as the controlling power of raspberry pi from the window. User can also view captured image remotely on this application. Live video streaming can be added as per the user requirement. Power management should also be there and system went on sleep mode when it is no longer in active mode.

The future scope of this system can be extended further by adding additional infrared emitting system to detect the people face if they wore the mask on his/her face. Apart from this we can interface sensors like Gas sensors, Smoke sensors and Fire sensors to give alerts respectively.

Bibliography

- [1] Priya B Patel, Dr. K.R. Bhatt, Viraj M Choksi and Dr. M. B. Potdar “Smart Surveillance and Monitoring System using Raspberry PI and Android” International Journal of Enhanced Research in Science, Technology Engineering ISSN: 2319-7463, Vol. 5 Issue 5, May-2016.
- [2] Aamir Nizam Ansari, Mohamed Sedkyl, Neelam Sharma, Anurag Tyagil “An Internet of Things Approach for Motion Detection using Raspberry Pi” 2015 International Conference on Intelligent Computing and Internet of Things (ICIT).
- [3] Sahil R. Arora, Prof. Amol Boke, Prof. Pragati Kene and Suraj U. Patinge “Advanced Real Time Home Security System Based on Raspberry PI” International Journal of Pure and Applied Research In Engineering And Technology.
- [4] Prof. Uma Nagaraj, Sayali Sonawane, Prachi Kalbhor, Sonali Diware, Shweta Iskande , “Remote Surveillance System for Mobile Application”, International Journal of Engineering Research and Applications, 2012.
- [5] Adimulam Padmanabham and Venugopal “An Internet of Things Approach for Motion Detection using ARM-Based System On Chip” Int. J. Engg. Res. Sci. Tech. 2016.
- [6] Parashiva Murthy B M and Inchara S and Yashaswini K K “Motion Detection using IOT Mechanism” International Journal of Engineering Research in Computer Science and Engineering (IJERCSE) Vol 3, Issue 5, May 2016.

- [7] A. Arun Raja, R.Naveedhab, G.Niranjanadevic and V.Roobini “An Internet of Things (IOT) Based Security Alert System using Raspberry PI” Asia Pacific International Journal of Engg Science,(2016).
- [8] G. Anitha, S. Praveen Kumar “An IOT Approach for Motion Detection and Controlling Home Appliances Without Cloud Server” second national conference.
- [9] Vamsikrishna Patchava, M. Surya Gupta, Virginia Menezes “Surveillance and Monitoring System Using Raspberry pi and SimpleCV” IEEE conference.
- [10] Wilson Feipeng Abya, Jimmy Basa “Low Cost Smart Security Camera with Night Vision Capability Using Raspberry pi and OpenCV” IEEE conference.
- [11] Amit Rana, A.S. Bhalchandra “Machine Monitoring on Cloud using Raspberry pi and Internet of Things” International Journal of Advanced Reasearch in Computer and Communication Engineering.
- [12] Z. Yu and W. Tie-Ning, 'Research on the Visualization of Equipment Support Based on the Technology of Internet of Things', 2012 Second International Conference on Instrumentation, Measurement, Computer, Communication, and Control, 2012.
- [13] Serkan Akbas, Mehmet Akif Efe Suat Ozdemir “Performance Evaluation of PIR Sensor Deployment in Critical Area Surveillance Networks”, 2014 IEEE International Conference on Distributed Computing in Sensor Systems (DCOSS). pp, 327 - 332, May 2014.
- [14] Sundas Zafar “Motion Detecting Camera Security System with Email Notification and live streaming using Raspberry Pi”, 2015.
- [15] Sunil Kanzariya, Vishal Vora “Real Time Video Monitoring System Using Raspberry Pi”, National Conference on Emerging Trends in Computer, Electrical and electronics (ETCEE-2015).

- [16] Khushbu Mehta, Niti Gupta “Vision Based-Real Time Monitoring Security System for Smart Home “, International Journal of Innovative Research in Computer and Communication Engineering, 2016.
- [17] Zhuankun Wu: Initial Study On IOT Security Architecture , 1) Strategy and Decision Making Research(2010).
- [18] Ying-Wen Bai, Zi-Li Xie and Zong-Han Li, “Design and Implementation of a Home Embedded Surveillance System with Ultra-Low Alert Power” IEEE Trans. Consumer Electronics, Vol.57. pp, 153-159, February 2011.
- [19] 20) Raspberry Pi Org. Forum [Online]. Available: <http://www.raspberrypi.org>

