

DUAL AXIS SOLAR TRACKER

*Project Stage-I
Report submitted
in
partial fulfillment of requirement
for the award of degree of*

**Bachelor of Engineering
in
Electrical Engineering**

Submitted by
Name of student

**Meer Sharique Zakir Sultan
Mohd. Shafique
Mohd. Faizan Khan
Pawaskar Abdulmateen**

Under the Guidance of
Prof. Tanveer Khatik



Department of Electrical Engineering
Anjuman-I-Islam's Kalsekar Technical Campus, Panvel
Mumbai University, Mumbai
2020-21

DUAL AXIS SOLAR TRACKER

*Project Stage-I
Report submitted
in
partial fulfillment of requirement
for the award of degree of*

**Bachelor of Engineering
in
Electrical Engineering**

**Submitted by
Name of student**

**Meer Sharique Zakir Sultan
Mohd. Shafique
Mohd. Faizan Khan
Pawaskar Abdulmateen**

*Under the Guidance of
Prof. Tanveer Khatik*



Department of Electrical Engineering
Anjuman-I-Islam's Kalsekar Technical Campus, Panvel
Mumbai University, Mumbai
2020-21

CERTIFICATE

This is to certify that the dissertation titled “Dual Axis Solar Tracker System”, which is being submitted herewith for the award of the, ‘Bachelor of Engineering’ in Electrical Engineering of Anjuman-I-Islam's Kalsekar Technical Campus, New Panvel. This is the result of the original research work and contribution by ‘Mr./Miss.....’ under my supervision and guidance. The work embodied in this dissertation has not formed earlier for the basis of award of any degree or compatible certificate or similar title of this for any other diploma/examining body or university to the best of knowledge and belief.

Place: Panvel

Date:

Name of Guide

Prof. Rizwan Faraday

Guide

H.O.D

Name of Director

DECLARATION

I hereby declare that I have formed, completed and written the dissertation entitled “Dual Axis Solar Tracker System”. It has not previously submitted for the basis of the award of any degree or diploma or either similar title of this for any other diploma/examining body/university.

Place: Panvel

Date:

Name of Student



ACKNOWLEDGEMENT

It is my great fortune that I have got opportunity to carry out this project work under the supervision of **Prof. TANVEER KHATIK** in the Department of Electrical Engineering, A.I.K.T.C School of Engineering and Technology, affiliated to Mumbai University. I express my sincere thanks and deepest sense of gratitude to my guide for his constant support, unparalleled guidance and limitless encouragement.

I wish to convey my gratitude to Prof. Rizwan Faraday, HOD, Department of Electrical Engineering, A.I.K.T.C and to the authority of A.I.K.T.C for providing all kinds of infrastructural facility towards the research work.

I would also like to convey my gratitude to all the faculty members and staffs of the Department of Electrical Engineering, A.I.K.T.C for their whole-hearted cooperation to make this work turn into reality.

.....
Name and Signature of the Students

Place:

Date:

ABSTRAT

The goal of this thesis was to develop a laboratory prototype of a solar tracking system, which is able to enhance the performance of the photovoltaic modules in a solar energy system. The operating principle of the device is to keep the photovoltaic modules constantly aligned with the sunbeams, which maximizes the exposure of solar panel to the Sun's radiation. As a result, more output power can be produced by the solar panel.

The work of the project included hardware design and implementation, together with software programming for the microcontroller unit of the solar tracker. The system utilized an ATmega328P microcontroller to control motion of two servo motors, which rotate solar panel in two axes. The amount of rotation was determined by the microcontroller, based on inputs retrieved from four photo sensors located next to solar panel.

At the end of the project, a functional solar tracking system was designed and implemented. It was able to keep the solar panel aligned with the sun, or any light source repetitively. Design of the solar tracker from this project is also a reference and a starting point for the development of more advanced systems in the future.

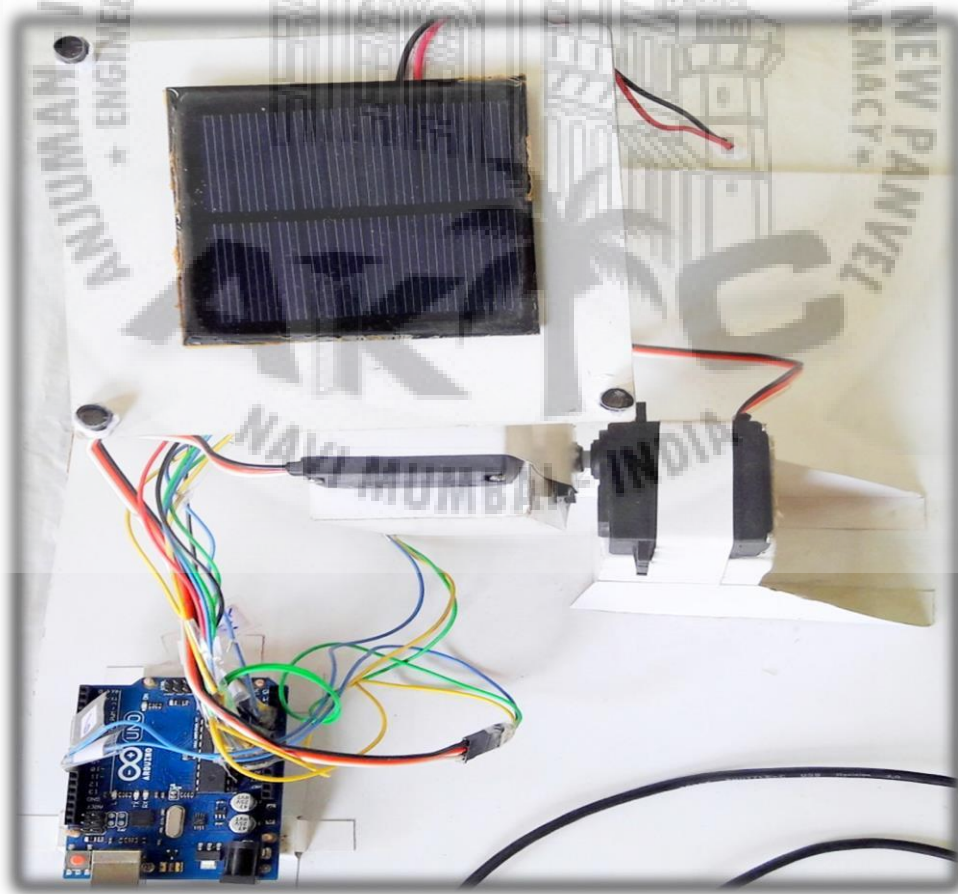

ABBREVIATIONS & ACRONYMS

SAPHT	Solar Assist Plug-In Hybrid Electric Tractor
LDR	Light Dependent Resistor
MOSFET	Metal Oxide Semiconductor Field Effect Transistor
PV	Photovoltaic Cell
IDE	Integrated Development Environment
DC	Direct Current
ADC	Analog-to-Digital Converter
LUX	Luminous Flux (Lumens/m ²)
PWM	Pulse Width Modulation
ICSP	In-Circuit Serial Programming
USB	Universal Serial Bus
CMOS	Complementary Metal-Oxide-Semiconductor
RISC	Reduced Instruction Set Computer
MIPS	Million instructions per second
EEPROM	Electrically Erasable programmable Read-Only Memory
SRAM	Static Random-Access Memory
I/O	Input/ Output
GND	Ground
VCC	Supply Voltage
AREF	Another RDF Encoding Form
PCINT	Pin Change Interrupt Library
RDF	Resource Description Framework
AVR	Alf and Vegard's RISC Processor

List of Photos

Sr.no	Title of Photo	Page.no
1.	Dual Axis Solar Tracker System	i
2.	Arduino UNO	14
3.	Microchip AT mega 328p	15
4.	LDR	19
5.	Servo meter	20
6.	ADC Concept in Arduino UNO	21
7.	Solar Panel	28

List of Figures

Sr.no	Title of Figure	Page.no
1.	Potential Divider Circuit Diagram	5
2.	Servo Control Circuit	5
3.	Basic Circuit Diagram	6
4.	Flow Chart	7
5.	Inverse Square Law	10
6.	Lambert Cosine Law	11
7.	Block Diagram of the Solar Tracker	12
8.	Block Diagram of AVR Architecture	16
9.	Two Axis Tracking System	29

List of Graphs

Sr.no	Title of Graph	Page.no
1.	LDR Variation Graph	19
2.	LDR Graph	26
3.	Relation Between Solar Panel Misalignment and Direct Power Loss	30
4.	Approximate of Power Output Compared to Maximum Output	30

INDEX

Sr. No.	Name of Topic	Page Number
	Abstract	i
	Abbreviations.....	ii
	List of Photos/ Graphs / Tables/ Figures.....	iii
1.	INTRODUCTION.....	1
1.1	Background.....	2
1.2	Statement of Problem.....	3
1.3	Objectives and Significance.....	4
1.4	Working Principle.....	5
1.5	Basic Circuit Diagram.....	6
1.6	Flow Chart.....	7
2.	LITERATURE REVIEW.....	8
3.	SYSTEM DESIGN	10
3.1	Mathematical Model	10
3.2	Hardware Model	12
3.3	Software Program Model	22
4.	DISCUSSION AND CONCLUSIONS.....	28
4.1	About Solar Panel and Connected Load.....	28
4.2	Dual Axis Movement of Solar Tracker	29
4.3	Benefits and Demerits of Solar Energy	31
4.4	Observation and Results.....	32
4.5	Conclusion and Recommendation.....	33
4.6	Application.....	34
4.7	Limitation.....	35
4.6	Scope of Work in the Project	36
	Appendix	
	References	

1. INTRODUCTION

With the unavoidable shortage of fossil fuel sources in the future, renewable types of energy have become a topic of interest for researchers, technicians, investors and decision makers all around the world. New types of energy that are getting attention include hydroelectricity, bioenergy, solar, wind and geothermal energy, tidal power and wave power. Because of their renewability, they are considered as favorable replacements for fossil fuel sources. Among those types of energy, solar photovoltaic (PV) energy is one of the most available resources. This technology has been adopted more widely for residential use nowadays, thanks to research and development activities to improve solar cells' performance and lower the cost. According to International Energy Agency (IEA), worldwide PV capacity has grown at 49% per year on average since early 2000s. Solar PV energy is highly expected to become a major source of power in the future.

However, despite the advantages, solar PV energy is still far from replacing traditional sources on the market. It is still a challenge to maximize power output of PV systems in areas that don't receive a large amount of solar radiation. We still need more advanced technologies from manufacturers to improve the capability of PV materials, but improvement of system design and module construction is a feasible approach to make solar PV power more efficient, thus being a reliable choice for customers. Aiming for that purpose, this project had been carried out to support the development of such promising technology.

One of the main methods of increasing efficiency is to maximize the duration of exposure to the Sun. Tracking systems help achieve this by keeping PV solar panels aligned at the appropriate angle with the sun rays at any time. The goal of this project is to build a prototype of light tracking system at smaller scale, but the design can be applied for any solar energy system in practice. It is also expected from this project a quantitative measurement of how well tracking system performs compared to system with fixed mounting method.

1.1. BACKGROUND

There is a great and growing need for renewable energy, in particular green energy. In years to come we will want a source of energy that will leave future generations with a sustainable energy source. A few good reasons to improve our green energy market are because not only do we want to have renewable energy for future generations, but we also want to have a sustainable energy market in future. Green energy has shown sustainable growth in past years, where oil has obviously not. In order to power our homes, businesses, and most aspects of our daily lives we require electricity, which requires massive power plants and spending billions of dollars to run them. But what if we could avoid all the resources that are used generating this energy, and replace them with green energy that could provide power directly to the consumers like businesses, the military or even private homes. The military will most likely be one the major user of renewable energy in the future. The department of defence plans on opening up 16 million acres of land for renewable energy development, which includes solar energy development. To highlight how new this is, the DOD only made this announcement in early August, meaning solar energy is a major market and a technology of great interest to our nation. There are also many other major solar energy projects that the military is partaking in such as The Sterling solar power renewable energy construction project which have supplied an Army depot outside Salt Lake City with approximately 30% of their power, potentially powering up to 400 homes. Another project is the renewable energy project at the U.S. Army Garrison Kaiserslautern in Kaiserslautern, Germany that will generate enough energy to power 500 homes. In future there are plans to generate enough power on military installations to power 750,000 homes by 2025. Currently in order to run a military base large generator are required, which are reported to be not nearly as efficient as solar panels could be, and consume large amounts of fuel in order to run. The needs of future military instalments are to have renewable energy sources that require less maintenance and are more energy efficient as opposed to petroleum. In addition, solar energy will not only be used for military bases, but also for mobile military units as well, which will be more efficient at providing soldiers energy for their equipment used in the field. Overall, it is dangerous to depend strictly on fossil fuels. It is dangerous politically, economically, and naturally. Politically we want the country to not have to depend on petroleum from other countries. Being dependent on other countries, especially as the top consumer of fossil fuels, would have a negative impact on our country in the future; that is when they resources disappeared.

On the economic side, our country would be in better shape to be more self-sustaining in future. On the environmental side, when it comes to burning these fossil fuels, although debated on how bad the environmental effect is, it is known to produce large amounts of carbon dioxide. Some have complained about the true benefits of solar power, and argue that it is not cost effective enough to be worthwhile. On the other hand, reports have shown that costs have gone down for something like instalments at home, and that the payoff for installing them would be even greater. The cost per watt has been estimated at \$4.85/Watt, which is said to be a 50% increase in the last 5 years. Although the cost for at home installation is said to cost around \$5,000, the life of solar panels is said to be incredibly long, and only lose around half a percent of their maximum power each year. This makes them a great technology to invest in and continue to develop, so that in future they can produce even more power. This way, states like California can reach their goal of 33% solar energy dependency by 2025. Like this many countries have started to make this move toward green energy and energy independence; this is because they know it is the energy of the future.

1.2. STATEMENT OF PROBLEMS

The main goal is to keep solar PV panel perpendicular to the sun throughout the day in order to increase the energy generation. Dual axis solar tracking system can be an effective way to increase the efficiency of solar cells. The devastating problem on both biotic and abiotic components of our home (i.e., Pollution) can be reduced by using solar energy as the major source for power generation. The natural gift like fossil fuels, woods, etc. Which are limited in amount can be saved from crisis and extinction. For people, due to its more efficiency and less harmful impacts dual axis solar tracking system might be good decision for the intermediate future. So, this project can practically demonstrate effect of this variation to people.

1.3. OBJECTIVES

1.3.1. Specific Objectives

- i. To design and fabricate a dual axis PV system that tracks the sun path.

1.3.2. General Objectives

- i. To study different solar parameters and methods of harvesting solar energy.
- ii. To understand the working mechanism of PV module and tracking system.

1.4. SIGNIFICANCE

- Solar tracking systems continually orient photovoltaic panels towards the sun and can help maximize your investment in PV system.
- One-time investment which provides higher efficiency and flexibility on dependency.
- Energy production is an optimum and energy output is increased year around.

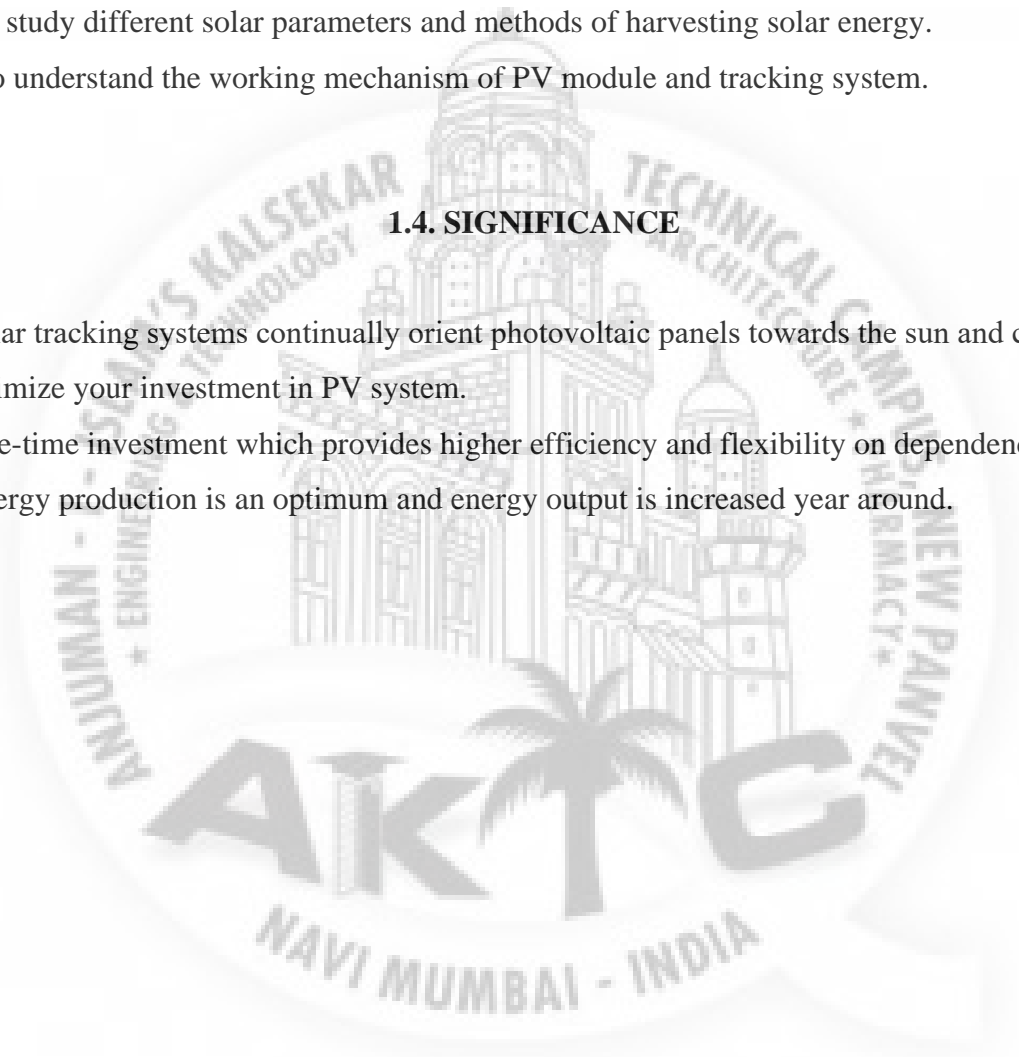

1.5. WORKING PRINCIPLE

- Resistance of LDR depends on intensity of the light and it varies according to it. The higher is the intensity of light, lower will be the LDR resistance and due to this the output voltage lowers and when the light intensity is low, higher will be the LDR resistance and thus higher output voltage is obtained.
- A potential divider circuit is used to get the output voltage from the sensors (LDRs).

The circuit is shown here.

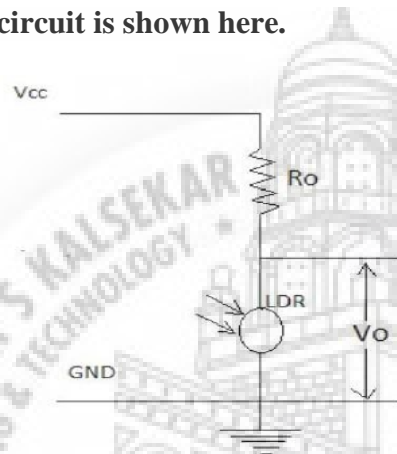

- The LDR senses the analog input in voltages between 0 to 5 volts and provides a digital number at the output which generally ranges from 0 to 1023.
- Now this will give feedback to the microcontroller using the Arduino software (IDE).
- The servo motor position can be controlled by this mechanism which is discussed later in the hardware model.

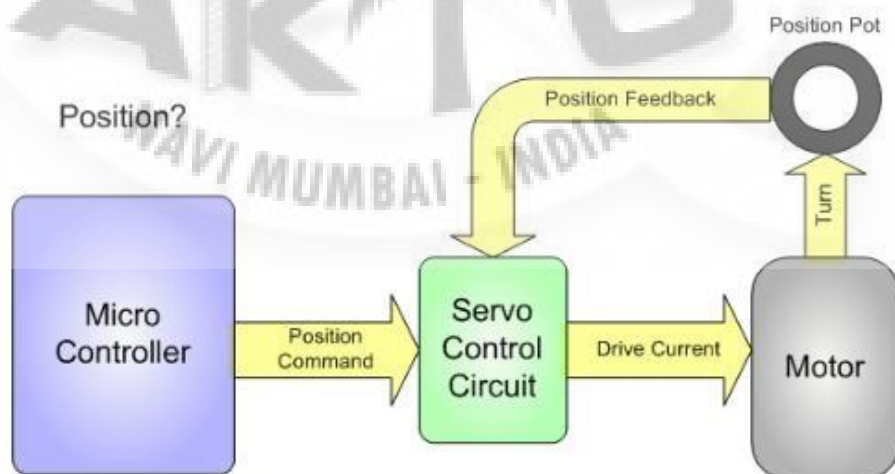

- The tracker finally adjusts its position sensing the maximum intensity of light falling perpendicular to it and stays there till it notices any further change.
- The sensitivity of the LDR depends on point source of light. It hardly shows any effect on diffuse lighting condition.

1.6. BASIC CIRCUIT DIAGRAM

An overview of the required circuit for the Dual-axes solar tracker is shown here.

The 5V supply is fed from an USB 5V dc voltage source through Arduino Board.

Servo X :Rotates solar panel along X direction



Servo Y :Rotates solar panel along Y direction

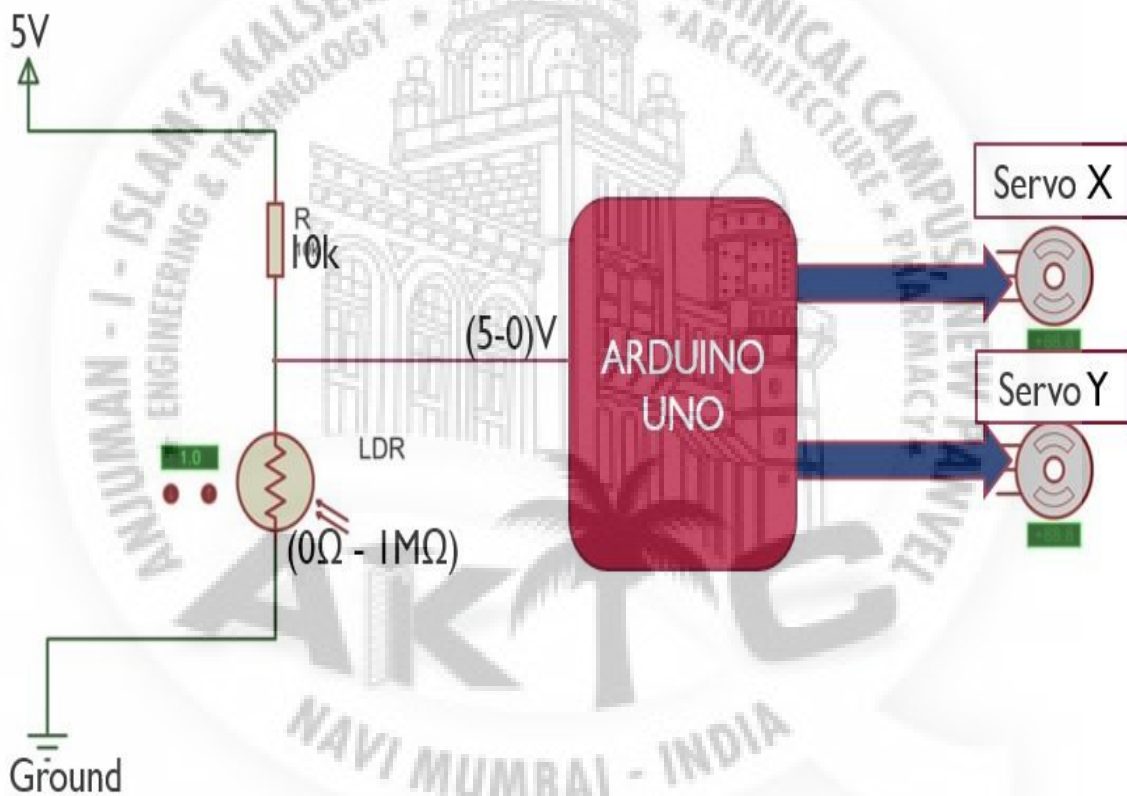

1.7. FLOW CHART

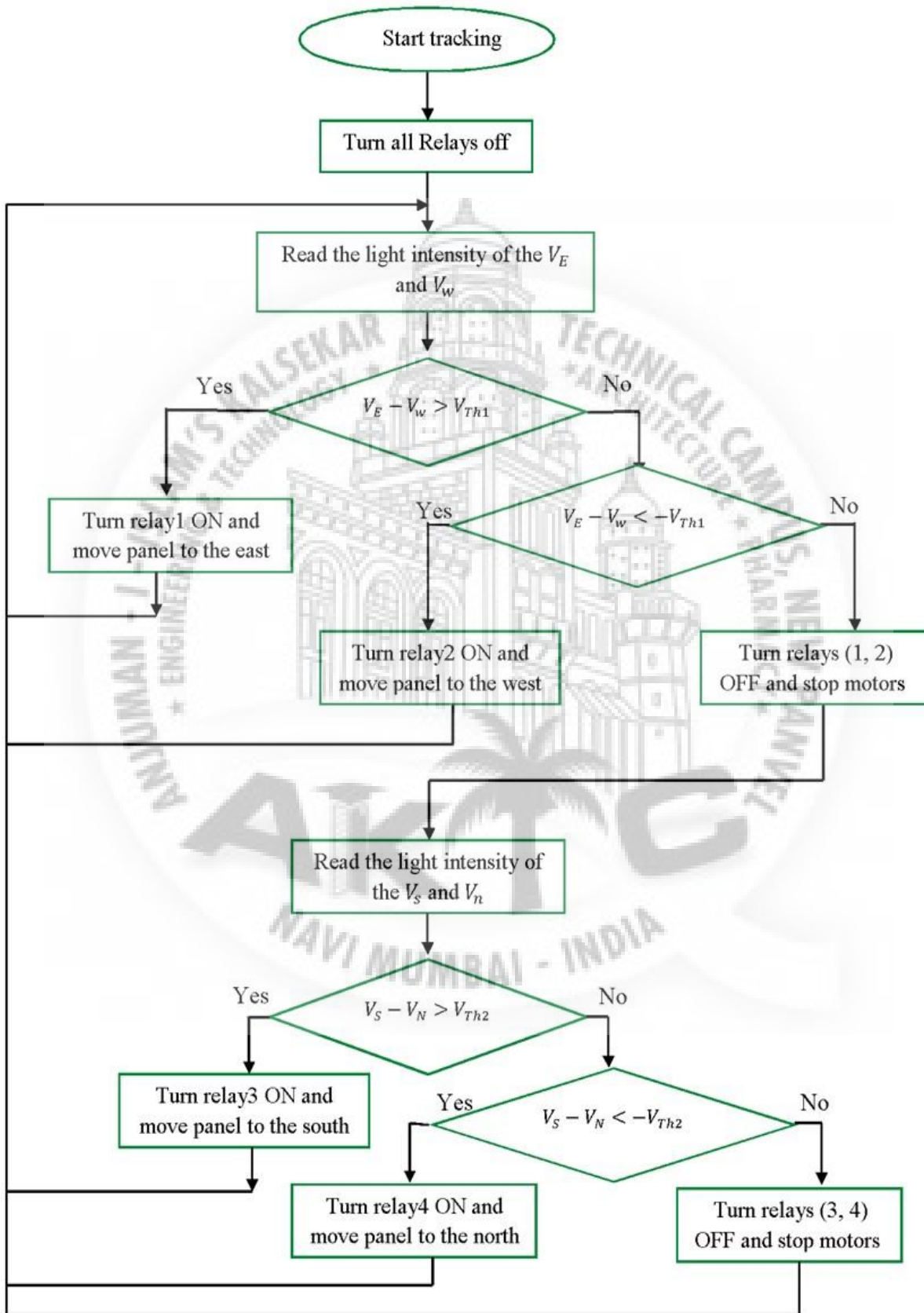

2. LITERATURE REVIEW

Hossein Mousazadeh et Al., [(2011), Journal of Solar Energy Engineering, Vol.133] studied and investigated maximization of collected energy from an on-board PV array, on a solar assist plug-in hybrid electric tractor (SAPHT). Using four light dependent resistive sensors a sun-tracking system on a mobile structure was constructed and evaluated. The experimental tests using the sun-tracking system showed that 30% more energy was collected in comparison to that of the horizontally fixed mode. Four LDR sensors were used to sense the direct beams of sun. Each pair of LDRs was separated by an obstruction as a shading device. A microcontroller based electronic drive board was used as an interface between the hardware and the software. For driving of each motor, a power MOSFET was used to control the actuators. The experimental results indicated that the designed system was very robust and effective.

K.S. Madhu et al., (2012) International Journal of Scientific & Engineering Research vol. 3, 2229–5518, states that a single axis tracker tracks the sun east to west, and a two-axis tracker tracks the daily east to west movement of the sun and the seasonal declination movement of the sun. Concentrates solar power systems use lenses or mirrors and tracking systems to focus a large area of sunlight into a small beam. PV converts light into electric current using the photoelectric effect. Solar power is the conversion of sunlight into electricity. Test results indicate that the increase in power efficiency of tracking solar plate in normal days is 26 to 38% compared to fixed plate. And during cloudy or rainy days it's varies at any level.

The US Patent no. 0215199 A1 [2007] by **Robert H. Dold** describes a two- axis solar tracker capable of withstanding the extreme weather conditions. The solar tracker includes a solar array, a frame, a base, a pivot frame, and a first and second actuator. The solar array is mounted to the frame and captures sunlight. The base is pivotally connected to the frame and defines a pivot axis for elevational movement of the solar array. The pivot frame is also pivotally connected to the frame and defines a pivot axis for azimuthal movement of the solar array. The base is pivotally connected to the frame and defines a pivot axis for elevational movement of the solar array. The pivot frame is also pivotally connected to the frame and defines a pivot axis for azimuthal movement of the solar array. The first actuator controls elevational movement of the solar array and the second actuator controls azimuthal movement of the solar array. The solar tracker is pivotable between a raised position and a stowed position

Ahmed Rhif et al., (2012), International Journal of Control Theory & Computer Modeling Vol.2, review the literature on tracking process for the dual axis sun tracker by a sliding mode control law. The sun tracker considered in this study has two degrees of freedom and is significant due to lack of sensors. In this way, the tracker will have a set of sun positions at every second during the day for a period of five years. After sunset, the tracker goes back to the initial position corresponding to sunrise. Experimental measurements show that this autonomic dual axis sun tracker increases the power production by over 40%. Experimental results show the effectiveness of the sliding mode control in the tracking process, its robustness and the high estimation quality of the sliding mode observer.

Okpeki U.K.et. Al., International Journal of Engineering & Science Vol. 2 (2013) PP. 32-38, describes the design and construction of a bi-directional solar tracking system. The constructed device was implemented by integrating it with 900V inverter and 12volts, 100AH battery. The amount of power available from a photovoltaic panel is determined by three parameters, the type and area of the materials, the intensity of the sunlight and the wavelength of the sunlight. With advancement in solar panel technology, parameter one, the type and area of the material had been fully improved upon and standardized. In this research work the other two parameters were fully addressed, as this device ensures maximum intensity of sun rays hitting the surface of the panel from sunrise to sunset. Test showed that power used by tracker system is less than the power gain by tracking the sun accurately. The most important conclusion of this research is the total cost of construction of the tracker system is very low.

Qiang Xiei's US Patent No.0051017 A1 [2010] refers to a solar collector which may receive and direct solar radiation onto a photovoltaic (or, solar) cell. A concentrating solar collector may also convert the received solar radiation into a concentrated radiation beam prior to directing the radiation onto the solar cell. In some aspects, determination of the target tracker position in the second coordinate system includes subtracting 360° from an azimuth angle in the first coordinate system if the azimuth angle in the first coordinate system is between $+180^\circ$ and $+360^\circ$, wherein the azimuth angle in the second coordinate system is determined to be equal to the azimuth angle in the first coordinate system if the azimuth angle in the first coordinate system is between 0 and $+180^\circ$.

3. SYSTEM DESIGN

3.1. MATHEMATICAL MODEL

MATHEMATICAL EQUATIONS REQUIRED

INVERSE SQUARE LAW

The illumination upon a surface varies inversely as the square of the distance of the surface from the source. Thus, if the illumination at a surface 1 meter from the source is I units, then the illumination at 2 meters will be $I/4$, at 3 meters will be $I/9$ and so on.

In fact, inverse square law operates only when the light rays are from a **point source** and are **incident normally upon the surface**.

Thus, illumination in lamberts/m² on a normal plane = **Candle power/ (Distance in meters)²**

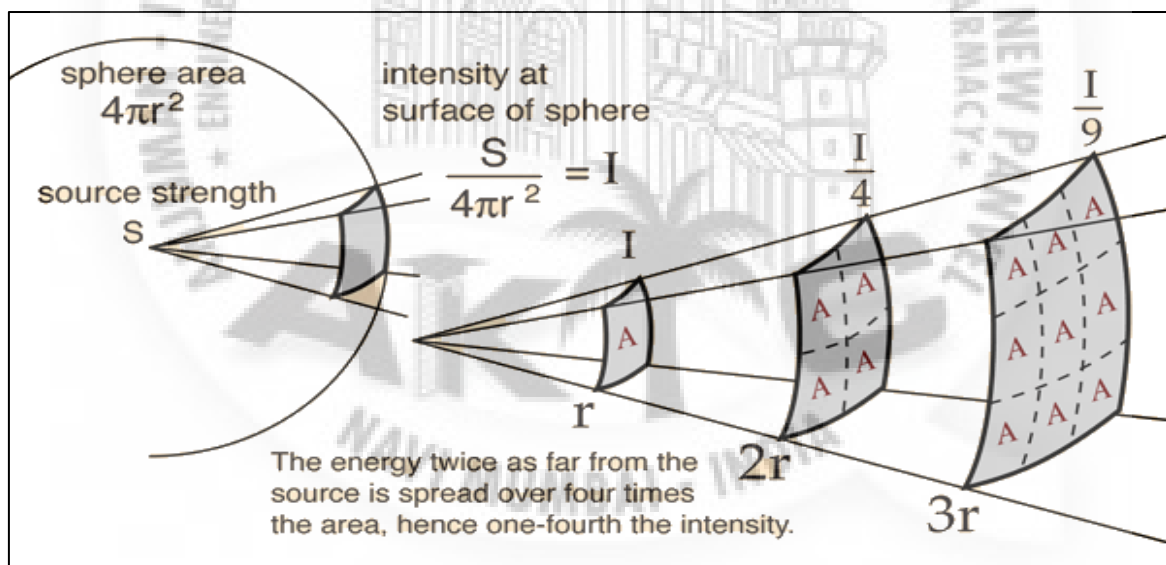

LAMBERT'S COSINE LAW

The illumination received on a surface is proportional to the cosine of the angle between the direction of the incident light rays and normal to the surface at the point of incidence. This is mainly due to the reduction of the projected area as the angle of incidence increases.

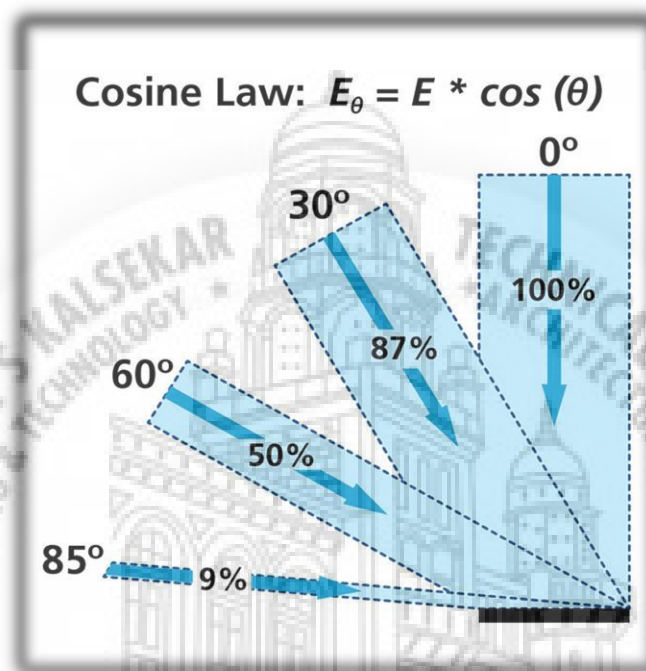

Thus, the equations are:

$$E_{\theta} = E \cos \theta = \frac{I \cos \theta}{D^2}$$

where,

E_{θ} = illumination on horizontal plane

E = illumination due to light normally incident

θ = the angle of incidence

D = distance from the surface

3.2. HARDWARE MODEL

BLOCK DIAGRAM OF THE SOLAR TRACKER:

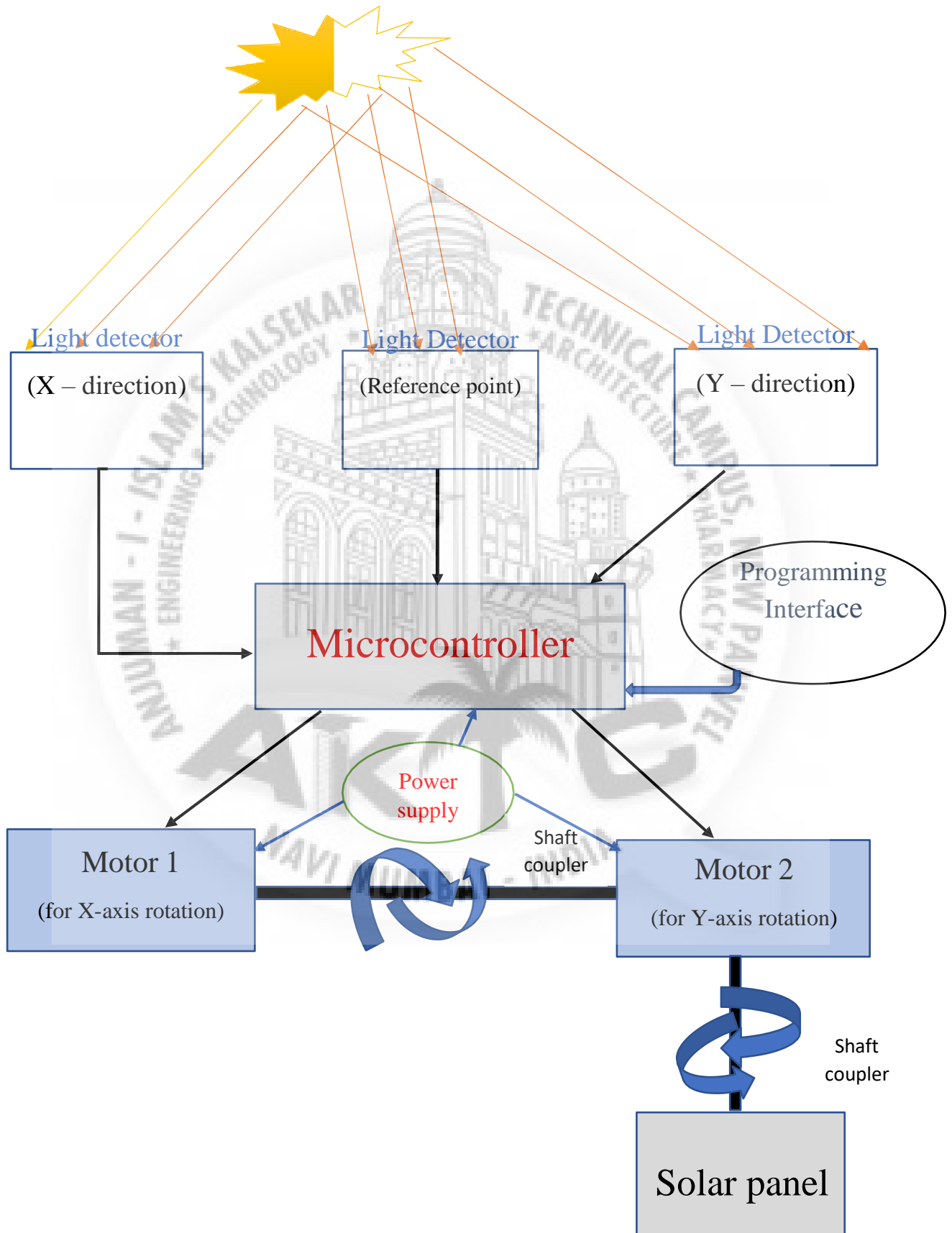

EXPLANATION OF THE BLOCK DIAGRAM

As we see in the block diagram, there are three Light Dependent Resistors (LDRs) which are placed on a common plate with solar panel. Light from a source strikes on them by different amounts. Due to their inherent property of decreasing resistance with increasing incident light intensity, *i.e.* photoconductivity, the value of resistances of all the LDRs is not always same.

Each LDR sends equivalent signal of their respective resistance value to the Microcontroller which is configured by required programming logic. The values are compared with each other by considering a particular LDR value as reference.

One of the two dc servo motors is mechanically attached with the driving axle of the other one so that the former will move with rotation of the axle of latter one. The axle of the former servo motor is used to drive a solar panel. These two-servo motors are arranged in such a way that the solar panel can move along X-axis as well as Y-axis.

The microcontroller sends appropriate signals to the servo motors based on the input signals received from the LDRs. One servo motor is used for tracking along x-axis and the other is for y-axis tracking. In this way the solar tracking system is designed.

ARDUINO UNO

The **Arduino Uno** is a microcontroller board based on the ATmega328. Arduino is an open-source, prototyping platform and its simplicity makes it ideal for hobbyists to use as well as professionals. The Arduino Uno has 14 digital input/output pins (of which 6 can be used as PWM outputs), 6 analog inputs, a 16 MHz crystal oscillator, a USB connection, a power jack, an ICSP header, and a reset button. It contains everything needed to support the microcontroller; simply connect it to a computer with a USB cable or power it with an AC-to-DC adapter or battery to get started.

The Arduino Uno differs from all preceding boards in that it does not use the FTDI USB-to-serial driver chip. Instead, it features the Atmega8U2 microcontroller chip programmed as a USB-to-serial converter.

“Uno” means one in Italian and is named to mark the upcoming release of Arduino 1.0. The Arduino Uno and version 1.0 will be the reference versions of Arduino, moving forward. The Uno is the latest in a series of USB Arduino boards, and the reference model for the Arduino platform.

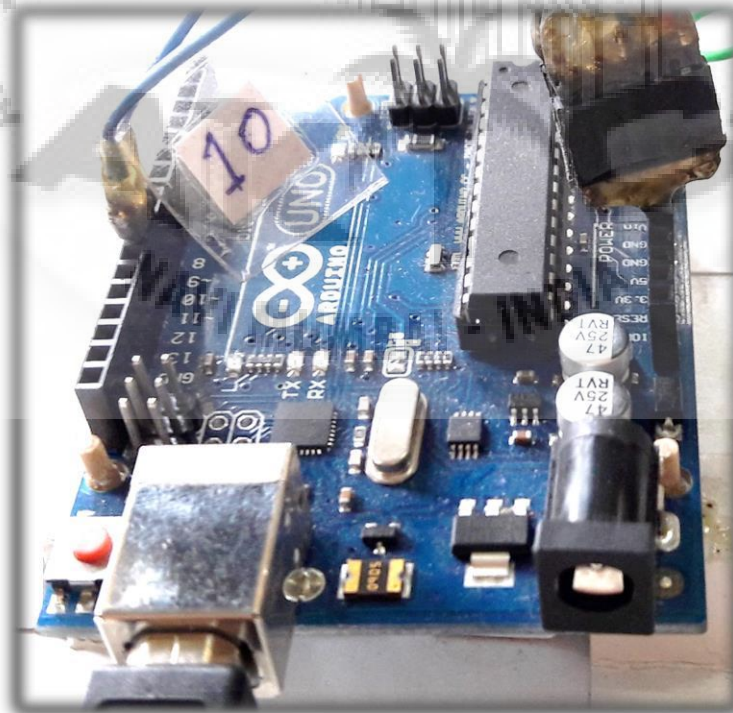

➤ **THE ATMEGA328P-PU ATMEL 8 BIT 32K AVR MICROCONTROLLER**

The Atmel®picoPower®Atmega328/P is a low-power CMOS 8-bit microcontroller based on the AVR® enhanced RISC architecture.

PIN DIAGRAM:

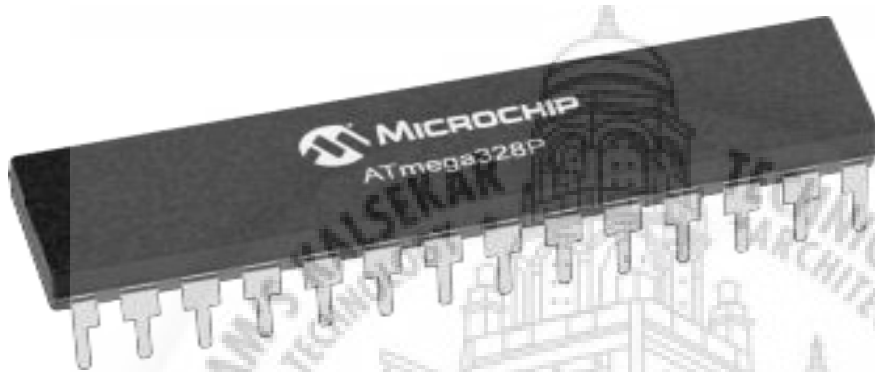

Pin layout of Atmega328p is showed below:

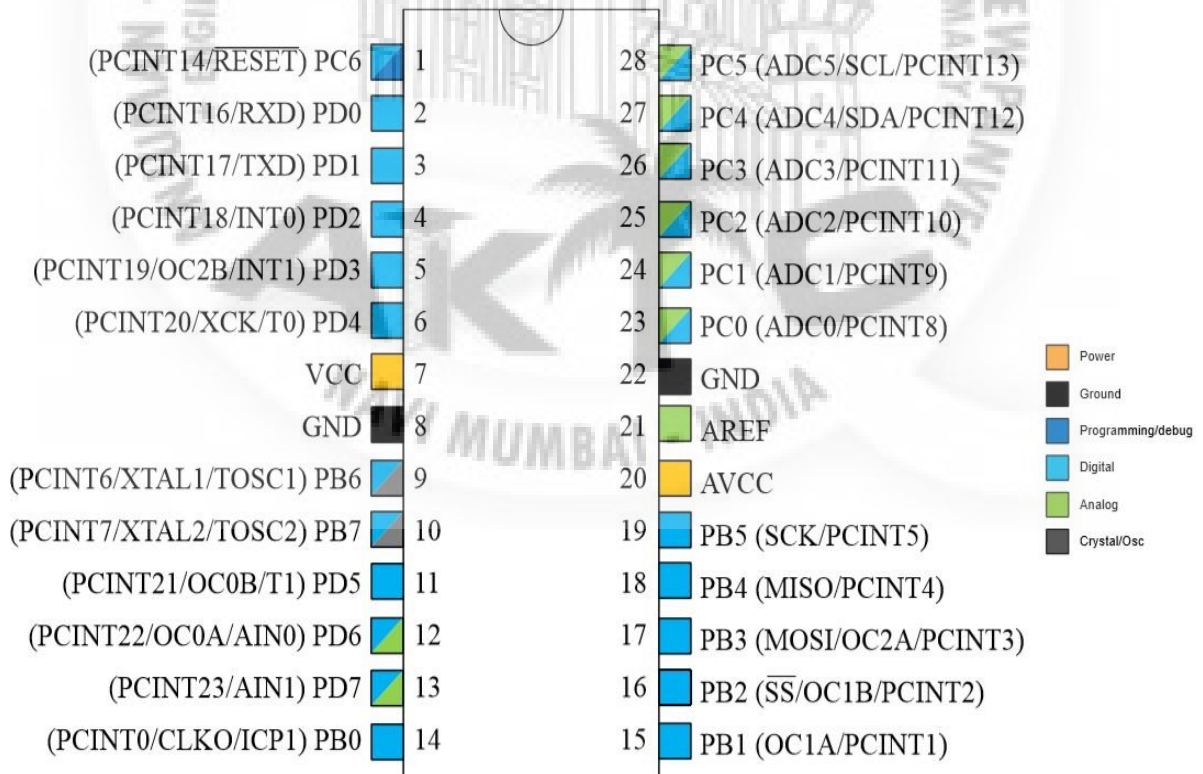

AVR CPU CORE ARCHITECTURE

The main function of the CPU core is to ensure correct program execution. The CPU must therefore be able to access memories, perform calculations, control peripherals, and handle interrupts.

Flash, EEPROM, and SRAM are all integrated onto a single chip, removing the need for external memory in most applications. Some devices have a parallel external bus option to allow adding additional data memory or memory-mapped devices. Almost all devices (except the smallest Tiny AVR chips) have serial interfaces, which can be used to connect larger serial EEPROMs or flash chips.

BLOCK DIAGRAM OF AVR ARCHITECTURE

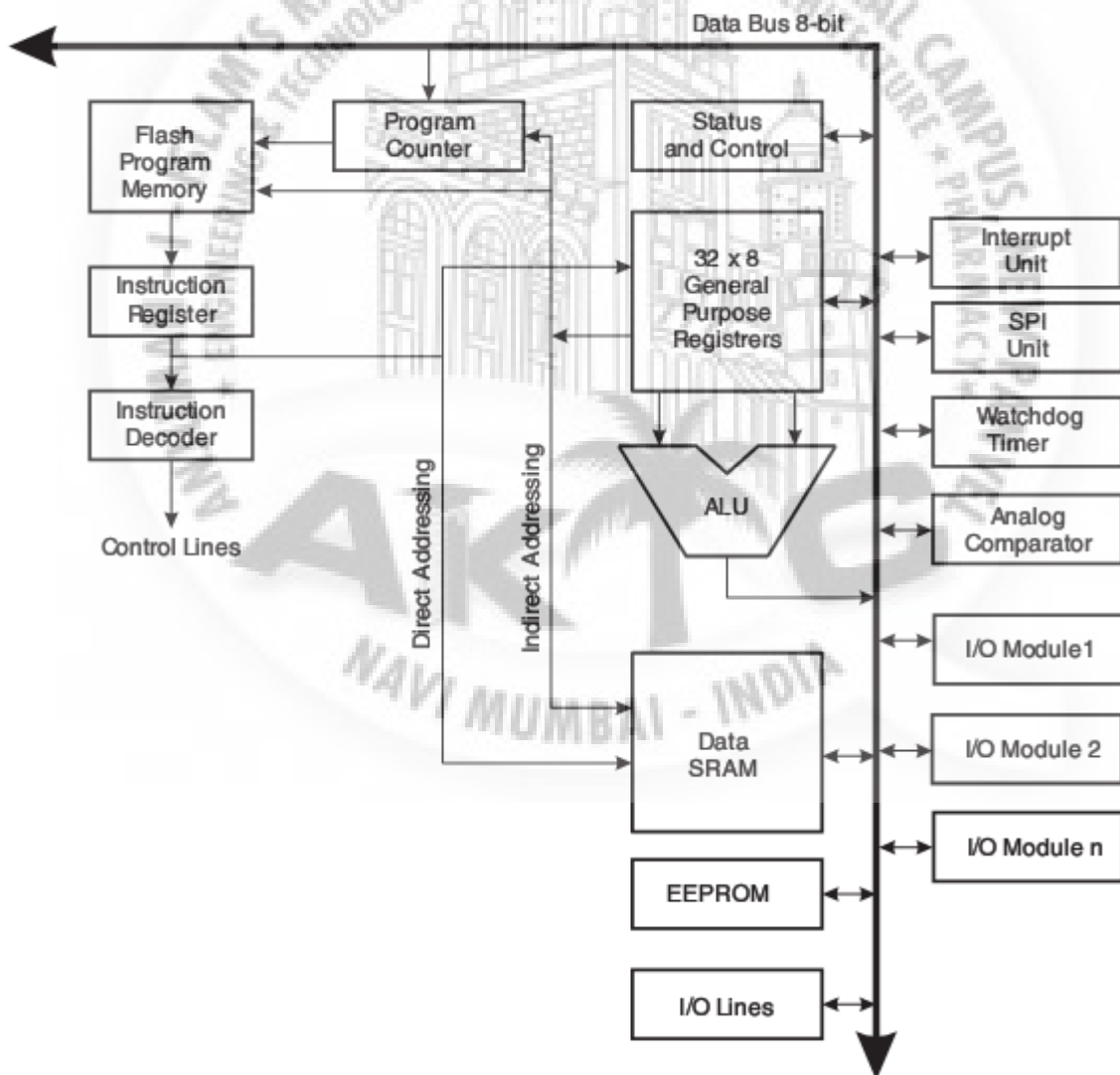

CPU

The CPU of the AVR microcontroller is same but so simple like the one in a computer. The main purpose of the CPU is to confirm correct program performance. Therefore, the CPU must be able to access perform calculations, memories, control peripherals & handle interrupts. The CPUs of Atmel's 8-bit and 32-bit AVR are based on an innovative "Harvard architecture" thus every IC has two buses namely one instruction bus and data bus. The CPU reads executable instructions in instruction bus, wherein the data bus, is to read or write the corresponding data. The CPU core of the AVR consists of the ALU, General Purpose Registers, Program Counter, Instruction Register, Instruction Decoder, Status Register and Stack Pointer

Flash Program Memory

The program of the AVR microcontroller is stored in non-volatile programmable Flash program memory which is just similar to the flash storage in your SD Card or Mp3 Player. The Flash program memory is separated into two units. The first unit is the Application Flash section. It is where the program of the AVR is stored. The second section is named as the Boot Flash section and can be fixed to perform directly when the device is powered up. One significant fact to note is that the microcontrollers Flash program memory has a resolution of at least 10,000 writes/erase cycles.

SRAM

The SRAM (Static Random-Access Memory) of the AVR microcontroller is just like computer RAM. While the registers are used to execute calculations, the SRAM is used to supply data through the runtime. This volatile memory is prearranged in 8-bit registers.

EEPROM

The term EEPROM stands for Electrically Erasable Read-Only Memory is like a nonvolatile memory, but you can't run a program from it, but it is used as long-time storage. The EEPROM doesn't get removed when the IC loses power. It's a great place for storing data like device parameters and configuration of the system at runtime so that it can continue between resets of the application processor. One significant fact to note is that the EEPROM memory of the AVR has a limited lifetime of 100,000 writes / EEPROM page – reads are limitless. Keep this in mind in your application and try to keep writing to a minimum, so that you only write the small amount of info required for your application every time you update the EEPROM.

Digital I/O Modules

The digital I/O modules let digital communication or logic communication with the AVR microcontroller and the exterior world. Communication signals are that of TTL/CMOS logic.

Analog I/O Modules

Analog I/O modules are used to input or output analog information from or to the exterior world. These modules comprise analog comparators and analog-to-digital converters (ADC).

Interrupt Unit

Interrupts have enabled the microcontroller to monitor particular events in the background while performing an application program & respond to the occurrence if required pausing the unique program. This is all synchronized by the interrupt Unit.

Timer

Most AVR microcontrollers have at least one Timer or Counter module which is used to achieve timing or counting operations in the microcontroller. These comprise time stamping, counting events, measuring intervals, etc.

LDR

- It is a photo-resistor is a device whose resistivity is a function of the incident electromagnetic radiation. Hence, they are light sensitive devices. They are also called as photo conductors, photo conductive cells or simply photocells.
- They are made up of semiconductor materials having high resistance.
- LDR works on the principle of photo conductivity.

Photo conductivity is an optical phenomenon in which the material's conductivity is increased when light is absorbed by the material.

The most common type of LDR has a resistance that falls with an increase in the light intensity falling upon the device (as shown in the image below). The resistance of an LDR may typically have the following resistances:

Daylight = 5000Ω

Dark = 20000000Ω



Therefore, it is seen that there is a large variation between these figures. If this variation is plotted on a graph, something similar to the figure given below can be seen.

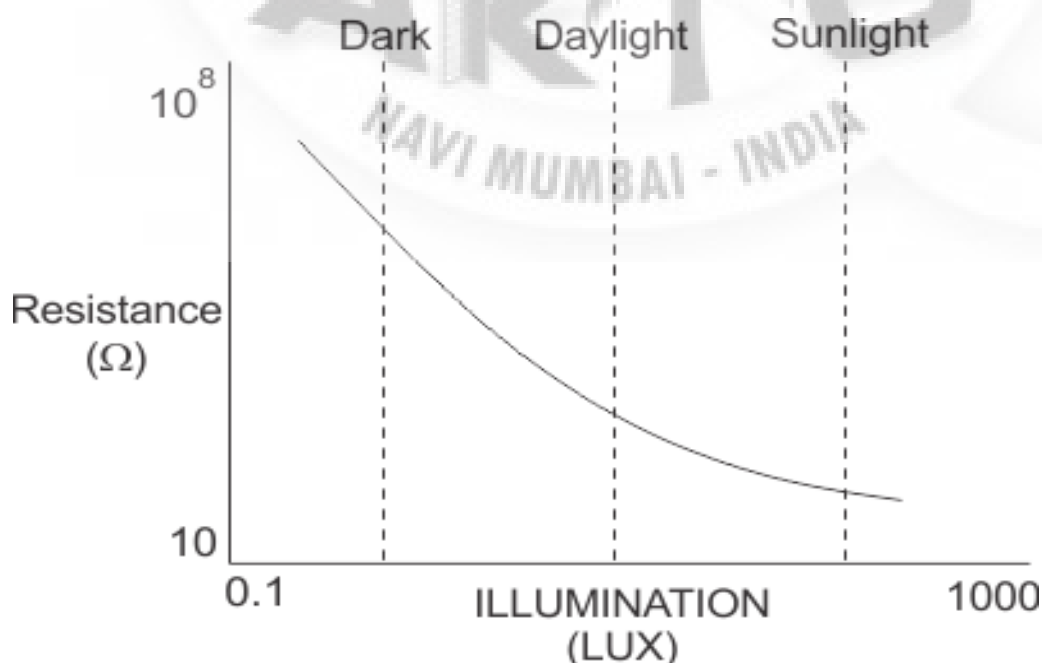

SERVO MOTOR

A DC servo motor consists of a small DC motor, feedback potentiometer, gearbox, motor drive electronic circuit and electronic feedback control loop. It is more or less similar to the normal DC motor.

The stator of the motor consists of a cylindrical frame and the magnet is attached to the inside of the frame.

A brush is built with an armature coil that supplies the current to the commutator. At the back of the shaft, a detector is built into the rotor in order to detect the rotation speed.

With this construction, it is simple to design a controller using simple circuitry because the torque is proportional to the amount of current flow through the armature.

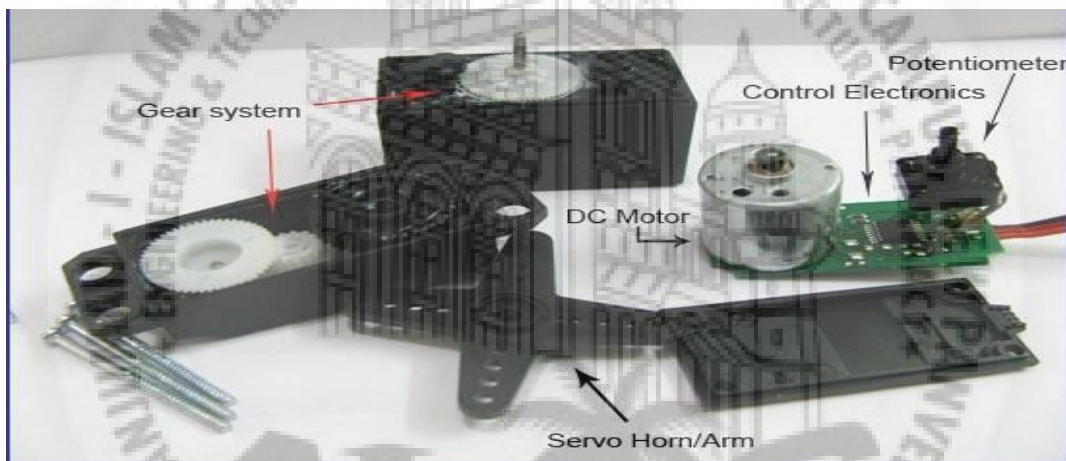

ADC CONCEPT IN ARDUINO UNO



Arduino uno board has 6 ADC input ports. Among those any one or all of them can be used as inputs for analog voltage. The **Arduino Uno ADC** is of 10-bit resolution (so the integer values from $(0-(2^{10}) 1023)$). This means that it will map input voltages between 0 and 5 volts into integer values between 0 and 1023. So, for every $(5/1024= 4.9\text{mV})$ per unit.

The UNO ADC channels have a default reference value of 5V. This means we can give a maximum input voltage of 5V for ADC conversion at any input channel. Since some sensors provide voltages from 0-2.5V, with a 5V reference we get lesser accuracy, so we have a instruction that enables us to change this reference value. So, for changing the reference value we have (“**analogReference();**”).

As default we get the maximum board ADC resolution which is 10bits, this resolution can be changed by using instruction (“**analogReadResolution(bits);**”).

3.3. SOFTWARE PROGRAM MODEL

PROGRAMMING CODE:

```
#include <Servo.h>

Servo myservo;

Servo ourservo;

int posx = 90; // initial position is top

int posy = 90;

int sens1 = A0; // (x,0) LDR

int sens2 = A1; // (0,0) LDR

int sens3 = A2; // (0,y) LDR

int tolerance = 2;

void setup()
{
myservo.attach(9); // pin9
ourservo.attach(10); // pin10
pinMode(sens1, INPUT);
pinMode(sens2, INPUT);
pinMode(sens3, INPUT);

myservo.write(posx);

delay(1000); // buffer delay

ourservo.write(posy);

delay(1000);
}
```

```
void loop()
{
  //For First Axis

  int val1 = analogRead(sens1); // read sensor 1

  int val2 = analogRead(sens2); // read sensor 2

  if((abs(val1 - val2) <= tolerance) || (abs(val2 - val1) <= tolerance))
  {
    //do nothing
  }
  else {
    if(val1 > val2)
    {
      posx = --posx;
    }
    if(val1 < val2)
    {
      posx = ++posx;
    }
  }

  myservo.write(posx); // write the position to servo

  delay(50);

  int val3 = analogRead(sens3); // read sensor 3

  val2 = analogRead(sens2); // read sensor 2

  val3 = analogRead(sens3); // read sensor 3
```



```
//For Second Axis  
if((abs(val2 - val3) <= tolerance) || (abs(val3 - val2) <= tolerance))  
{  
  //do nothing  
}  
else {  
  if(val2 > val3)  
  {  
    posy = ++posy;  
  }  
  if(val2 < val3)  
  {  
    posy = --posy;  
  }  
  if(posy > 150) { posy = 150; }  
  if(posy < 30) { posy = 30; }  
  ourservo.write(posy);  
  delay(50);  
}
```

DESCRIPTION OF THE SOFTWARE PROGRAM

STEPS:

- First of all, both the servos are declared and object is created to control the servo motors.
- The variables **posx** and **posy** are used to store the reference servo positions.
- The ADC input pins for LDRs are selected for dual direction movement and one for reference.
- A tolerance or a constant value is selected to establish the working of the motors.
- The servos are attached on digital pins to the servo object.
- The required analog pins are selected as input using pin Mode (pin, mode)
- The servos are sets to mid-point or original position with a 1000ms or 1sec delay to catch up with the user.
- Three variables are chosen to read the analog values and map it into integers value between 0 and 1023.
- If the difference between the two variables is less than the tolerance value then it will stay to its or original location else it shows movement towards the direction of maximum intensity of light by incrementing or decrementing the values of posx and posy.
- The position is then written to servo and the loop repeats till it encounter any changes in the values of input greater than the minimum tolerance.
- If the position becomes greater than 150° then position will be set to 150° only and if the position of the motor is less than 30° then it would be kept at 30° only as the lower and upper limit angles are chosen to be 30° and 150° respectively.

3.4. LDR PROGRAM AND GRAPH

```
void setup()
{
  Serial.begin(9600);
}

void loop()
{
  int sensorValue = analogRead(A0);
  Serial.println(sensorValue);
  delay(10);
}
```

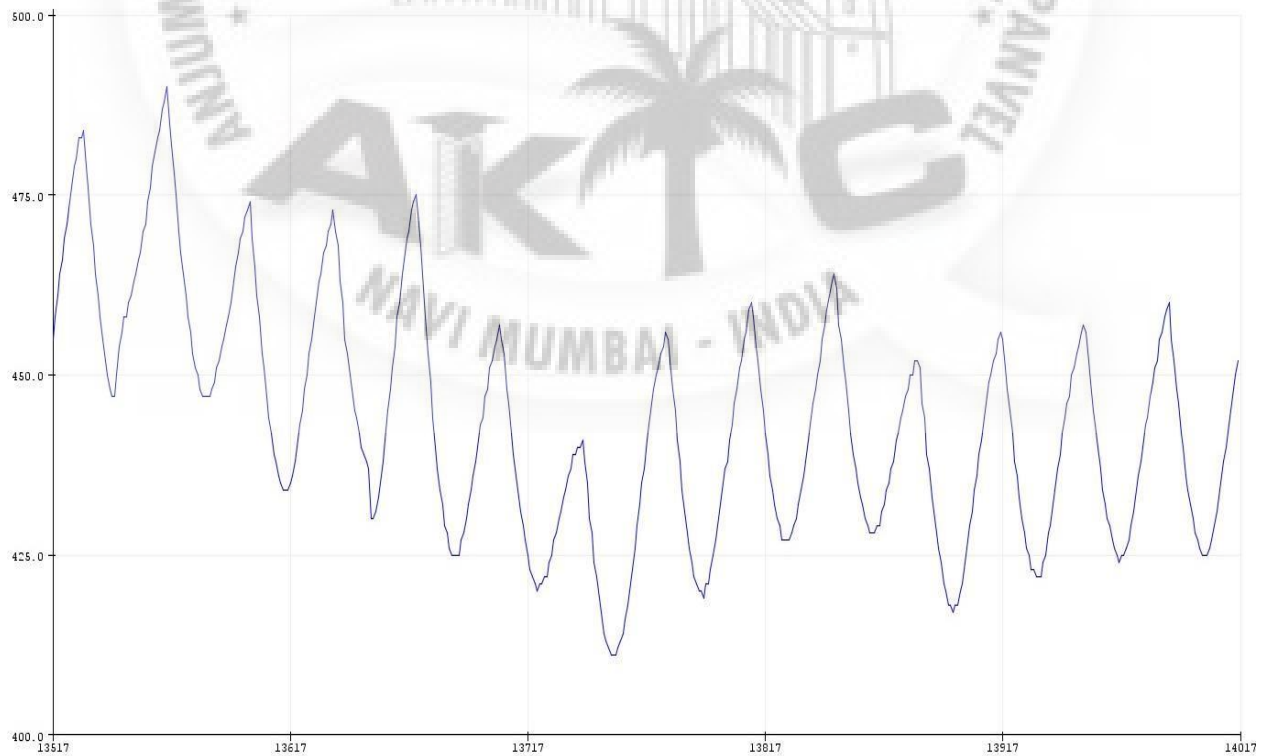

3.5. CODE RELATING ANALOG TO DIGITAL CONVERSION

In the program below, the very first thing that you do will in the setup function is to begin serial communications, at 9600 bits of data per second, between your board and your computer with the line:

```
Serial.begin(9600);
```

Next, in the main loop of your code, you need to establish a variable to store the resistance value (which will be between 0 and 1023, perfect for an int datatype) coming in from your potentiometer:

```
int sensorValue = analogRead(A0);
```

To change the values from 0-1023 to a range that corresponds to the voltage the pin is reading, you'll need to create another variable, a float, and do a little math. To scale the numbers between 0.0 and 5.0, divide 5.0 by 1023.0 and multiply that by sensorValue :

```
float voltage = sensorValue * (5.0 / 1023.0);
```

Finally, you need to print this information to your serial window as. You can do this with the command Serial.println() in your last line of code:

```
Serial.println(voltage)
```

Now, when you open your Serial Monitor in the Arduino IDE (by clicking on the icon on the right side of the top green bar or pressing Ctrl+Shift+M), you should see a steady stream of numbers ranging from 0.0 - 5.0. As you turn the pot, the values will change, corresponding to the voltage coming into pin A0.

4. DISCUSSION AND CONCLUSION

4.1. ABOUT SOLAR PANEL AND CONNECTED LOAD

- Solar panel is placed at the top and connected to a load directly. The load may be a led or a voltmeter which could be connected to get the exact voltage which depends on the intensity of light falling on the panel and the position of the tracker.
- Concentrated solar photovoltaics have optics that directly accept sunlight, so solar trackers must be angled correctly to collect energy. All concentrated solar systems have trackers because the systems do not produce energy unless directed correctly toward the sun.
- The solar panel is just a mere device to accept the light radiation which is purely controlled by LDR sensors and the load connected depends upon the rating of the panel used.

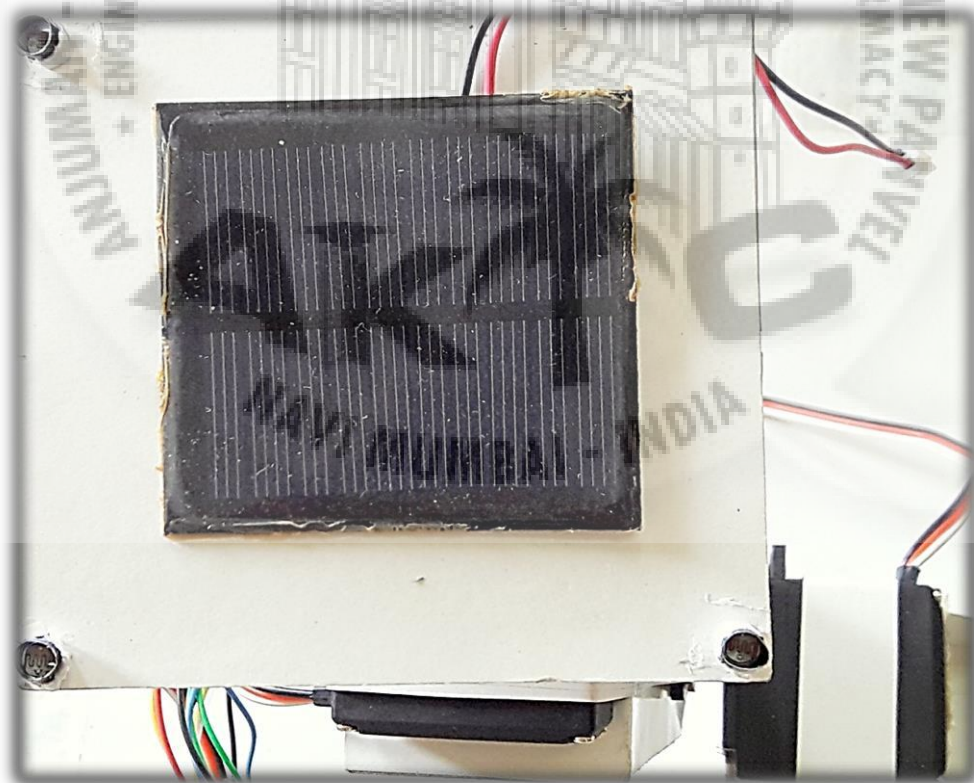

4.2. DUAL AXIS MOVEMENT OF SOLAR TRACKER

- The dual axis solar tracker is device which senses the light and positions towards the maximum intensity of light. It is made in such a way to track the light coming from any direction.
- To simulate the general scenario of the Sun's movement, the total coverage of the movement of the tracker is considered as 120° in both the directions.
- The initial position of both the servo motors are chosen at 90° i.e, for east-west servo motor as well as for north-south servo motor.
- The position of the tracker ascends or descends only when the threshold value is above the tolerance limit.

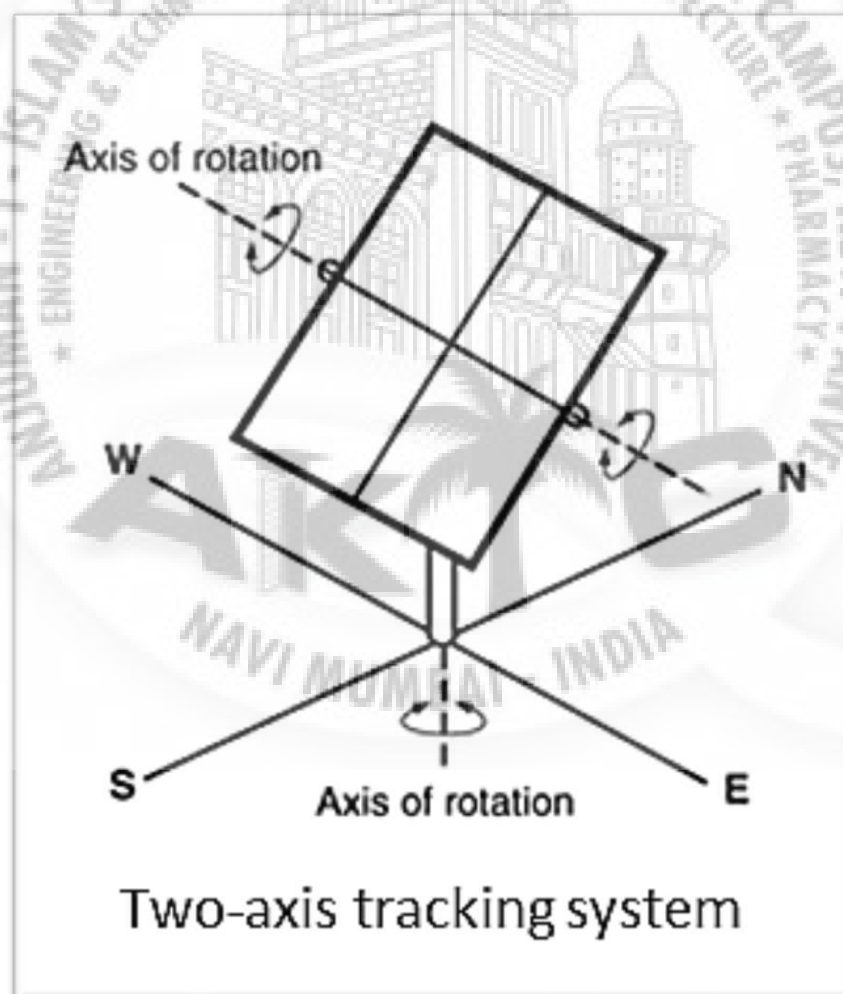

Relation between solar panel misalignment and direct power loss:

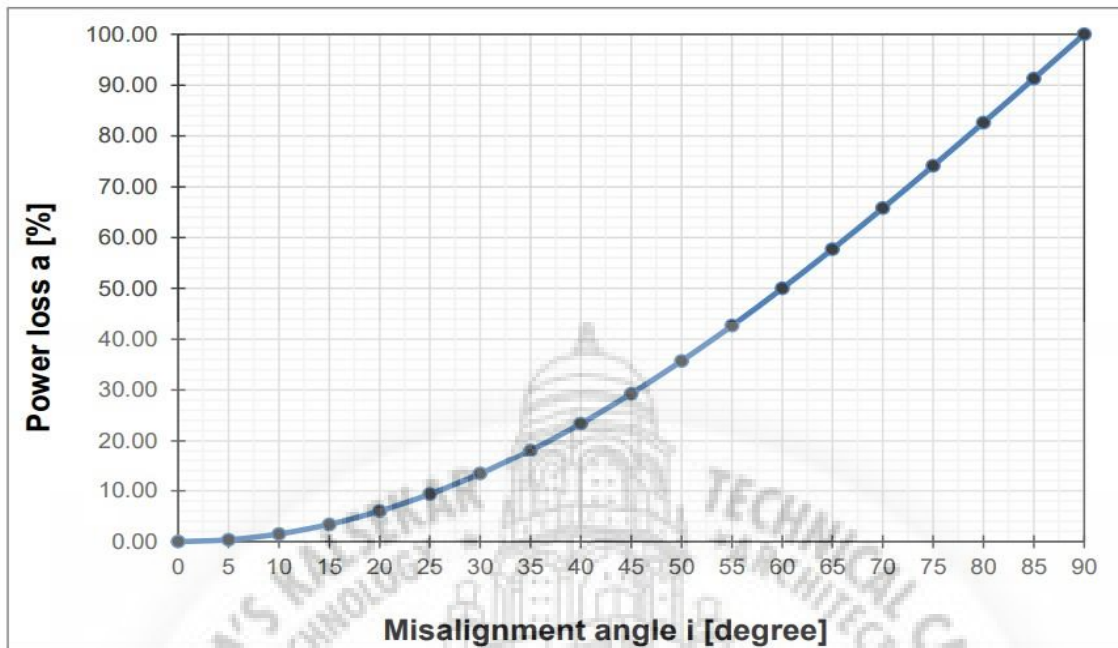

Approximation of power output (red line) compared to maximum output (blue line) for a fix mounted solar module:

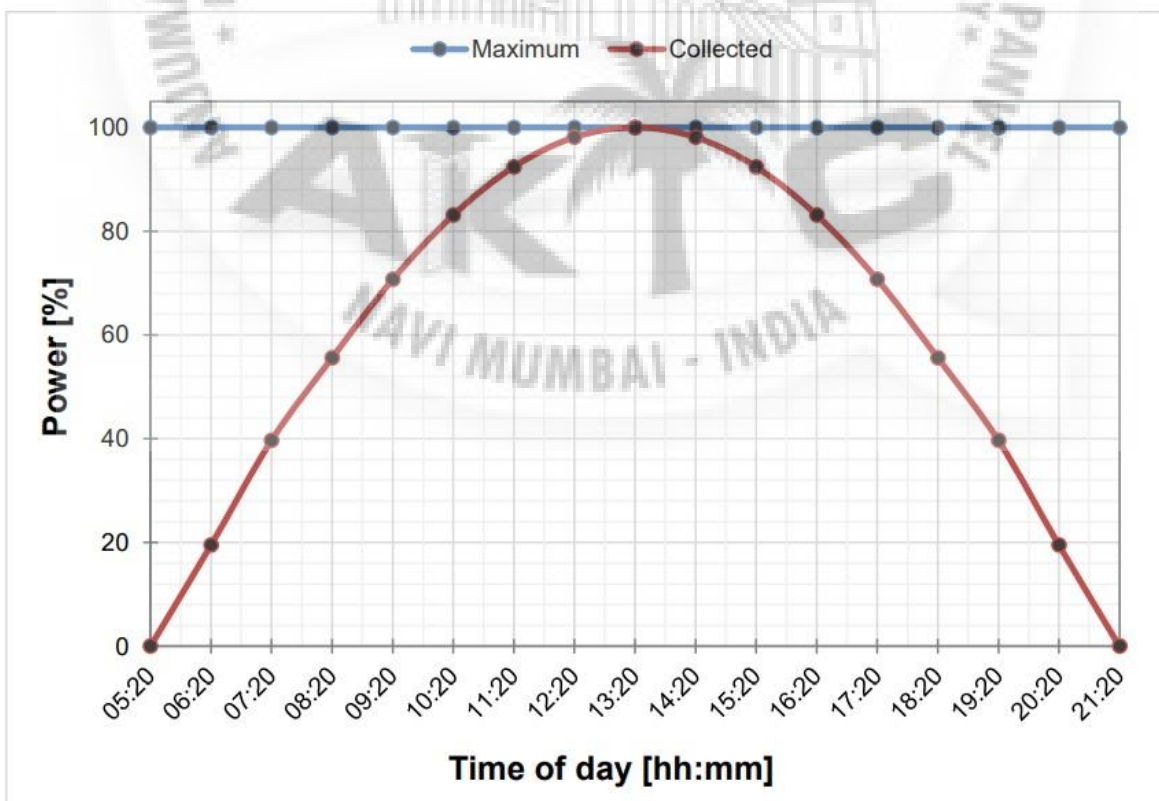

4.3. BENEFITS AND DEMERITS OF SOLAR ENERGY

There are several benefits that solar energy has and which make it favorable for many uses.

Benefits:

- Solar energy is a clean and renewable energy source.
- Once a solar panel is installed, the energy is produced at reduced costs.
- Whereas the reserves of oil of the world are estimated to be depleted in future, solar energy will last forever.
- It is pollution free.
- Solar cells are free of any noise. On the other hand, various machines used for pumping oil or for power generation are noisy.
- Once solar cells have been installed and running, minimal maintenance is required. Some solar panels have no moving parts, making them to last even longer with no maintenance.
- On average, it is possible to have a high return on investment because of the free energy solar panels produce.
- Solar energy can be used in very remote areas where extension of the electricity power grid is costly.

Demerits:

- Solar panels can be costly to install resulting in a time lag of many years for savings on energy bills to match initial investments.
- Generation of electricity from solar is dependent on the country's exposure to sunlight. That means some countries are slightly disadvantaged.
- Solar power stations do not match the power output of conventional power stations of similar size. Furthermore, they may be expensive to build.
- Solar power is used for charging large batteries so that solar powered devices can be used in the night. The batteries used can be large and heavy, taking up plenty of space and needing frequent replacement.

FINALLY,

As the merits are more than the demerits, the use of solar power is considered as a clean and viable source of energy. The various limitations can be reduced through various ways.

4.4. OBSERVATIONS AND RESULT

WHAT WE HAVE OBSERVED....

In this Dual Axis Solar Tracker, when source light falls on the panel, the panel adjusts its position according to maximum intensity of light falling perpendicular to it.

The objective of the project is completed. This was achieved through using light sensors that are able to detect the amount of sunlight that reaches the solar panel. The values obtained by the LDRs are compared and if there is any significant difference, there is actuation of the panel using a servo motor to the point where it is almost perpendicular to the rays of the sun.

This was achieved using a system with three stages or subsystems. Each stage has its own role.

The stages were;

- An input stage that was responsible for converting incident light to a voltage.
- A control stage that was responsible for controlling actuation and decision making.
- A driver stage with the servo motor. It was responsible for actual movement of the panel.

The input stage is designed with a voltage divider circuit so that it gives desired range of illumination for bright illumination conditions or when there is dim lighting. The potentiometer was adjusted to cater for such changes. The LDRs were found to be most suitable for this project because their resistance varies with light. They are readily available and are cost effective. Temperature sensors for instance would be costly.

The control stage has a microcontroller that receives voltages from the LDRs and determines the action to be performed. The microcontroller is programmed to ensure it sends a signal to the servo motor that moves in accordance with the generated error.

The final stage was the driving circuitry that consisted mainly of the servo motor. The servo motor had enough torque to drive the panel. Servo motors are noise free and are affordable, making them the best choice for the project.

4.5. CONCLUSION

In this 21st century, as we build up our technology, population & growth, the energy consumption per capita increases exponentially, as well as our energy resources (*e.g.*, fossils fuels) decrease rapidly. So, for sustainable development, we have to think alternative methods (utilization of renewable energy sources) in order to fulfil our energy demand.

In this project, Dual Axis Solar Tracker, we've developed a demo model of solar tracker to track the maximum intensity point of light source so that the voltage given at that point by the solar panel is maximum. After a lot of trial and errors we've successfully completed our project and we are proud to invest some effort for our society. Now, like every other experiment, this project has couple of imperfections.

- (i) Our panel senses the light in a sensing zone, beyond which it fails to respond.
- (ii) If multiple sources of light (*i.e.*, diffused light source) appear on panel, it calculates the vector sum of light sources & moves the panel in that point.

This project was implemented with minimal resources. The circuitry was kept simple, understandable and user friendly.

4.6. RECOMMENDATION

Though we have performed our work in much efficient way. There is still room for improvement for this system and it is hoped that further study can be carried out to further develop the system.

- Use higher motors with large torque value for larger panel size.
- It will be better to use geographical equation algorithm for the real timing tracking.
- Use diffused reflection phenomenon.

4.7. APPLICATIONS

- Dual axis trackers generate more Electricity than their stationary counterparts due to increased direct exposure to solar rays. This increase can be as much as 10% to 25% depending on the geographic location of the system.
- Dual axis trackers generate more electricity in roughly the same amount of space needed for fixed tilt systems making them ideal for optimizing land usage.
- Dual axis trackers can be used for small, medium and large-scale power generation.
- It can be used for power generation at remote places.
- It can be as domestic power backup power System.
- It may be used in water treatment technologies and solar heating.
- As we know that the sun produces both heat and light energy in the form of electromagnetic radiation. When it comes to thermal use, it is mainly used for water heating and heat sources to different types of concentrator for various heat application.

This are discussed below:

1) WATER HEATER

Solar water heaters also called solar domestic hot water systems, can be a cost-effective way to generate hot water for your home. They can be used in any climate, and the fuel they use: sunshine, is free. Working of solar water heating systems include storage tanks and solar collectors. There are two types of solar water heating systems: active, which have circulating pumps and controls, and passive, which don't.

i. Active solar water heating systems

Active systems use one or more pumps to circulate water and/or heating fluid in the system.

Though slightly more expensive, active systems offer several advantages.

There are two types of active solar water heating systems:

- Direct circulation systems

Pumps circulate household water through the collectors and into the home.

They work well in climates where it rarely freezes.

- Indirect circulation systems

Pumps circulate a non-freezing, heat-transfer fluid through the collectors and a heat exchanger. This heats the water that then flows into the home. They are popular in climates prone to freezing temperatures.

ii. Passive solar water heating systems

Passive solar water heating systems are typically less expensive than active systems, but they're usually not as efficient. However, passive systems can be more reliable and may last longer.

There are two basic types of passive systems:

- Integral collector - storage passive systems

These work best in areas where temperatures rarely fall below freezing. They also work well in households with significant daytime and evening hot-water needs.

- Thermosyphon systems

Water flows through the system when warm water rises as cooler water sinks. The collector must be installed below the storage tank so that warm water will rise into the tank. These systems are reliable, but contractors must pay careful attention to the roof design because of the heavy storage tank. They are usually more expensive than integral collector-storage passive systems.

4.7. LIMITATIONS

- The reading taken will be compromised by the weather.
- The readings and tracking system are as good as the calibration of low-cost materials to be used in the system.

4.8. SCOPE OF WORK IN THE PROJECT

The solar project was implemented using two servo motors. The choice was informed by the fact that the motor is fast, can sustain high torque, has precise rotation within limited angle and does not produce any noise. The Arduino IDE was used for the coding. Kolkata has coordinates of 22.5726°N , 88.3639°E and therefore the position of the sun will vary in a significant way during the year. In the tropics, the sun position varies considerably during certain seasons. There is the design of an input stage that facilitates conversion of light into a voltage by the light dependent resistors, LDRs. There is comparison of the two voltages, then the microcontroller uses the difference as the error. The servo motor uses this error to rotate through a corresponding angle for the adjustment of the position of the solar panel until such a time that the voltage outputs in the LDRs are equal. The difference between the voltages of the LDRs is received as analog readings.

Function of the processor: The analog readings are converted to integer values by ADC input ports which is compared in order to get the difference value for motor movement.

The difference is transmitted to the servo motor and it thus moves to ensure the two LDRs are an equal inclination. This means they will be receiving the same amount of light, and the Solar panel will receive the sunlight at 90° , (the plane of PV panel will make an angle 90° with the Sun, and the perpendicular drawn on the plane makes an angle 0° with the Sun, to ensure maximum illumination: Lambert's cosine Law). The procedure is repeated throughout the day. Tracker systems work on two simple principles together. One being, the normal principle of incidence and reflection on which our tracker works and the other is the principle on which the solar (PV) panel works, which will produce electricity. Both these principles can be combined and as a result of which it can produce nearly double the output that the panel specifies normal

APPENDIX

SPECIFICATIONS OF THE HARDWARE REQUIREMENT

✓ FEATURES OF ARDUINO UNO

1) Microcontroller: **ATMEGA 328P**

The Atmel®picoPower®ATmega328/P is a low-power CMOS 8-bitmicrocontroller based on the AVR® enhanced RISC architecture.

FEATURES:

High Performance, Low Power Atmel®AVR® 8-Bit Microcontroller Family

- Advanced RISC Architecture
 - 131 Powerful Instructions
 - Most Single Clock Cycle Execution
 - 32 x 8 General Purpose Working Registers
 - Fully Static Operation
 - Up to 20 MIPS Throughput at 20MHz
 - On-chip 2-cycle Multiplier
- High Endurance Non-volatile Memory Segments
 - 32KBytes of In-System Self-Programmable Flash program

Memory

- 1KBytes EEPROM
- 2KBytes Internal SRAM
- Write/Erase Cycles: 10,000 Flash/100,000 EEPROM
- Data Retention: 20 years at 85°C/100 years at 25°C (1)
- Optional Boot Code Section with Independent Lock Bits
 - In-System Programming by On-chip Boot Program
 - True Read-While-Write Operation.

– Programming Lock for Software Security

- 2) Operating Voltage: 5v
- 3) Input Voltage (recommended): 7-12V
- 4) Input Voltage (limits): 6-20V
- 5) Digital I/O Pins: 14 (of which 6 provide PWM output)
- 6) Analog Input Pins: 6
- 7) DC Current per I/O Pin: 40 mA
- 8) DC Current for 3.3V Pin: 50 mA
- 9) Flash Memory: 32 KB of which 0.5 KB used by bootloader
- 10) SRAM: 2 KB (ATmega328)
- 11) EEPROM: 1 KB (ATmega328)
- 12) Clock Speed: 16 MHz

✓ **SOLAR PANEL**

- 1) Maximum Voltage: 4volts (under load)
- 2) Maximum Voltage: 4.8volts (no load)
- 3) Rated Current: 100mA
- 4) Dimension: 6 cm (L) x 6 cm (W) x 0.25 cm (t)
- 5) Maximum Wattage: 0.5W

✓ SERVO MOTOR

MODULATION	ANALOG
Torque	4.8V :3.17 kg-cm 6.0V :4.10 kg-cm
Speed	4.8V :0.23 sec/60° 6.0V :0.19 sec/60°
Weight	37.2 g
Dimensions	39.9mm x 20.1mm x 36.1 mm
Motor Type	3 pole Ferrite
Gear Type	Plastic
Rotation/Support	Bushing
Operating angle	45 Deg.one side pulse travelling 400 μ s
Pulse cycle	30 MS
Pulse width	500-300 μ s
Connector Type	J

✓ LIGHT DEPENDENT RESISTOR

Photoresistor 5mm GL5516 LDR Photo Resistors Light-Dependent Resistor Model: GL5516

- Size: 5mm x 2mm
- Maximum Voltage: 150 Volt DC
- Maximum Wattage: 90mW
- Operating Temperature: (-30 to +70) °C
- Spectral Peak: 540nm
- Light Resistance (at 10 Lux): 5-10 k Ω
- Dark Resistance: 0.5 M Ω
- Response time: 20ms (Rise), 30ms (Down)
- Resistance Illumination: 4

AVENUES FOR FURTHER WORK

With the available time and resources, the objective of the project was met. The project is able to be implemented on a much larger scale. For future projects, one may consider the use of more efficient sensors, which should also be cost effective and consume little power. This would further enhance efficiency while reducing costs. If there is the possibility of further reducing the cost of this project, it would help a great deal. This is because whether or not such projects are embraced is dependent on how cheap they can be. Shading has adverse effects on the operation of solar panels. Shading of a single cell will have an effect on the entire panel because the cells are usually connected in series. With shading therefore, the tracking system will not be able to improve efficiency as is required.

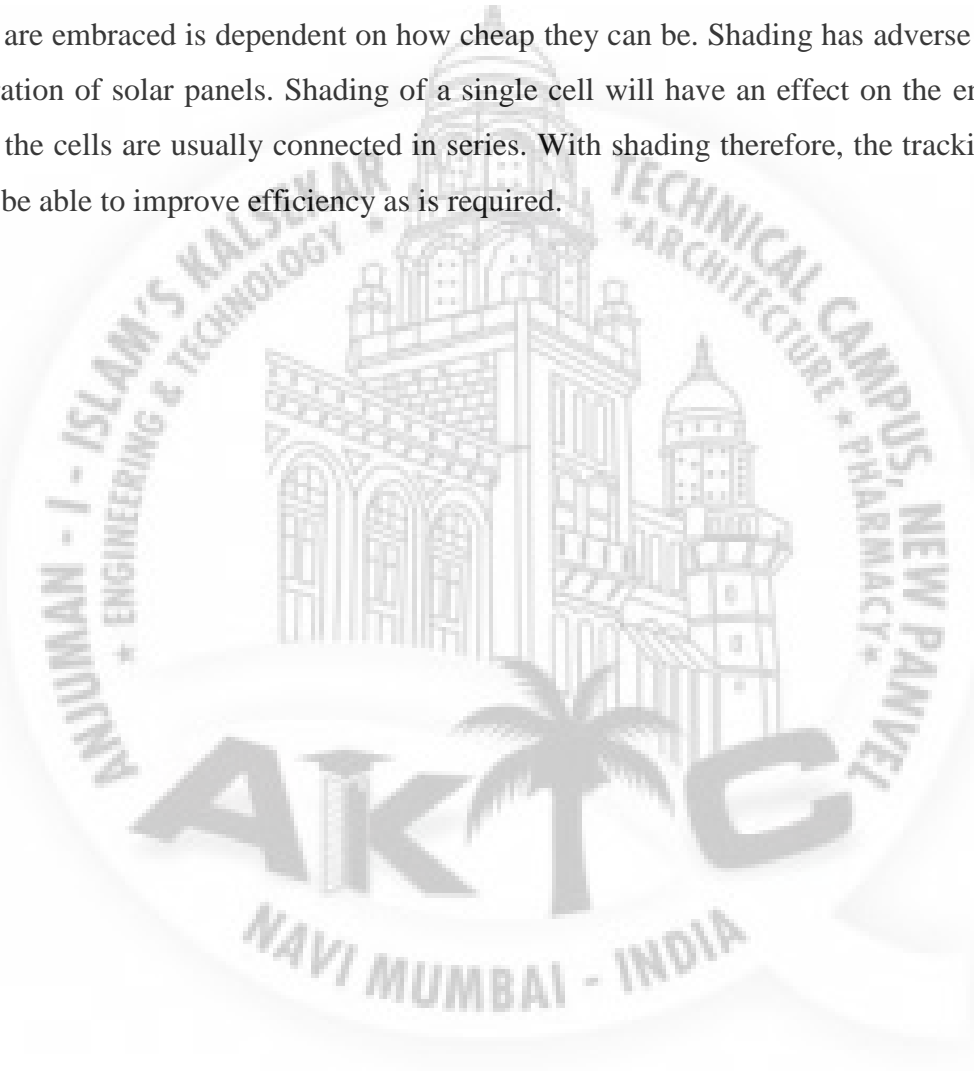

REFERENCES

- [1] Solar Tracking Hardware and Software by *Gerro J Prinsloo*
- [2] Design and Implementation of a Sun Tracker with a Dual-Axis Single Motor
“*Jing-Min Wang and Chia-Liang Lu*”
- [3] Sensors and Transducers...Second Edition...”*D.Patranabis*”
- [4] Atmel ATmega48A/PA/88A/PA/168A/PA/328/P-datasheet
- [5] Utilisation of Electrical Power. Author, *Er. R. K. Rajput*.
- [6] Arduino Programming Book. Author, *Brian W. Evans*

