



Knowledge Resource & Relay Centre (KRRC)

AIKTC/KRRC/SoET/ACKN/QUES/2022-23/

Date: 25/01/23

School: SoET-REV. C-SCHEME Branch: ALL BRANCHES SEM: II

To,
Exam Controller,
AIKTC, New Panvel.

Dear Sir/Madam,

Received with thanks the following Semester/Unit Test-I/Unit Test-II (Reg./ATKT) question papers from your exam cell:

Sr. No.	Subject Name	Subject Code	Format		No. of Copies
			SC	HC	
1	Engineering Mathematics-II	FEC201		✓	
2	Engineering Physics-II	FEC202		✓	
3	Engineering Chemistry-II	FEC203		✓	
4	Engineering Graphics	FEC204		✓	
5	C programming	FEC205		✓	
6	Professional Communication and Ethics- I	FEC206		✓	

Note: SC – Softcopy, HC - Hardcopy

(Shaheen Ansari)
Librarian, AIKTC

7/12/22

30am

Sem - II - C-19 KT

R-19

(Time: 3 Hours)

Max. Marks: 80

- N.B:** 1) Question No.1 is **COMPULSORY**
 2) Answer **ANY THREE** questions from **Q. 2 to Q. 6**
 3) Figures to the right indicate full marks

Q.1 a) Solve 5

$$(2x - 2x^3y^2)dy + (x^2y^3 + 2y)dx = 0$$

b) Show that 5

$$\int_0^{\pi/2} \sqrt{\sin \theta} d\theta * \int_0^{\pi/2} \frac{d\theta}{\sqrt{\sin \theta}} = \pi$$

c) Evaluate 5

$$\int_0^{\log 2} \int_0^x \int_0^{x-y} e^{x+y+z} dz dy dx$$

d) Solve 5

$$(D^2 + 3D + 2)y = \sin(e^x)$$

Q.2 a) Evaluate $\int_0^1 \frac{x^a - 1}{\log x} dx$ using DUIS rule 6

b) Change the order of Integration 6

$$\int_0^a \int_{\sqrt{a^2-x^2}}^{x+3a} f(x, y) dy dx$$

c) Solve by the method of variation of parameters 8

$$\frac{d^2y}{dx^2} + y = \sec x \tan x$$

Q.3 a) Evaluate $\iiint dx dy dz$ over the solid region of paraboloid $x^2 + y^2 = 4z$ cut off by the plane $z = 4$ 6

b) Solve 6

$$y^4 dx = \left(\frac{1}{x^{3/4}} - xy^3 \right) dy$$

c) Prove that 8

$$\left(\int_0^3 \frac{x^{3/2}}{\sqrt{3-x}} dx \right) * \left(\int_0^1 \frac{1}{\sqrt{1-x^{1/4}}} dx \right) = \frac{432}{35} \pi$$

- Q.4 a) Solve 6
 $[y \sin(xy) + xy^2 \cos(xy)]dx = -[x \sin(xy) + x^2 y \cos(xy)]dy$
- b) Change the order of the integration and evaluate 6

$$\int_0^1 \int_{-\sqrt{y}}^{-y^2} xy \, dx \, dy$$
- c) Solve 8
 $(D^2 + 2)y = e^x \cos x + x^2 e^{3x}.$
- Q.5 a) Solve $x \sin x \, dy + (xy \cos x - y \sin x - 2)dx = 0$ 6
- b) Evaluate $(D^2 + 1)y = 2^x + \sin x \sin 2x$ 6
- c) Using Polar co-ordinates, evaluate $\iint \frac{(x^2 + y^2)^2}{x^2 y^2} \, dx \, dy$ over the area 8
 common to the circles $x^2 + y^2 = ax$ and $x^2 + y^2 = by$, $a > 0, b > 0$
- Q.6 a) Find the length of the cardioid $r = a(1 - \cos \theta)$ lying outside the circle 6
 $r = a \cos \theta$
- b) Evaluate $\iint xy \, dx \, dy$ over the region bounded by the curves 6
 $y = 4x, x + y = 3, y = 0$ and $y = 2$
- c) Evaluate $\iiint (x^2 + y^2 + z^2) \, dx \, dy \, dz$ over the positive octant of the 8
 sphere $x^2 + y^2 + z^2 = 4$
-

KT
9/12/22

R-19 F.E.
Sem - II

Time : 2 Hours

Total Marks : 60

N.B :

- 1) Question number 1 is compulsory
- 2) Attempt any three questions from Q2 to Q6
- 3) Use suitable data wherever required
- 4) Figures to the right indicate full marks for that question

Q.1 Attempt any five Questions out of seven Questions (3 marks each)

- a) Explain following terms i) Spontaneous emission ii) Population Inversion .
- b) What is nanotechnology ? What is its significance ?
- c) Compare Laser source with ordinary optical source
- d) What is Optical Grating and Grating element ?
- e) What are inertial and Non inertial frames of references ?
- f) What are transducers ? what is their significance of Transducer in modern technology
- g) State applications of the Lasers in Industry and medicine .

Q.2 (a) Explain physical significance of Divergence and Curl of a vector field with suitable Example ? (5)

(b) With appropriate schematic diagram explain Method of reconstruction of the Hologram ? (5)

(c) Find the fractional increase in mass of a particle moving at velocity given by $0.2c$ and velocity of particle when mass of particle will be 1.5 times it's rest mass (5)

Q.3 (a) Explain with neat diagram construction of Nd-Yag laser (5)

(b) Explain the relativistic phenomenon of Time dilation with appropriate mathematical derivation . (5)

(c) Explain the use of PT100 as a industrial thermometer (5)

Q. 4 (a) A glass clad fibre is made with core glass of refractive index 1.5 and the cladding is doped to give a fractional index difference of 0.0005
Find :

- (i) Cladding Index
- (ii) The critical internal reflection angle
- (iii) The external critical reflection angle
- (iv) The numerical aperture (5)

(b) Draw the Schematic diagram of Scanning Electron Microscope (SEM) and explain it's working . (5)

(c) Derive Maxwell's First equation and state its significance . (5)

- Q. 5 (a) Plane waves of wavelength 600nm fall normally on single slit of width 0.2mm. Calculate the total angular width of the central maximum and also the linear width as observed on screen placed 2 cm away. (5)
- (b) What is difference between Bottom up and Top down approach of synthesis of nanoparticles. (5)
- (c) What is resolving power of the grating? Discuss the factors on which it is dependent? What is significance of resolving power of grating? (5)
- Q6. (a) With appropriate diagram explain concept of Pressure sensing by Capacitive method. (5)
- (b) Find maximum value of resolving power of a diffraction grating 3 cm wide having 5000 lines per cm, if the wavelength of light used is 589 nm. (5)
- (c) How will you state Faraday's law in differential (in point) form explain with appropriate derivation. (5)
-

Sem - II CBCS - C19 - KT

(2 Hours)

[Total Marks: 60]

Note:

1. Question No.1 is compulsory
2. Attempt any Three Questions from the remaining Five Questions
3. Figures to the right indicate full marks
4. Atomic Weights: C = 12, H = 1, O = 16, N = 14, S = 32, Cl = 35.5

- Q1 Attempt any Five of the following: 15
- a. What are fuels? Give characteristics of good fuel.
 - b. How does position of metal in galvanic series affect corrosion.
 - c. Explain 'Prevention of waste' principle in green chemistry.
 - d. Define Spectroscopy and Electromagnetic spectrum.
 - e. Give the principle of cathodic protection. What are the two types of cathodic protection?
 - f. A cell is constructed from Ni / Ni⁺² and Cu⁺² / Cu half cells. Given E⁰Ni = - 0.257 V and E⁰Cu = 0.337 V. Find out the standard potential of the cell.
 - g. A sample of coal has the following composition by mass: C = 85%, H = 6%, O = 8%, S = 0.5% and Ash = 0.5%. Calculate HCV using Dulong's Formula.
- Q2a What is Electrochemical corrosion? Explain Hydrogen evolution mechanism with the help of diagram. 6
- b Define Green Chemistry. Calculate the percentage atom economy for the following reaction with respect to allyl chloride. 5
- $$\text{CH}_3\text{-CH=CH}_2 + \text{Cl}_2 \rightarrow \text{Cl-CH}_2\text{-CH=CH}_2 + \text{HCl}$$
- Propene Allyl chloride
- c What is knocking. Explain the role of anti-knocking agents. 4
- Q3a What is oxidation corrosion. Name the different types of oxide layer formed and state which oxidelayers are non-protective in nature. Explain with suitable examples. 6
- b 3.2 gm of coal in Kjeldahl's experiment evolved NH₃ gas was absorbed in 40 ml of 0.5 N H₂SO₄. After absorption the excess acid required 16 ml of 0.5N NaOH for complete neutralization. 2.5 gms of coal sample in quantitative analysis gave 0.42 gm BaSO₄. Calculate the % N and S. 5
- c What is Electrochemistry? Differentiate between Electrolytic cell and Galvanic cell. 4
- Q4a Proximate analysis consist of determinations of which contents in the coal. Calculate the weight of air required for complete combustion of 1Kg coal containing C=65%, H=4%, O=5%, S=2%, N=4%, moisture=10% and remaining ash. 6
- b Explain conventional and green route method of manufacturing of Carbaryl. By this method which principle of Green Chemistry is shown? 5
- c How is the rate of corrosion influenced by: 4
- (i) pH of the medium
 - (ii) Relative areas of cathode and anode parts.

- Q5a Give in tabular form the relation between electromagnetic spectrum, types of spectroscopy and corresponding energy changes. 6
- b Explain trans-esterification method for synthesis of bio- diesel. Mention advantages of Bio-diesel. 5
- c What are metallic coatings? Distinguish between galvanizing and tinning. 4
- Q6a What are reference electrodes? Give construction and working of any one secondary reference electrode. 6
- b (i) What is unleaded petrol? Give the advantages of oxygenates. 5
(ii) Define Octane and Cetane number, also give its significance.
- c What are selection rules? Explain any two selection rules. 4
-

Sem-II-CBC-KT

Time:3 Hrs

Max Marks:60

Note :

- Solve any FOUR questions.
- All dimensions are in mm.
- Use First Angle Method Of Projection.
- Assume Suitable Dimension If Necessary.

Q.1 Following figure shows the pictorial view of an object. Draw

- | | | |
|------|--|-----|
| i) | Sectional front view along section A-A | [5] |
| ii) | Top view. | [4] |
| iii) | Right Hand Side view | [4] |
| iv) | Insert at least 10 dimensions | [2] |

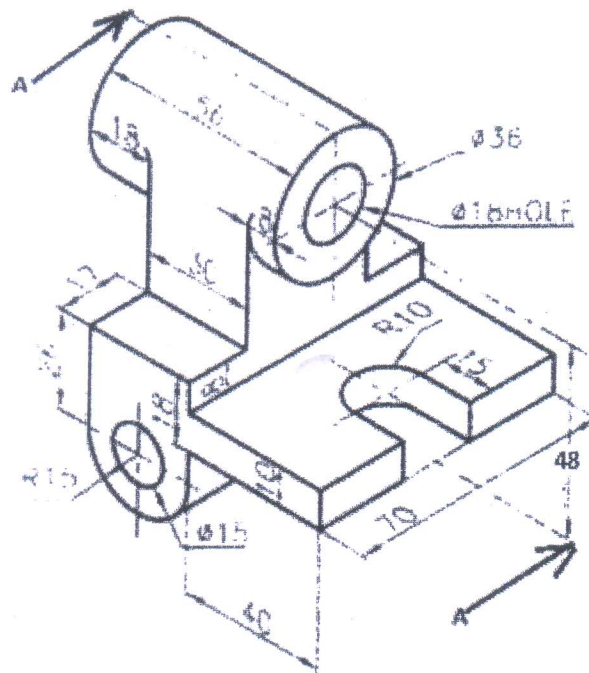

Q.2 (a) A cylinder of diameter 50 and axis 65 mm long is lying on H.P on its curved surface with axis inclined at 45° to V.P and parallel to HP. Draw the projections of cylinder. [6]

(b) Draw the isometric view of the object whose FV and TV are as given below. [9]

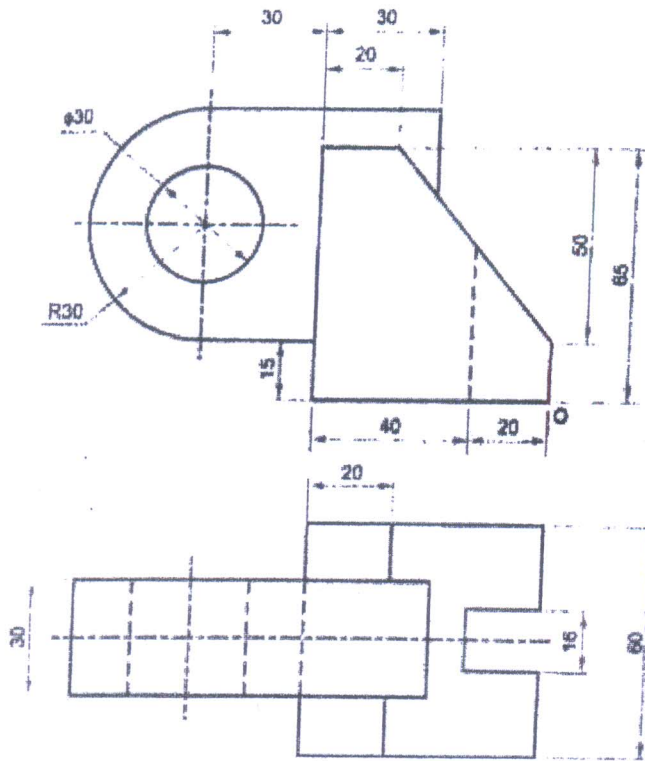

Q.3 (a) The pictorial view of a machine part is shown in following figure. Draw

- i) Front view from the direction "X"
- ii) Top view
- iii) Insert at least 6 Dimensions.

[4]
[4]
[1]

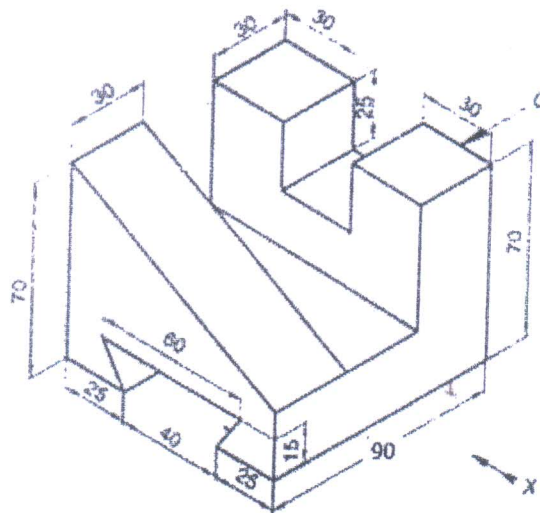

- (b) One end of a string, AB, of length 140mm is wound round a disc of diameter 50mm by keeping one end, A, fixed on the disc and keeping the string always tight. Draw the locus traced by the other end of the string B. Name the curve. [6]

- Q.4 A pentagonal pyramid, side of base 35 mm and axis 65mm long is resting on one of its corners on HP such that one of the triangular surfaces is parallel to HP and perpendicular to VP. Draw the projections of solid when the base edge containing that triangular surface is parallel to both HP and VP. The apex of the pyramid is being nearer to observer [15]

- Q.5 One end P of a line PQ is on HP and 25 mm in-front of VP while other end Q is on VP and 50mm below HP. Draw projections of line PQ and find its inclinations with HP and VP if the true length of PQ is 70mm. [15]

- Q.6 (a) The FV and TV of an object is shown below. Draw the Isometric view of the object. [8]

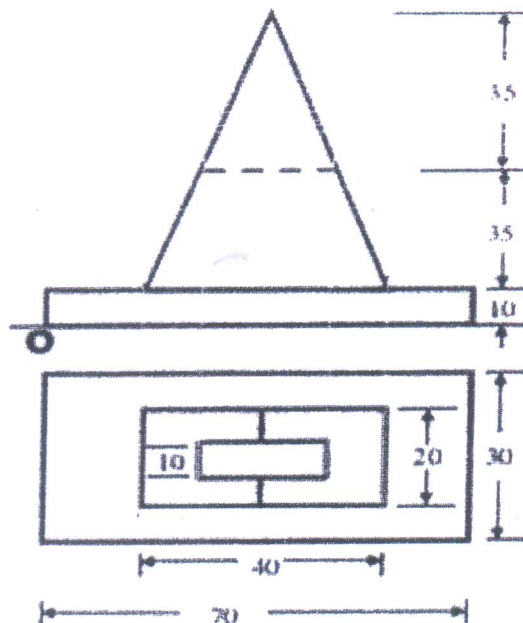

- (b) A hexagonal prism of side of base 35 mm and axis 65mm long is resting on one of its base edges on HP such that the base of the prism is inclined 45 degrees to HP and axis parallel to VP. Draw the projections of prism. [7]

All Branch

Sem-II-C9-KT

Time: 2 hour

Max. Marks: 60

NB: 1) Question No.1 is compulsory.

2) Attempt any three questions from question no. 2 to 6.

Q1 (15 marks)

Solve any Three out of the following (5 marks each)

- A Explain what is flowchart ? Explain different symbols used in flowchart.
- B Explain following library functions with proper example.
1. pow() 2. ceil() 3. floor() 4. sqrt()
Write a program to print following pattern after accepting number of rows from user.
- C

```
1
2 3
4 5 6
7 8 9 10
```
- D Differentiate between Structure and Union.
- E Explain conditional Operator with proper example.

Q2 (15marks)

- A What is Recursion? Write a program to find GCD of two numbers using recursive function. 6M
- B Explain Different data type modifiers available in C language. 5M
- C Write a program to find length of a string without using standard library function. 4M

Q3 (15marks)

- A Write a program to display all prime numbers from 100 to 500. 6M
- B Write a program in C to find average of N elements entered by user using an array. 5M
- C Explain with example left and right shift bitwise operators. 4M

Q4 (15marks)

- A Write a program to store information of 10 students using Structure. Information include Roll, name, marks of a student 6M
- B Write a C program to check whether user entered string is palindrome or not. 5M

C Write the output for the following code. 4M
#include<stdio.h>
void main()
{
 int i;
 for(i=0;i<5i++);
 printf("%d",i);
 printf("\nhi");
}

Q5
(15marks)

- A Write a program to find largest of three numbers. 6M
- B Differentiate between entry and exit controlled loop. 5M
- C Explain the need of Function Prototype with example. 4M

Q6
(15marks)

- A Write a program to check whether square matrix is symmetric or not. 6M
- B Write an algorithm and draw flowchart to check whether given number is prime number or not. 5M
- C Explain with syntax and example multi-way branching statement 4M

Sem - II - C - A - K T

FE Sem II
20/6/2023

Duration: 1Hrs.30 Mint

Total Marks: 40

NB: 1. Q1. is compulsory.

2. Attempt any Three out of the remaining Five questions.

3. Figures to the right indicate full marks.

4. Answers to the sub questions should be grouped together.

Q1 Answer the following questions:

A. Write short note on Postulates/ Hallmarks of effective communication. (10)

B. Objectives of communication. (03)

C. Define Communication and discuss the cycle of communication with the help of a diagram and suitable example. (05)

Q2. Answer any 2 out of 3 questions:

A. (i) A friend of yours is preparing for an interview. Suggest him some aspects of Kinesics that he needs to follow for success. (10)

(ii) Classify the following instructions as Caution, Warning, Danger and Note: (03)

a) Always use good quality printing paper for better results. (02)

b) Do not touch connections with wet hands.

c) Do not expose camera lens to direct sunlight.

d) Never extend any part of the body through the elevator gate when it is in motion.

B. What is a Grapevine? Discuss the merits and demerits of Grapevine in an organization. (05)

C. During the pandemic, your travel agency has taken a hit. You are planning on reviving the business post pandemic. Write a Sales letter offering discounts and other interesting privileges on various tour packages. (05)

Q3 Do as directed:

A. Fill in the blanks: (03)

- 1) _____ is the last component in the process of communication.
- 2) _____ is the process of finding out a particular piece of information while reading
- 3) _____ communication moves on the equal authority level.
- 4) _____ means movement of hand, neck to communicate messages.
- 5) One who sacrifices his life for a cause is called _____.
- 6) The list of spare parts _____ long. (was/were)

B. Match the following:

- | | |
|---------------------|--------------------------------|
| (i) Post Script | (a) No abbreviation |
| (ii) UVW/AC | (b) Not indented paragraphs |
| (iii) Date line | (c) exhibits unplanned content |
| (iv) Complete Block | (d) Identification Mark |
| | (e) Indented Paragraphs |

(02)

C. Identify the barriers in the following situations. How can it be overcome?

(02)

Mr. Ronny had been a successful manufacturer for twenty years. He used glass containers for his products. When a salesman visited him to show a new plastic container which was more durable and which cost less. Mr. Ronny refused to listen to him and mockingly asked the salesman if he knew more about his business than he did.

D. Define: (i) Calculator (ii) Voltmeter (iii) Stapler

(03)

Q4. Answer any 2 out of 3 questions:

A. You had placed a bulk order of children's wear that reached too late after the festival. This resulted in great loss of business. Write a complaint letter to the Garment company about the late delivery of the consignment. Claim for the loss. (Use the Complete Block Format.)

(05)

B. Write short note on: (i) You Attitude (ii) AIDA

(05)

C. Difference between : Technical Writing and Literary Writing

(05)

Q5. Answer any 2 out of 3 questions:

(10)

A. Identify Sender, Receiver, Message, Channel and Feedback in the given statements.

(05)

(i) A student sends through post an application letter to a company and receives a call for an interview.

(ii) The Vice President of an organization instructs the assistant engineer via e-mail to submit his project report within a week. The assistant engineer fails to submit the report.

B. Difference between:

(05)

(i) Caution and Warning

(ii) Technical Descriptions and Instructions

C. Draw Diagrammatic Representation of Complete Block Style.

(05)

Q6. Answer any 2 out of 3 questions:

(10)

Q6 A. Read the following passage and answer the following questions.

(05)

Values are the essence of humanity; values assist a nation live and build her identity. India the mother to all human values enjoys a much-privileged position in the world, thanks to a well-

developed system and defined a set of values that the people here have been practising since ages. Values are in no way hostile to materialistic, technological and scientific progress. They help people live life in peace with themselves, with society and nature. The satellite channels, another manifestation of science, inspire all of their advantages; have been hitting hard at the very root, the foundation of Indian society, i.e., its values. The availability of B.B.C., CNN, Zee TV, Nat Geo, Discovery, etc. in sitting rooms at the click of a button have exposed the Indians, especially the young and impressionable Indians, to the culture and practices which vitiate and pollute the young and old alike.

The majority of the programmes beamed on the satellite channels are based on fantasy. They suggest infeasible solutions to day-to-day life problems. This entices and lures people to succeed by hook or by crook. Moreover, programmes such as W.W.F. make the viewers aggressive, callous and 'violence-crazy'. In addition to it, the lifestyle shown in various programmes stand in stark contrast to the one appreciated and suggested by our values. The new generation of youth is definitely being impressed with the alien culture. Additionally, long hours of television viewing have led to our younger generation becoming couch potatoes. Also, the time spent on social interaction, the most educative and informative interaction is decreasing. Consequently, all the values — social as well as moral — are now going haywire with the blatant display on various satellites channels.

It is now imperative that the parents should take up the duty of minimizing the exposure of the children to the 'idiot box'. They should owe this as the dutiful citizens of a nation. Also, the government should ensure a strict censorship of these channels so that our principles, values and culture are not eroded, damaged and spoiled.

1. How are values the essence of humanity?
2. Why does India gain a special place in the world?
3. How are Indian values attacked?
4. How are children affected by satellite channels?
5. **Choose the word that means the same as:**

(a) attracts

(i) entices (ii) ensure (iii) vitiate (iv) lures

(b) enemy

(i) hostile (ii) alien (iii) callous (iv) crook

Q6 B. Write a set of clear and precise instructions in order to make an ATM withdrawal with appropriate usage of special notations. (05)

Q6 C. Explain any Two Psychological Barriers. (05)
