



AIKTC/KRRC/SoET/ACKN/QUES/2022-23/

Date: 25/01/23

School: SoET-REV. C-SCHEME Branch: MECH. ENGG. SEM: IV

To,
Exam Controller,
AIKTC, New Panvel.

Dear Sir/Madam,

Received with thanks the following **Semester/Unit Test-I/Unit Test-II (Reg./ATKT)** question papers from your exam cell:

Sr. No.	Subject Name	Subject Code	Format		No. of Copies
			SC	HC	
1	Engineering Mathematics-IV	MEC401		✓	
2	Fluid Mechanics	MEC402		✓	
3	Kinematics of Machinery	MEC403		✓	
4	CAD/CAM	MEC404		✓	
5	Industrial Electronics	MEC405		✓	

Note: SC – Softcopy, HC - Hardcopy

(Shaheen Ansari)
Librarian, AIKTC

30 pm

ME / CE - R-19

Sem-IV - CBCS - C19 - KT

(3 Hours)

[Total Marks: 80]

N.B.: 1) Question No. 1 is Compulsory.

2) Answer any THREE questions from Q.2 to Q.6.

3) Figures to the right indicate full marks.

Q.1 (a) What is the value of $\int_0^{1+i} (x - y + ix^2) dz$ along the line from $z = 0$ to $z = 1 + i$ (5)

(b) Find a and b such that $\vec{F} = (axy + z^3)i + x^2j + bz^2xk$ is irrotational (5)

(c) A random variable X has probability mass function $p(x) = kx^3$; $x=1,2,3,4$ then find the value of k, mean, variance. (5)

(d) Find the probability that at most 4 defective bulbs will be found in a box of 200 bulbs if it is known that 2% of the bulbs are defective. (5)

Q.2 (a) Find the rank correlation coefficient between X and Y; (6)

X	17	13	15	16	6	11	14	9	7	12
Y	36	46	35	24	12	18	27	22	2	8

(b) A random variable has the MGF $M_X(t) = \frac{3}{3-t}$. Find mean and Variance of X. (6)

(c) Obtain Laurent's series expansions of $f(z) = \frac{z-1}{z^2-2z-3}$; $|z| > 3$. (8)

Q.3 (a) A coin is tossed. If it turns up heads two balls are drawn from urn A otherwise two balls are drawn from urn B. Urn A contains 3 black and 5 white balls. Urn B contains 7 black and one white ball. What is the probability that urn A was used, given that both balls drawn are black? (6)

(b) Fit a straight line $y = a + bx$ into the given data. (6)

x:	10	20	30	40	50
y:	22	23	27	28	30

(c) Prove that $\vec{F} = (6xy^2 - 2z^3)i + (6x^2y + 2yz)j + (y^2 - 6z^2x)k$ is irrotational. Find scalar potential of \vec{F} . Hence find the work done of moving particle from (1,0,2) to (0,1,1). (8)

- Q.4** (a) Using Green's Theorem evaluate $\int_c (xy + y^2)dx + x^2dy$ and c is closed curve of the region bounded by $y = x$ and $y = x^2$. (6)
- (b) A machinist is expected to make engine parts with axle diameter of 1.75 cm. A random sample of 10 parts shows a mean diameter of 1.85 cm, with a S.D of 0.1 cm. Based on this sample, would you say that the work of the machinist is inferior? (6)
- (c) A random variable X follows a normal distribution with mean 14 and standard deviation 2.5 find (1) $P[X < 8]$ (2) $P[X > 18]$ (3) $P[12 < X < 15]$ Given: Area between $z=0$ and $z=2.4$ is 0.4918 ; Area between $z=0$ and $z=1.6$ is 0.4452 ; Area between $z=0$ and $z=0.8$ is 0.2882 ; Area between $z=0$ and $z=0.4$ is 0.1554. (8)

- Q.5** (a) The standard deviation from two random samples of sizes 9 and 13 are 1.99 and 1.9. Can the samples be regarded as drawn from normal population with same standard deviation? ($F_{(8,12)}(0.025) = 3.51, F_{(12,8)}(0.025) = 4.20$) (6)
- (b) Use Gauss's Divergence Theorem to evaluate $\iint_S \vec{N} \cdot \vec{F} ds$, where $\vec{F} = 4xi - 2y^2j + z^2k$ and S is region bounded by $x^2 + y^2 = 4, z = 0, z = 4$. (6)
- (c) Obtain both Line of regressions for the data given below
Given $\sum X = 250 ; \sum Y = 300 ; \sum XY = 7900 ; \sum X^2 = 6500 ; \sum Y^2 = 10000$ and $n = 10$ (in usual notation) (8)

- Q.6** (a) Evaluate Value of $\int_C \frac{\sin 2z dz}{(z + \pi/3)^4}$ where $C: |z| = 2$ (6)
- (b) The following data find the correlation coefficient to marks obtained by 11 students in 2 tests, one held at the beginning of the year and the other at the end of the year after intensive coaching: (6)

Test 1	19	23	16	24	17	18	20	18	21	19	20
Test 2	17	24	20	24	20	22	20	20	18	22	19

- (c) A die was thrown 132 times and the following frequencies were observed. (6)

No. obtained	1	2	3	4	5	6	Total
Frequency	15	20	25	15	29	28	132

Test the hypothesis that the die is unbiased at 5% level of significance.

(Given: Table value of χ^2 at 5% level of significance and 5 degree of freedom is 11.07)

12/14/22

Duration: 3hrs

ME - R-19

[Max Marks:80]

Sem-IV - CBCS - C-19 - KT

- N.B. : (1) Question No 1 is Compulsory.
 (2) Attempt any three questions out of the remaining five.
 (3) All questions carry equal marks.
 (4) Assume suitable data, if required and state it clearly.

- 1 Attempt any FOUR [20]
 a Explain Newtonian and non-Newtonian Fluids [5]
 b Explain velocity potential function and stream function. [5]
 c What are the Applications of Bernoulli's equation in Orifice meter, Venturi meter, Rotameter and Pitot tube [5]
 d Define Reynolds number. Explain critical Reynolds number for flat plate and pipe conduit. [5]
 e Explain various Major and Minor losses for flow through pipe [5]
 f Explain Streamlined and bluff bodies
- 2 a The flow field is given by $V = xyi + 2yzj - (yz + z^2)k$ [10]
 i) Show that it represents a possible 3-D steady incompressible continuous flow
 ii) Is this flow rotational or irrotational? If rotational determine at the point (2,4,6)
 a) angular velocity, b) vorticity, c) shear strain, and d) Dilatency
 b Derive an expression for total pressure and centre of pressure for a vertically immersed surface. [10]
- 3 a What is venturimeter? Derive expression of discharge through venturimeter. [10]
 b 360 lit/sec of water is flowing in pipe. The pipe is bent by 120° . The pipe bend measures 360 mm x 240 mm and volume of the bend is 0.14 m^3 . The pressure at the entrance is 73 kN/m^2 and the exit is 2.4m above the entrance. Find the direction and magnitude of resultant force. [10]
- 4 a A liquid of viscosity of 0.9 poise is filled with horizontal plates 10 mm apart. If the upper plate is moving at 1 m/s with respect to the lower plate which is stationary and pressure difference between two sections 60m apart is 60 kN/m^2 . Determine i) The velocity distribution ii) The discharge per unit width iii) The shear stress on upper plate. [10]
 b Derive Euler's equation of motion in rectangular Cartesian co-ordinate system and from this derive Bernoulli's Equation for liquid. State assumptions made in the derivation of Bernoulli's Equation [10]
- 5 a Derive the Hagen-poiseuille Equation. [10]
 b Water is flowing through a pipe having diameter 600 mm and 400 mm at the bottom and upper end respectively. The intensity of pressure at the bottom end is 350 kN/m^2 and the pressure at upper end is 100 kN/m^2 . Determine the difference in datum head if the rate of flow through the pipe is 60 litre/sec. [10]

- 6 a Two reservoirs with a difference in elevation of 15m are connected by the three pipes in series. The pipes are 300 m long of diameter 30 cm, 150 m long of 20cm diameter and 200 m long of 25 cm diameter respectively. The friction factors for three pipes are 0.018, 0.020 and 0.019 respectively and which account for friction and all losses. **Determine** the flow rate in lit/sec. The loss of coefficient for sudden contraction for dia.30 cm to 20 cm is equal to 0.24. [10]

- b Using the laminar boundary velocity distribution: [10]

$$\frac{u}{U} = \frac{3}{2} \left(\frac{y}{\delta} \right) - \frac{1}{2} \left(\frac{y}{\delta} \right)^3$$

- (i) Determine boundary layer thickness in terms of Re
(ii) Check if boundary layer separation occurs

(B) Draw a neat sketch of Tchebicheff mechanism and prove that the length of links must be in a ratio of 1:2:2.5 08

3. (A) Figure shows the mechanism of a radial valve gear. The crank OA turns uniformly at 150 rpm and is pinned at A to rod AB. The point C in the rod is guided in the circular path with D as center and DC as radius. The dimensions of various links are OA = 150 mm; AB = 550 mm; AC = 450 mm; DC = 500 mm; BE = 350 mm. Determine velocity and acceleration of the ram F for the given position of the mechanism. 14

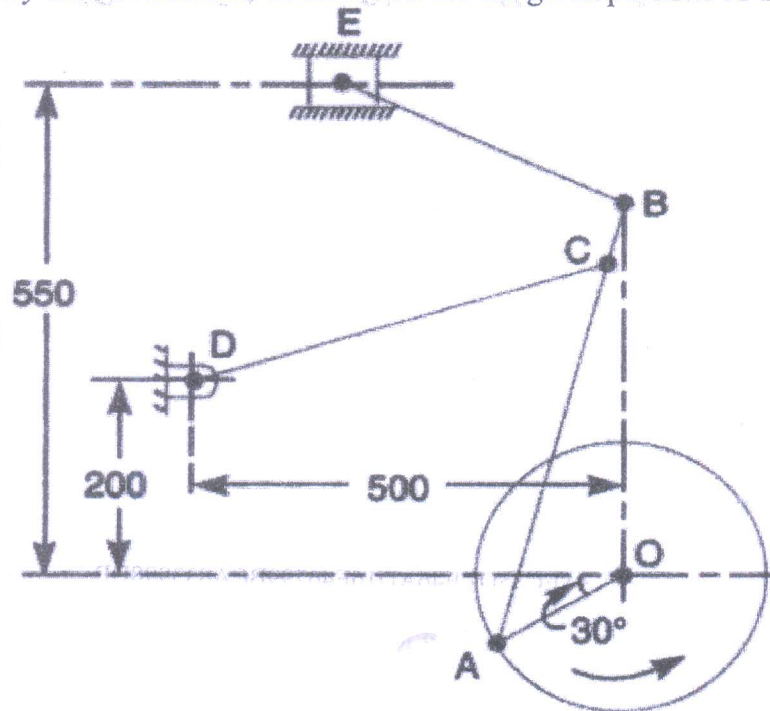

(B) What is the effect of centrifugal tension on power transmitted in belt drive? 06

4. (A) In an open belt drive, the diameters of the larger and smaller pulley are 1.2 m and 0.8 m respectively. The smaller pulley rotates at 320 rpm. The center distance between the shafts is 4 m. When stationary, the initial tension on the belt is 2.8 kN. The mass of belt is 1.8 kg/m and the coefficient of friction between the belt and pulley is 0.25. Determine the power transmitted. 10

(B) A cord wrapped around a solid cylinder of radius 'r' and mass 'm'. The cylinder is released from rest. Determine the velocity of its centre of mass after it has moved down a distance 'h'. 10

5. (A) In a reverted epicyclic gear train, the arm A carries two gears B and C and a compound gear D – E. The gear B meshes with gear E and the gear C meshes with gear D. The number of teeth on gears B, C and D are 75, 30 and 90 respectively. Find the speed and direction of gear C when gear B is fixed, and the arm A makes 100 r.p.m. clockwise 10

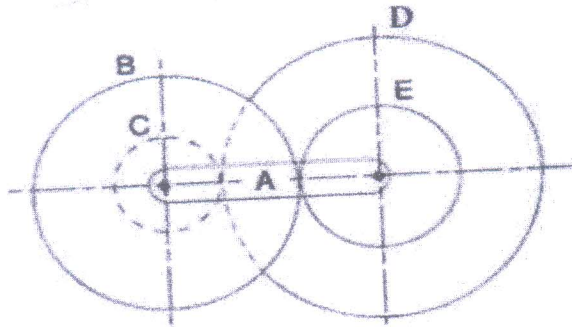

- (B) Compare involute and cycloidal gear teeth profiles 05

- (C) What is chordal action in chain? 05

6. (A) The number of teeth on each of the two equal spur gears in mesh is 50. The teeth have 20° involute profile and the module is 6 mm. If the arc of contact is 1.65 times the circular pitch. Find the addendum. 10

- (B) A cam is rotating at 200 rpm operate a reciprocating roller follower of radius 2.5 cm. The least radius of cam is 30 mm, stroke of follower is 5 cm. Ascent takes place by uniform acceleration and deceleration and descent by simple harmonic motion. Ascent takes place by 70° and descent during 50° of cam rotation. Dwell between ascent and descent 60° . Sketch displacement, velocity, acceleration, and jerk diagram. 10

3:30 pm

Sem-IV - CBCS C19 - KT

ME (R-19)

16/12/22

Duration: 3hrs

[Max Marks:80]

- N.B. : (1) Question No 1 is Compulsory.
(2) Attempt any three questions out of the remaining five.
(3) All questions carry equal marks.
(4) Assume suitable data, if required and state it clearly.

- 1 Attempt any **FOUR** [20]
- a Write short note on scope of Virtual Manufacturing
 - b Explain use of following words in manual part programming
i) N ii) S iii) F iv) T v) X, Y, Z and U, V, W.
 - c Explain translation, scaling, rotation and reflection with suitable examples
 - d Write difference between Wireframe, Solid and surface Modeling
 - e What do you mean by interpolation and approximation curve?
- 2 a Write the difference between Bezier curves, Hermite Curves and B-spline curves with examples. [10]
- b Explain in brief the elements of CNC machine tool system. Write down advantages, limitations and applications of CNC machine tool system. [10]
- 3 a Explain the process of obtaining CAD solid model of body parts using CT output data. [10]
- b Explain in detail Virtual Manufacturing, its socio-economic aspects, and future trends. [10]
- 4 a Explain working principle, application, advantages & disadvantages of Stereolithography Apparatus (SLA) [10]
- b Write classification of RP processes its advantages & disadvantages. Also explain RP applications in design. [10]
- 5 a Write short note on [10]
- i) Homogeneous Coordinate system.
 - ii) Non Contact surface scanning in medical imaging

- b Write a CNC part program using G and M codes for contouring a component of thickness 10mm. Also drill holes of 16mm diameter as shown in figure. Assume cutter speed as 15m/min and feedrate as 0.2 mm/rev. [10]

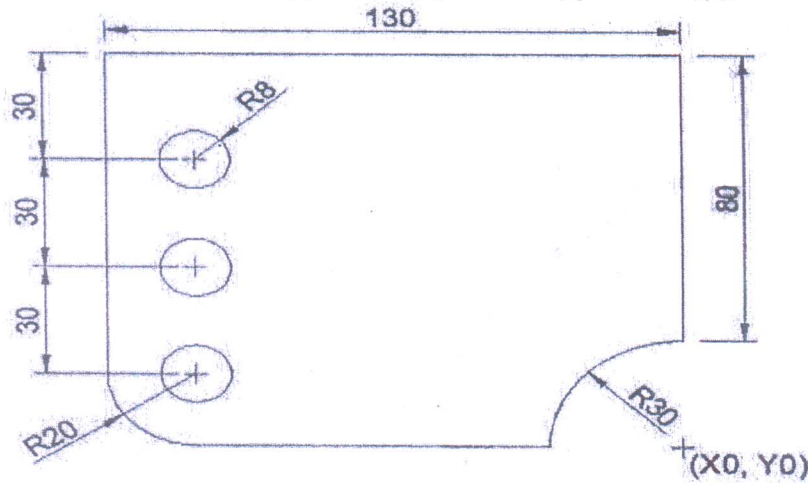

- 6 a Explain the characteristics of the Bezier curve and plot a Bezier curve having control points as $P_0(1, 2)$, $P_1(3, 4)$, $P_2(6, -6)$ and $P_3(10, 8)$. Take a step size of 0.2. [10]
- b A triangle PQR with vertices P (2,5), Q (6,7) and R (2,7) is to be reflected about the line $y=0.5x+3$. Determine (i) the concatenated transformation matrix and (ii) coordinates of the vertices for the reflected triangle. [10]

30 pm

ME (R-19)

Sem-IV - CBCS - CA - KT

(3 Hours)

[Total Marks: 80]

19/12/22

- N.B. : (1) Question No 1 is Compulsory.
(2) Attempt any three questions out of the remaining five.
(3) All questions carry equal marks.
(4) Assume suitable data, if required and state it clearly.

1 Attempt any FOUR

- a Compare between SCR and DIAC
- b Draw and Explain low pass filter
- c What is an operational amplifier? Explain its characteristics
- d Differentiate between microprocessor and microcontroller
- e State and prove De-Morgan's theorems

[20]

2 a. Explain 180 degree mode of operation of inverter

[10]

b. Explain the architecture of MSP 430 microcontroller

[10]

3 a. Draw the circuit diagram of astable multivibrator and explain its operation.

[10]

b. Define and Explain specification parameter of digital logic family.

[10]

4 a. Explain the working principle of single phase bridge inverter circuit.

[10]

b. List various speed control methods of induction motor. Explain voltage control method with a suitable diagram.

[10]

5 a. What is a 555 timer? Write its applications and explain astable multivibrator with associated circuit diagram and waveforms.

[10]

b. Write difference between assembly programming and C programming also write the applications of microcontroller as Speed Measurement using Proximity Sensor.

[10]

6 a. Write a note on a) BLDC Motor b) Servo Motor

[10]

b. Draw and explain the working of multiplexer and de-multiplexer.

[10]