

1913713

Set 02



(2013-14)

ANJUMAN-I-ISLAM'S
KALSEKAR TECHNICAL CAMPUS, NEW PANVEL

School of Engineering & Technology, 2013-2014

Subject: Geotechnical Engineering-I

Date: 08.13

Marks: 30

Duration: 01 Hr

Class: TE (V)

Test - II

Branch: Civil

- Instructions:**
1. Question No. 1 is **COMPULSORY**.
 2. Answer any **TWO** from the remaining.
 3. Each full question carries **EQUAL MARKS**.

1) Discuss the factors affecting the compaction. (10 M)

2) Explain the falling head permeability test. Draw a neat sketch. (10 M)

3) a) A borrow pit's soil is being used as earth fill at a construction project. The in situ dry unit weight of the borrow pit soil was determined to be 17.18 kN/m³. The soil at the construction site is to be compacted to a dry unit weight of 18.90 kN/m³. The construction project requires 15,000m³ of compacted soil fill. Calculate: Volume of soil required to be excavated from the borrow pit to provide the necessary volume of compacted fill. (05 M)

b) Define: i) flow index ii) toughness index (05 M)

4) Following are the results of a liquid limit test: (10 M)

No. of Blows	5	16	23	42
Water Content	31.93	27.62	25.51	23.30

Plastic Limit = 13%, water content = 18%. Calculate: Liquid limit, liquidity index, plasticity index, consistency index, flow index, toughness index. Use semilog graph.

-----END-----



(2013/14)

T E
CIVIL
22-10-13

ANJUMAN-I-ISLAM'S
KALSEKAR TECHNICAL CAMPUS, NEW PANVEL
School of Engineering & Technology

Subject: AH-1
Date: --/10/13
Class: TYCE (SEM V)

Marks: 30
Duration: 1 hr
Branch: Civil Engg.

Test - II

Q1. Attempt any two

10M

- Define unit quantities of turbine.
- Explain working of hydraulic ram with neat sketch.
- Define Reynold's, Froude's, Euler's, Weber's and Mach's number.

Q2.

10M

- Prove that manometric head of a centrifugal pump running at speed N and giving a discharge Q may be written as $H_{man} = AN^2 + BNQ + CQ^2$

OR

- 250 lit/sec of water is flowing in a pipe having a diameter of 300 mm. If the pipe is bent by 135° , find the magnitude and direction of the resultant force on the bend. The pressure of water flowing is 40 N/cm^2 .

Q3.

10M

- The discharge Q over a weir depends on the head of water H , the acceleration due to gravity a , density ρ , the viscosity μ and surface tension σ . Obtain an expression for the discharge using Buckingham's Π theorem.

OR

- A Kaplan turbine develops 24647.6 kW power at an average head of 39 meters. Assuming a speed ratio of 2, flow ratio 0.6, diameter of boss equals to 0.35 times diameter of runner and overall efficiency is 90%. Determine the diameter, speed and specific speed of turbine.



(2013-14)

**ANJUMAN-I-ISLAM'S
KALSEKAR TECHNICAL CAMPUS, NEW PANVEL
School of Engineering & Technology**

Subject: AH-1
Date: --/10/13
Class: TYCE (SEM V)

Marks: 30
Duration: 1 hr
Branch: Civil Engg.

Test - II

Q1. Attempt any two

10M

- (a) Define unit quantities of turbine.
- (b) Explain working of hydraulic ram with neat sketch.
- (c) Define Reynold's, Froude's, Euler's, Weber's and Mach's number.

Q2.

10M

- (a) Prove that manometric head of a centrifugal pump running at speed N and giving a discharge Q may be written as $H_{\text{man}} = AN^2 + BNQ + CQ^2$

OR

- (b) 250 lit/sec of water is flowing in a pipe having a diameter of 300 mm. If the pipe is bent by 135° , find the magnitude and direction of the resultant force on the bend. The pressure of water flowing is 40 N/cm^2 .

Q3.

10M

- (a) The discharge Q over a weir depends on the head of water H , the acceleration due to gravity a , density ρ , the viscosity μ and surface tension σ . Obtain an expression for the discharge using Buckingham's Π theorem.

OR

- (b) A Kaplan turbine develops 24647.6 kW power at an average head of 39 meters. Assuming a speed ratio of 2, flow ratio 0.6, diameter of boss equals to 0.35 times diameter of runner and overall efficiency is 90%. Determine the diameter, speed and specific speed of turbine.



(2013-14)

ANJUMAN-I-ISLAM'S
KALSEKAR TECHNICAL CAMPUS, NEW PANVEL
School of Engineering & Technology

Subject: BDD-II

Marks: 40

Class: TE (✓)

Test: II

Date: 08/13

Duration: 02Hr/s

Branch: Civil

Instructions:

- 1) Question No. **1** is **Compulsory**.
- 2) Attempt any **One** question out of remaining **Two** Questions.
- 3) Assume any data if **required** & state them **clearly**.

Q.1. a) It is proposed to construct a bank bld. in urban area. The building is (G+1) RCC framed structure. The plot area is 40 m x 50 m with FSI = 0.5

- I) Draw Ground floor plan (15)
- II) Draw the line plan of first floor. (05)

Q.2. Draw the two point perspective view of bld. you have planned in **Q.1.** (20)

Q.3. Write short notes on: (20)

- a) Green Buildings. 2) Green Belt. 3) Slum clearance 4) Town Planning

DSSHAH



(2013-14)

ANJUMAN-I-ISLAM'S
KALSEKAR TECHNICAL CAMPUS, NEW PANVEL

School of Engineering & Technology, 2013-2014

Subject: Structural Analysis-II

Date: Oct 13

Marks: 30

Duration: 01 Hr

Class: TE

Branch: Civil

Test - II

- Instructions:
1. Question No. 1 is **COMPULSORY**.
 2. Answer any **TWO** from the remaining.
 3. Each full question carries **EQUAL MARKS**.

- 1) Analyze continuous beam of fig. 1 by stiffness matrix method. Draw SFD & BMD. (10 M)
- 2) Analyze the frame (fig. 2) by moment distribution method. Draw BMD. (10 M)
- 3) Analyze the frame of fig. 3. Draw SFD & BMD. Use slope-deflection method. (10 M)
- 4) A) Analyze the continuous beam of fig. 4 by stiffness matrix method. (05 M)
B) Analyze the continuous beam of fig. 5. Use slope-deflection method. (05 M)

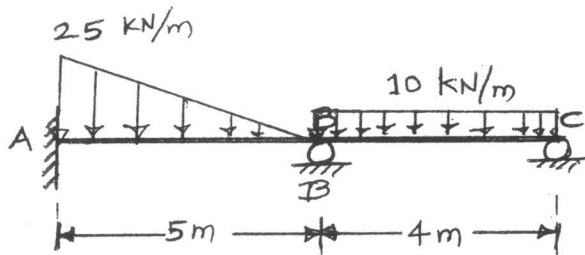

FIG.1

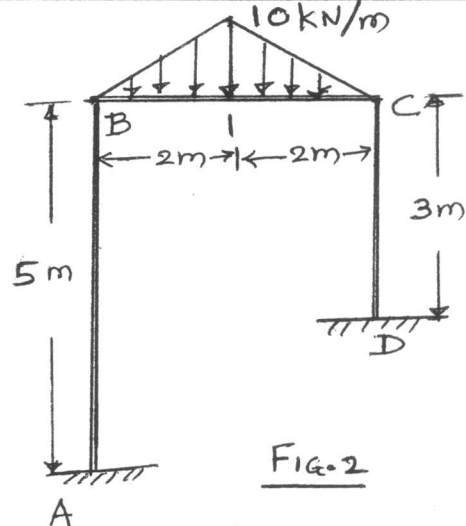
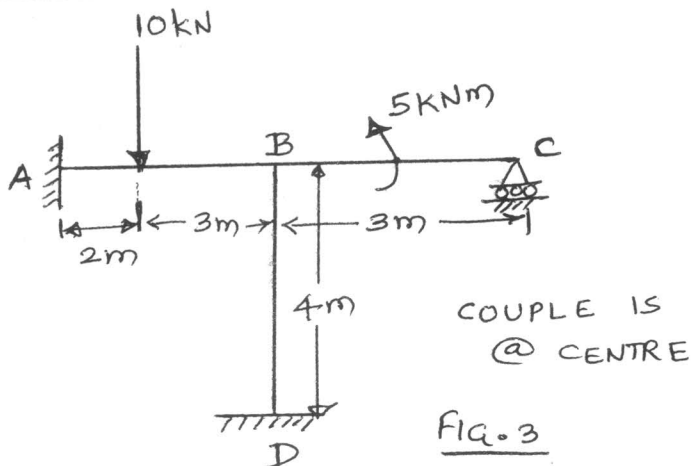
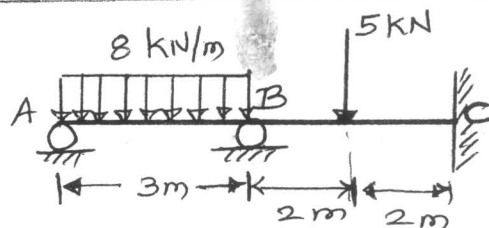

FIG.2



COUPLE IS
@ CENTRE

FIG.3



Only End mom. FIG.4

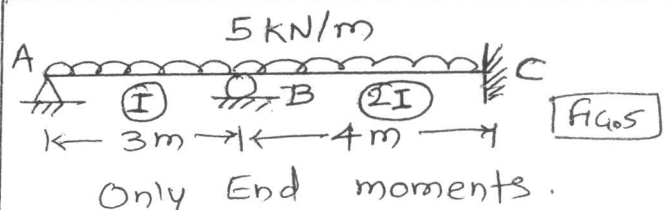

Only End moments. FIG.5



(2013-14)

ANJUMAN-I-ISLAM'S
KALSEKAR TECHNICAL CAMPUS, NEW PANVEL
School of Engineering & Technology

Subject: Geotechnical Engineering-I

Marks: 30

Class: Third Year (V)

Date: 06/09/2013

Duration : 1 Hr/s

Branch: Civil Engineering

Test-II

- Instructions: 1. Question No. 1 is compulsory.
2. Solve any two out of remaining three.

Q.1 Solve any two

(10 M)

- Mention the scope of geotechnical engineering in the design of structures.
- Derive the following relationship

$$e = \frac{G\gamma_w}{\gamma_d} - 1 \text{ with usual notations.}$$

- Derive the relationship between e, w, G, S_r .
- Explain consistency.

Q.2 A soil has bulk unit weight of 20.1 KN/m^3 and water content of 15%. Calculate the water content if the soil partially dries to a density of 19.4 KN/m^3 and the void ratio remains unchanged. (10 M)

Q.3 A natural soil deposit has a bulk unit weight of 18.44 KN/m^3 and water content of 5%. Calculate the amount of water required to be added to 1 m^3 of soil to raise the water content to 15%. Assume the void ratio to remain constant; what will then be the degree of saturation? Assume $G=2.67$. (10 M)

Q.4 Soil, 2000 m^3 in volume is excavated from a borrow pit where the natural water content is 15% and the unit weight is 17 KN/m^3 . The soil is used in an embankment compacted at porosity of 30%. What will be the volume of compacted embankment assuming no change in dry mass and moisture content of soil? Take G as 2.68. Find also the degree of and air content of the borrow pit and embankment. (10 M)



(2013-14)

ANJUMAN-I-ISLAM'S
KALSEKAR TECHNICAL CAMPUS, NEW PANVEL
School of Engineering & Technology

Subject: Transportation Engg.- I Marks: 30
Date: /09/2013 Duration: 1 hr
Class: TYCE (SEM - V) Branch: Civil Engg.

Test - II

Note: Question No-01 is compulsory. Solve any three Questions from the Q No-02

- Q.1 a) What is crossing? Enlist the types of crossing. (03)
 b) Give the classification of Signals. (03)
 c) Enlist the types of yards and explain the working of Marshalling Yard. (03)
- Q.2 a) What are the Functions of FAA? (07)
 b) What are the Objectives of Signalling? Explain operational principal of Semaphore signal with sketch (07)
 c) Enlist Different Aircraft characteristics also draw figure showing all component parts of Aircraft. (07)
 d) Explain three control system for the stabilization of aircraft (07)



Symbol of Secularism
& National Integration

ANJUMAN-I-ISLAM'S
KALSEKAR TECHNICAL CAMPUS, NEW PANVEL
School of Engineering & Technology

(2013-14)

Subject: Entrepreneurship & Management

Marks: 30

Date: 23/10/2013

Duration: 1 hr

Class : TYCE(SEM V)

Class Test - II

Branch : Civil

UNIT TEST: 2

- N.B. (1) Q No. 1 is Compulsory
(2) Attempt any two questions from Q No. 2 to 4

1. Define present value and future value of a single amount [10]
 - (i) If you deposit Rs. 1,00,000/- today in a contractor's firm from which you expect a profit of 13% annually, how much will the deposit give after 8 years and 12 years?
 - (ii) If you expect to receive Rs 1,00,000/- annually for 3 years, each receipt occurring at the end of the year; what is present value of the stream of benefits if the discount rate is 10%?
2. Answer in brief [5 * 2]
 - (a) Enlist Henry Fayol's principles of management. Explain any 2 in detail.
 - (b) Explain the concept of Balance Sheet with an example.
3. Write short notes on: [5*2]
 - (a) Functions of Management
 - (b) ISO Certification and its importance.
4. Write short notes on: [5*2]
 - (a) Time Value of Money
 - (b) Project Life Cycle